

## BENEFITS

- High performance 25 Gbaud Gen-4/5 backplanes compatible with 100 Gb Ethernet (100GBASE-KR4) and PCI Express® (PCIe) Gen-4 (16 Gbaud) on OpenVPX data plane and expansion plane fabrics
- Operate on high performance VITA 46.30 Multigig RT-3 connector. Contact factory for alternate connectors such as R-VPX EVO2.
- Multiple backplane profiles available, including pass-thru backplanes
- 3U and 6U with varied slot counts
- Fit in Atrenne lab development chassis and ready for deployment in rugged applications.



# GEN-3 OpenVPX Backplanes

This product family is part of the industry-leading Atrenne's product line of high performance chassis and backplanes.

## OVERVIEW

Atrenne, a Celestica company, offers a wide range of high performance backplanes, with 6U, 3U and hybrid 3U/6U models available. Our Gen-3 OpenVPX backplanes are part of an innovative product family that makes up the industry's first end-to-end solution for 40 Gigabit systems.

Designed to the demanding signal integrity requirements of the VITA 68 VPX™ compliance channel draft standard, these high performance Gen-3 backplanes offer the highest signal integrity in the industry and are typically used in air-cooled or conduction-cooled development chassis. Atrenne can also design application-specific configurations to meet your individual requirements.

## FEATURES

- VITA 65 OpenVPX™ compliant backplanes
- VITA 46/VITA 48 VPX REDI™-compliant
- VITA 46.10 RTM connectors
- Multiple backplane profiles available, including backplanes with routed fabric connections, as well as both 3U and 6U pass-thru backplane versions which can be used with high speed RTM cables
- Provisions for mechanical stops to prevent misinsertion of payload cards
- Stiffeners placed every other slot to ensure backplane rigidity
- Designed to stringent Atrenne Gen-3 signal integrity design rules; signal integrity-compliant above and beyond VITA 68, up to 10.3 Gbaud with extremely low insertion loss. Innovative signal integrity methods used to minimize return loss, crosstalk, and mode conversion (patent pending).
- Optional rear transition connectors
- Optional conformal coating
- Keying and alignment per VITA 65 and VITA 46
- Durability: mate-unmate for 200 cycles
- Non-Volatile Memory Read Only (NVMRO) signal (jumper selectable)
- Optional battery backup input, jumperable to +3.3V
- SYSCON selectable - set to 1st VPX slot as default

Contact factory for RF feed-thru backplanes per VITA 67.x or fiber optic feed-thru backplanes per VITA 66.x

Contact factory for alternate connectors such as RT2-R

## TABLE 1: TECHNOLOGY OVERVIEW

PHYSICAL		ENVIRONMENTAL	
3U Height	5.067"	ANSI/VITA 47 Class EAC6	
6U Height	10.317" (except 6U 16-slot backplane, which is 11.3" H)	Flammability Rating	UL94-V0
Backplane Material	High performance low loss laminate with multi-level backdrill	Temperature Ranges	Operating: -40 to +85°C Storage: -55 to +100°C
STANDARDS COMPLIANCE		SAFETY	
VITA 68	ANSI/VITA 46.0-2007 (R2013)	Regulatory	Designed to meet UL, CSA and CE requirements
ANSI/VITA 65-2010 (R2012)	ANSI/VITA 46.10-2009	Power Rails Current Carrying	All backplanes meet VITA 65 OpenVPX recommended current levels
ANSI/VITA 46.3-2012	ANSI/VITA 48.0-2010		
ANSI/VITA 46.4-2012	ANSI/VITA 48.1-2010		
ANSI/VITA 46.6-2012	ANSI/VITA 48.2-2010		
ANSI/VITA 46.7-2012	-VITA 46.8 VDSTU		

## TABLE 2: STANDARD VPX BACKPLANE PART NUMBER MATRIX

PART NUMBER	BACKPLANE DESCRIPTION	BACKPLANE PROFILE	PAYLOAD SLOT PROFILE	PAYLOAD MODULE PROFILE	SWITCH SLOT PROFILE	SWITCH MODULE PROFILE
024-901-06-X1G3-01	3U, VPX REDI 1" pitch (7 slots wide), no data plane, control plane, or expansion plane fabric connectivity, all fabric signals pass through to RTM connectors for users, 10.3 Gbaud optimized	N/A Open for user to implement connectivity using cables.	All	All	All	All
024-901-06-C2G3-01	3U, 6-slot VPX REDI 1" pitch (7 slots wide), 5 payload slots, 1 data and control switch slot, star fabric topology, no expansion plane, 10.3 Gbaud	BKP3-CEN06-15.2.18-4	SLT3-PAY-1F2F2U-14.2.2	MOD3-PAY-1F2F2U-16.2.2-(all)	SLT3-SWH-6F6U-14.4.1	MOD3-SWH-6F6U-16.4.1-(all)
024-901-09-X1G3-01	3U, 9-slot VPX REDI 1" pitch wide, no data plane, control plane, or expansion plane fabric connectivity, all fabric signals pass through to RTM connectors for users, 10.3 Gbaud optimized	N/A Open for user to implement connectivity using cables	All	All	All	All
024-900-06-C2G3-01	6U, 6-slot VPX REDI 1" pitch (7 slots wide), 5 payload slots, 1 data and control switch slot, star fabric topology, expansion plane, 10.3 Gbaud	BKP6-CEN06-11.2.25-4	SLT6-PAY-4F1Q2U2T-10.2.1	MOD6-PAY-4F1Q2U2T-12.2.1-(all)	SLT6-SWH-16U20F-10.4.2	MOD6-SWH-16U20F-12.4.2-(1-13,15)
024-900-06-X1G3-01	6U, 6-slot VPX REDI 1" pitch (7 slots wide), no data plane, control plane, or expansion plane fabric connectivity, all fabric signals pass through to RTM connectors for users, 10.3 Gbaud	N/A Open for user to implement connectivity using cables	All	All	All	All
024-900-16-X1G3-01	6U, 16-slot VPX REDI 1" pitch (16 slots wide), no data plane, control plane, or expansion plane fabric connectivity, all fabric signals pass through to RTM connectors for users, 10.3 Gbaud optimized	N/A Open for user to implement connectivity using cables	All	All	All	All
024-900-16-C1G3-01	6U, 16-slot VPX REDI 1" pitch (16 slots wide), 14 payload slots, 2 data & control switch slots, dual star fabric topology, expansion plane, 10.3 Gbaud	BKP6-CEN16-11.2.2-4	SLT6-PAY-4F1Q2U2T-10.2.1	MOD6-PAY-4F1Q2U2T-12.2.1-(all)	SLT6-SWH-20U19F-10.4.1	MOD6-SWH-20U19F-2.4.1-(1-13,15)
024-900-06-C3G3-01	6U, 6-slot VPX REDI 1" pitch (7 slots wide), 5 payload slots, 1 data and control switch slot, star fabric topology, no expansion plane, 10.3 Gbaud	BKP6-CEN06-11.2.23-4	SLT6-PAY4F1Q2U2T-10.2.1	MOD6-PAY-4F1Q2U2T-12.2.1-(all)	SLT6-SWH-16U20F-10.4.2	MOD6-SWH-16U20F-12.4.2-(1-13,15)
024-900-16-C2G3-01	6U, 16-slot VPX REDI 1" pitch (16 slots wide), 8 payload slots, 2 data & control switch slots, 6 pass-thru slots, dual star fabric topology, no expansion plane, 10.3 Gbaud	BKP6-CEN16-11.2.24-4	SLT6-PAY4F1Q2U2T-10.2.1	MOD6-PAY-4F1Q2U2T-12.2.1-(all)	SLT6-SWH-16U20F-10.4.2	MOD6-SWH-16U20F-12.4.2-(1-13,15)

Figure 1: 024-900-16-C1G3-01

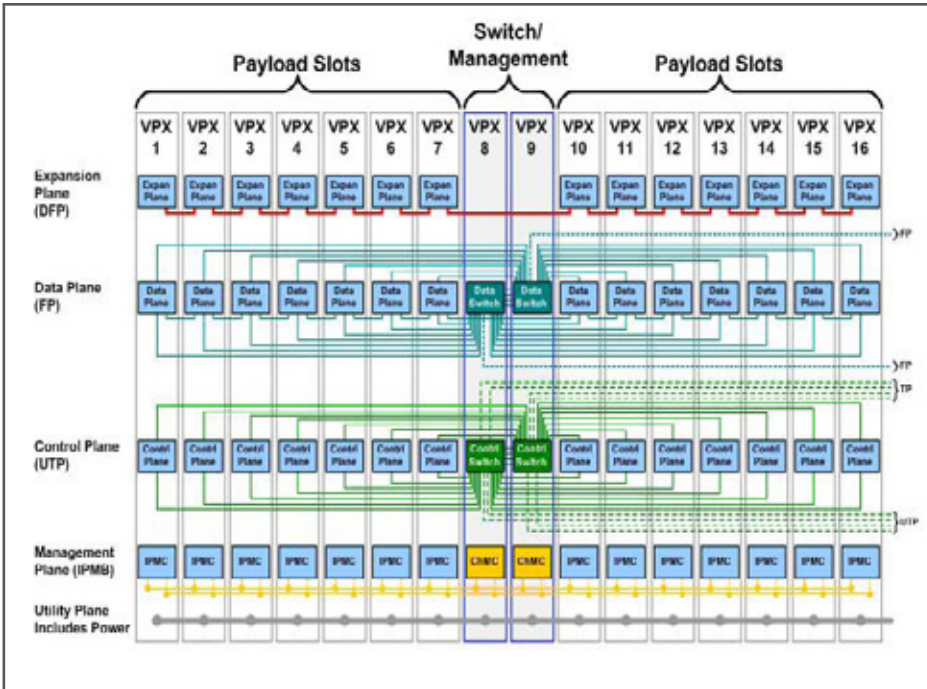

Note that this topology is identical to 024-900-16-CEN1-01; the only difference is that this backplane is rated to 10.3 Gbaud.

Figure 2: 024-900-06-C2G3-01

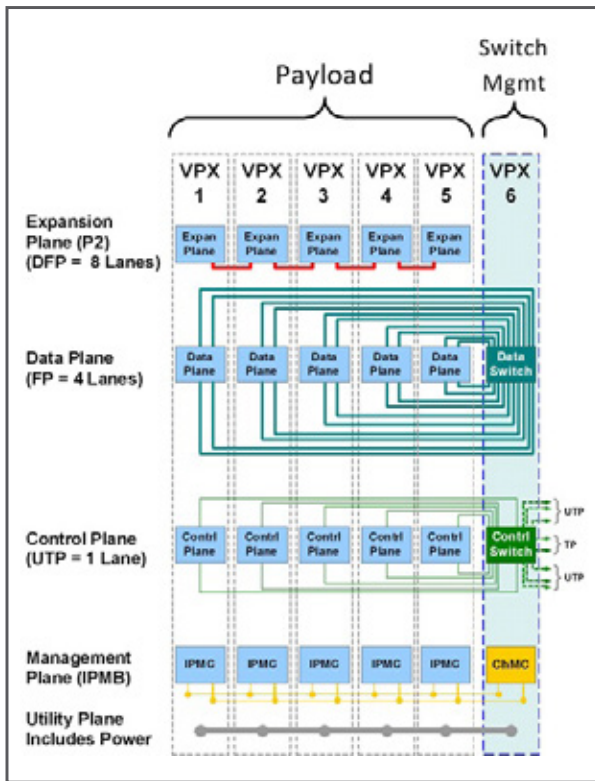

Note that this topology is a new profile that is proposed for the next revision of VITA 65.

Figure 3: 024-900-06-C3G3-01

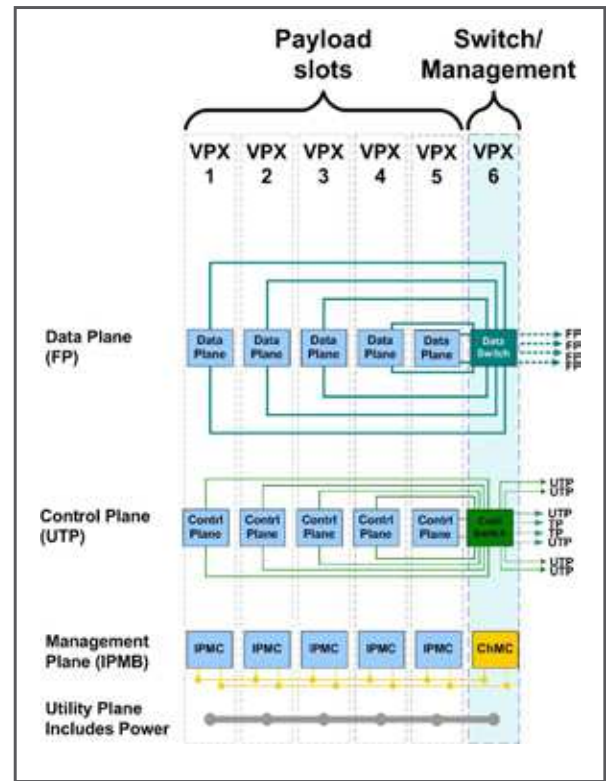

Note that this topology is a new profile that is proposed for the next revision of VITA 65.

Figure 4: 024-900-16-X1G3-01

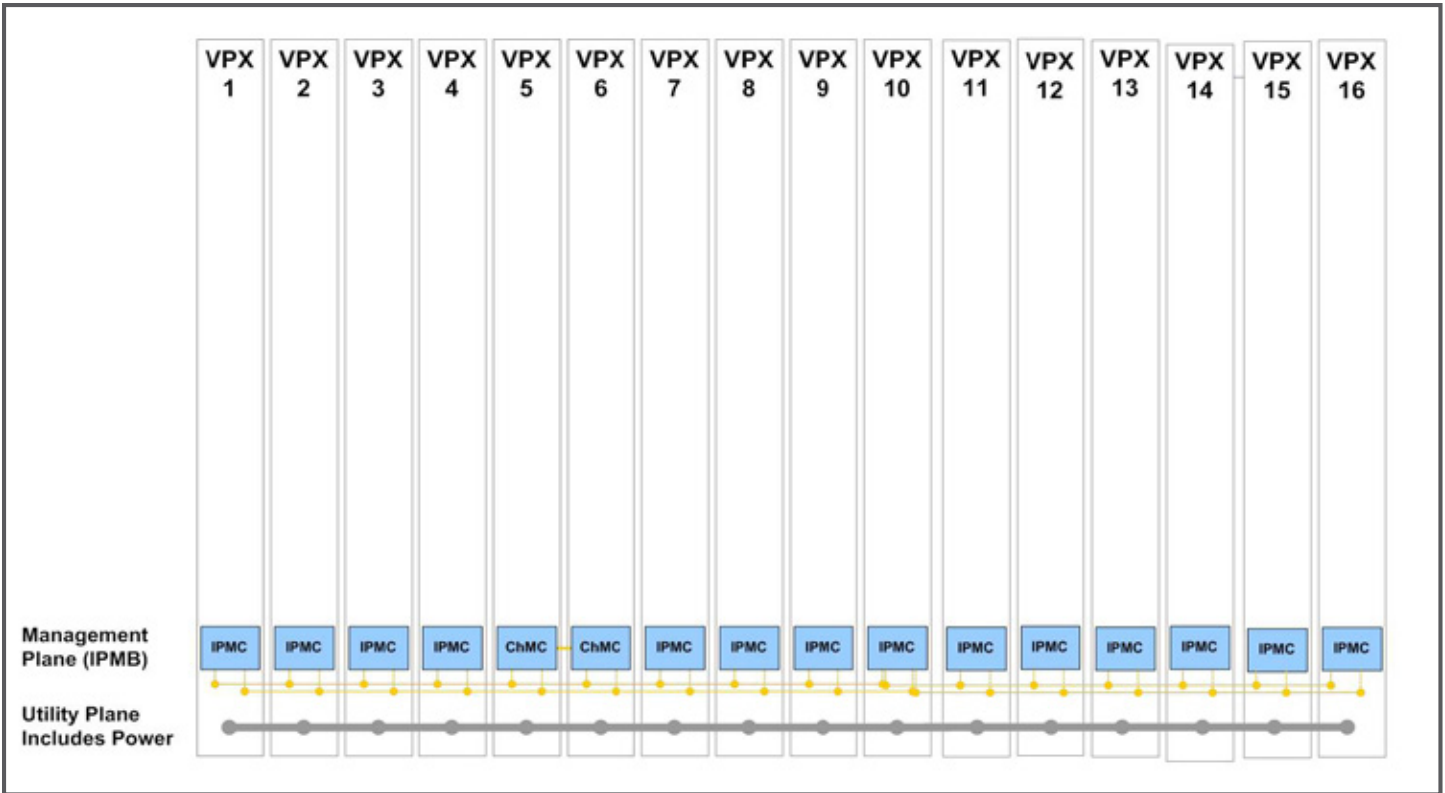
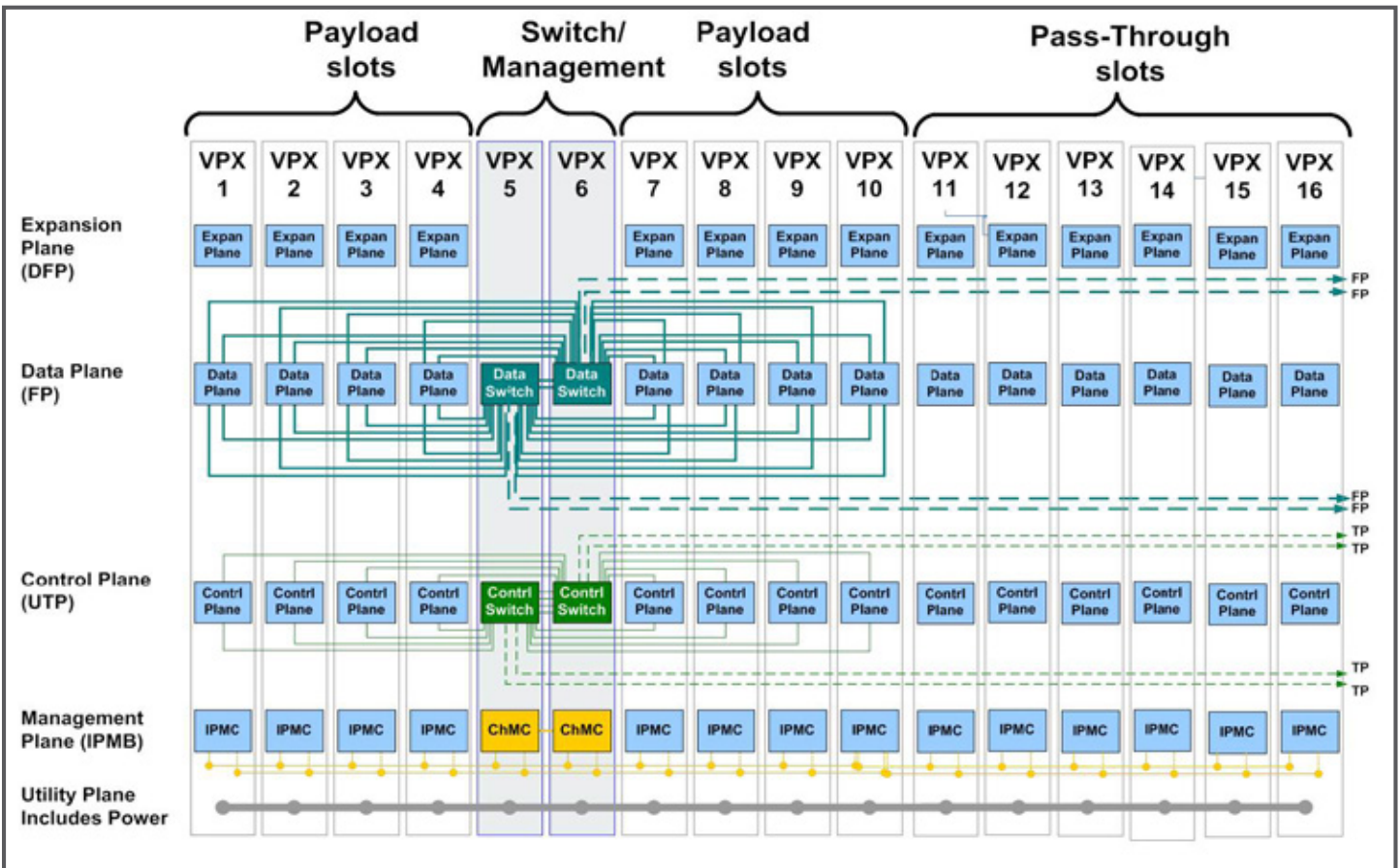

Figure 5: 024-900-16-C2G3-01



Note that this topology is a new profile that is proposed for the next revision of VITA 65.

Figure 6: 024-900-06-X1G3-01

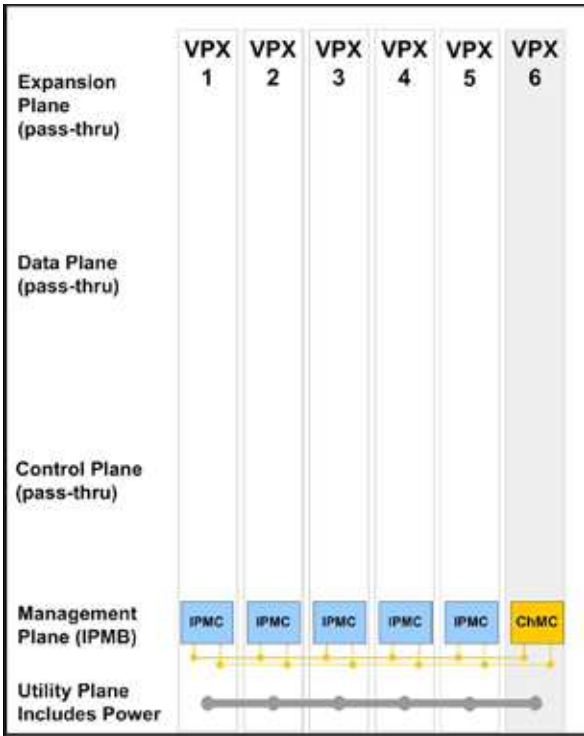
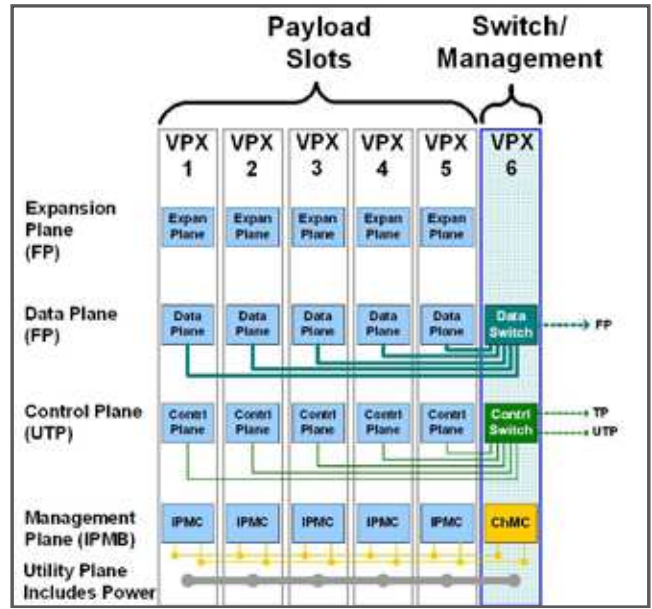

Figure 7: 024-901-06-C2G3-01



Note that this topology is a new profile that is proposed for the next revision of VITA 65.

Figure 8: 024-901-06-X1G3-01

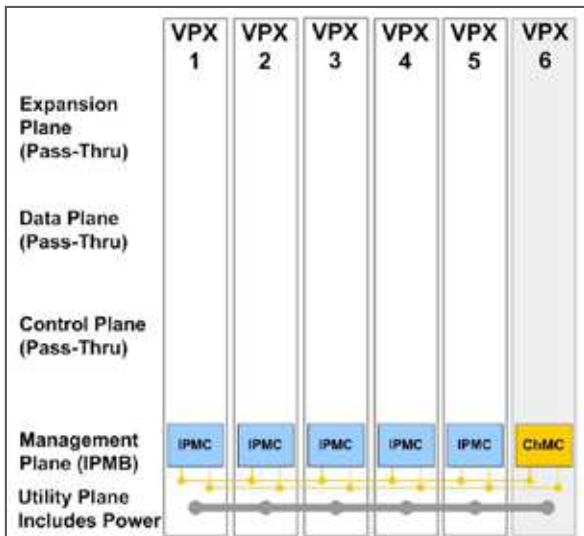
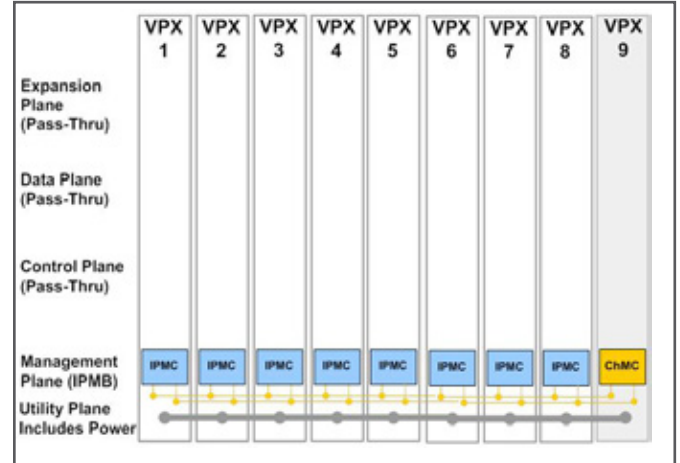

Figure 9: 024-901-09-X1G3-01



**WARRANTY**

This product has a one year warranty.

**CONTACT INFORMATION**

www.atrenne.com  
 sales@atrenne-cs.com  
 508.588.6110

The information in this document is subject to change without notice and should not be construed as a commitment by Atrenne, a Celestica company. While reasonable precautions have been taken, Atrenne assumes no responsibility for any errors that may appear in this document. All products shown or mentioned are trademarks or registered trademarks of their respective owners.