

## Rugged 3U VPX™ Storage Board with Front Removable Bays

### Key Features

TR MS7/600 is a rugged 3U VPX™ storage board that is capable of high capacity within a single 1-inch slot pitch. It has two front removable storage bays enabling data mobility at the edge with write protection and security features.



- 3U VPX Storage Module
- Two front removable conduction-cooled NVMe™ Solid State Drives
- 480GB to 7.7TB Capacity
- AES 256-bit encryption
- Optional data destruction capability
- Rugged conduction-cooled

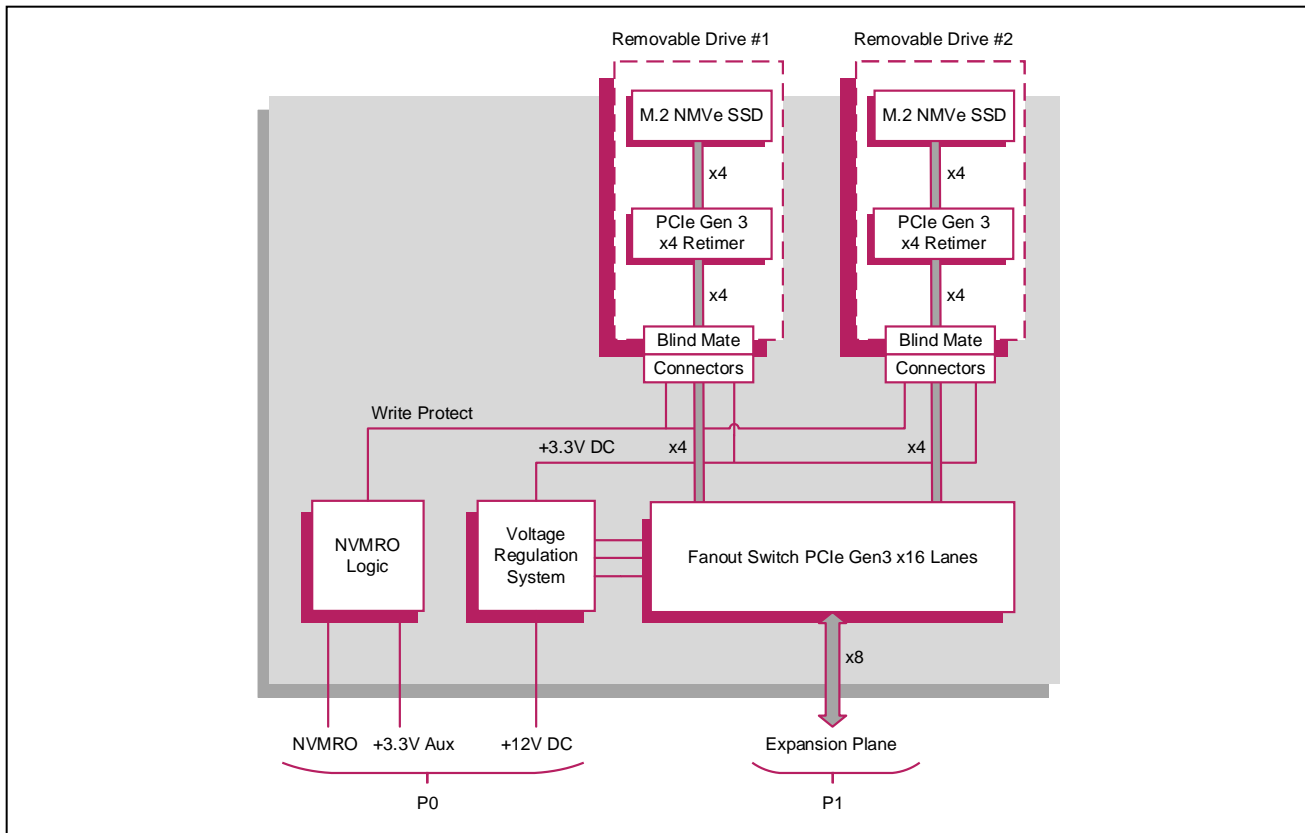

## VPX Storage Card

- Rugged 3U VPX™ Storage Card supports two front removable rugged storage bays
- Compatible with OpenVPX™ slot profile
  - SLT3p-PAY-1F1U1S1S1U1U2F1H-14.6.11-n
- Data Plane: N/A
- Expansion Plane: PCIe Gen 3 x8 (EP00-EP07)
- Control Plane: N/A
- total capacity 480GB to 7.7TB
- conduction-cooled to VITA 48.2
- conformally coated

## Docking Bay

- connects to Expansion Plane via P1
- incorporates a 16 lane PCIe Gen 3 Fanout Switch
- each bay has a channel speed of 4GB/s

## Removable Storage Bays

- two removable storage drives
- conduction-cooled
- each NVMe™ drive connected to the host by PCIe Gen 3 x4 interface
- front removable drives available in capacities of 480, 960 GB, 1.92 and 3.84 TB each
- maximum total capacity of 7.7TB
- the actual data rates (Read and Write) is determined by the drives installed
- industrial temperature drives (-40 to +85°C):
  - Read: 2,500 to 3,000 MB/s
  - Write: 340 to 1,000 MB/s
- blind mate connectors between the docking bay and the removable SSD bays guaranteed for 1,000 insertion/removal cycles

## Data Destruction Options

- determined by removable SSDs installed
- implemented via NVMe command

## Safety

- PCB (PWB) manufactured with flammability rating of UL94V-0

## Electrical Specification (Estimated)

- typical:
  - +12V VS1 @ 1.83A
- +3.3V AUX & TBD
- +12V AUX and -12V AUX not connected
- +5V and +3.3V are not connected

## Environmental Specification

- operating temperature (at card edge):
  - VITA 47.1 Class CC4, -40°C to +85°C
  - Conduction-cooled (VITA48.2)
- non-operating temperature:
  - VITA 47.1 Class C4, -55°C to +105°C
- operating altitude:
  - -1,500 to 60,000 feet (-460 to 18,300 meters)
- relative humidity: 5% to 95%, non-condensing

## Mechanical Specification

- 3U VPX form-factor (VITA 46.0, VITA 48.0)
- 3.9 inches x 6.3 inches (100mm x 160mm)
- slot width (VITA 48.0)
  - 1.00 inch
- connectors to VITA 46.0 for P0 and P1
- operating mechanical:
  - shock - VITA 47.1 Class OS2, 40g, 11ms
  - random vibration – VITA47.1 Class V3 0.1g<sup>2</sup>/Hz

## Related Products

- Compatible 3U VPX boards include TR H4x/3sd-RCx Server Board and TR J4x/6sd-RCx Optical Server Board. 3U VPX Development systems are also available. Contact Concurrent Technologies for more details.