

# DRF3182

Direct RF 3U VPX board with  
Intel® Stratix® 10 AX-Series SoC FPGA



DRF3182

The DRF3182 3U OpenVPX board is an ultra-high-speed data conversion and FPGA processing solution ideal for directly digitizing high-frequency signals in radar, communications, and electronic warfare systems. New electronic warfare systems must respond to signals that use spread spectrum or frequency hopping modulation techniques that require a wide acquisition bandwidth (IBW) to properly detect, respond and classify them. The integrated data capture capability, combined with powerful processing from Intel's 14 nm Intel Stratix 10 FPGA, make it uniquely suited for these low-latency, wideband, SWaP-constrained, high-performance applications.

## FAQ

### What is the benefit of direct RF?

Direct RF technology removes the need to implement RF to IF up and down conversion prior to digitization. This eliminates equipment and complexity from solutions reducing size, weight, power and cost. The advanced data converters in the DRF3182 provide frequency agility to enable systems to rapidly respond to an ever-changing spectral environment.

### What types of applications would the DRF3182 best serve?

The DRF3182's flexible compute environment, high-bandwidth interfaces and frequency agility make it an excellent device for electronic warfare, ELINT, radar, test/measurement applications and other high-performance applications with SWaP constraints. In addition, a ultra-high IBW makes it uniquely suited for radar beamforming, reconnaissance and next-generation EW solutions.

### What are the SWaP benefits for this product?

The direct RF capabilities of the DRF3182 remove the requirement for RF to IF conversion in the 2-18 GHz frequency range. This eliminates separate up/downconverter hardware found in most electronic warfare and radar systems. Furthermore, RFSoc's, with their on-chip data converters and ultra-short-reach interfaces, require less power, take up less space and provide lower latency when compared to solutions employing discrete data converter designs.

### What interfaces does the DRF3182 include?

The DRF3182 includes 4 Rx and 4 Tx RF interfaces on the front panel of the module and six data plane fat pipes to P1 and P2 providing an impressive 600 Gbps of backplane ingress/egress bandwidth in a small 3U form factor.

### What kind of supporting firmware or software is included?

The DRF3182 is built with an EchoCore® FPGA IP to provide basic infrastructure functionality right out of the box. EchoCore simplifies application integration by providing a standard control plane interface using AvalonMM control plane connectivity and a simple

AvalonStream interface for data plane interfaces. Customers may choose their own tool to generate signal processing algorithms, such as vendor-specific IPs, HLS or RTL. The cores are then instantiated into a reserved user block and compiled into the FPGAs.

## EXAMPLE RECEIVE APPLICATION ARCHITECTURE

### DIRECT RF SAMPLING ARCHITECTURE

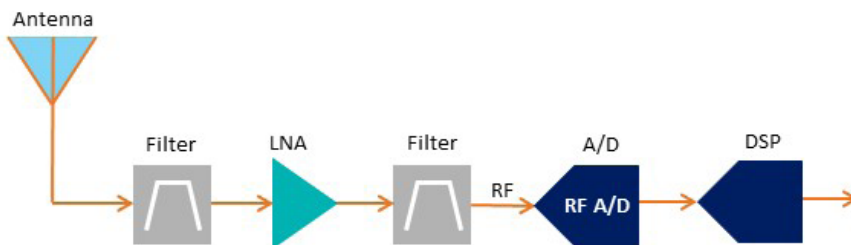

Direct RF at the edge eliminates the need for IF analog components, which increases performance, decreases system-level costs, and reduces SWaP.

### IF SAMPLING ARCHITECTURE

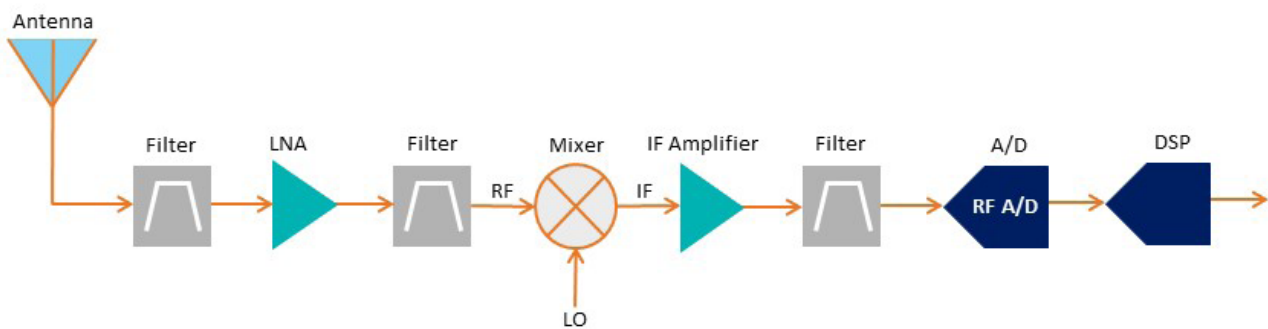

Learn more  
Visit: [mrcy.com/DRF3182](http://mrcy.com/DRF3182)



The Mercury Systems logo and the following are trademarks or registered trademarks of Mercury Systems, Inc.: Mercury Systems and Innovation That Matters. Other marks used herein may be trademarks or registered trademarks of their respective holders. Mercury believes this information is accurate as of its publication date and is not responsible for any inadvertent errors. The information contained herein is subject to change without notice.  
© 2022 Mercury Systems, Inc. | 8200.00E-0123-faq-DRF3182