

V1160

Dual-Port 100G Rugged Ethernet XMC Card



Benefits

High-performance rugged Ethernet XMC card built for sensor interface, data distribution, storage, security, and communications

Turns a single board computer into a single slot sensor processor
Embedded focus with VITA 20 and VITA 47 compliance

Versatile design supports electrical or optical Ethernet interfaces, optical options for both backplane or front-panel VPX support

COTS solution optimized for system SWaP (size, weight and power)
Modular optics for flexibility in supporting 10-25Gbps per lane

Rx/Tx optical transceivers with standard flyover fiber cables to front panel MPO connector or backplane MT connector

Options for 3U VPX, 6U VPX, and PXIe form factor via carrier cards

Features

Dual 10/25/40/50/100Gbps Ethernet ports

Rugged optical ports via MPO (female) on the front panel or VITA 66 optical backplane. Electrical I/O via Pn6 also available

NVIDIA® Mellanox® ConnectX®-5 Network Interface

Device Hardware offloads for UDP, TCP, RoCE v2, DPDK, +more

Supports PCIe Gen4 x16, Gen4 x8, Gen3 x16, Gen3 x8

On board embedded PCIe Switch device

Advanced APIs that support multi-core and multi-processor architectures

Wide range of operating system software support

Available in air- and conduction-cooled XMC form factors

Conformal coating and carrier card options available

Overview

The V1160 is designed for high-bandwidth and low-latency interface applications requiring 10/25/40/50/100Gbps Ethernet. Targeted towards radar, signal intelligence, video, storage, medical imaging, and embedded communications systems, the convenient XMC form factor and rugged design of the V1160 turns a VPX-based single board computer into a single-slot sensor processor.

Featuring the NVIDIA® Mellanox® ConnectX®-5 network interface device, the V1160 is the proven performance leader in Ethernet applications. With hardware offloads for UDP, TCP, RoCE v2, DPDK, and many other protocol offloads, payload data throughput and latency is unmatched in the V1160. Visit NVIDIA® Mellanox® ConnectX®-5 Datasheet1 for further information.

Options are provided to select optical or electrical Ethernet interfaces, as well as for front panel IO or backplane IO. Backplane electrical interfaces are provided via Pn6 and backplane optical interfaces are provided via VITA 66 connectors.

The V1160 is built from the ground up for rugged and harsh environments. Component selection, thermal design, and electrical design have all been done with the requirements of high performance embedded computing at the forefront. This XMC is designed and tested to VITA 47 environmental standards and provides VITA 20-compliant conduction cooling. Supporting temperature ranges from -40°C to +85°C, each V1160 XMC card delivers a reliable, long-lasting solution for your rugged embedded needs.

The V1160 is the industry’s most advanced Ethernet XMC solution. The V1160 is designed to provide a real time high-bandwidth network interface for next generation sensor, storage, and communication systems in a rugged and SWAP-C-centric package.



V1160

Dual-Port 100G Rugged Ethernet XMC Card

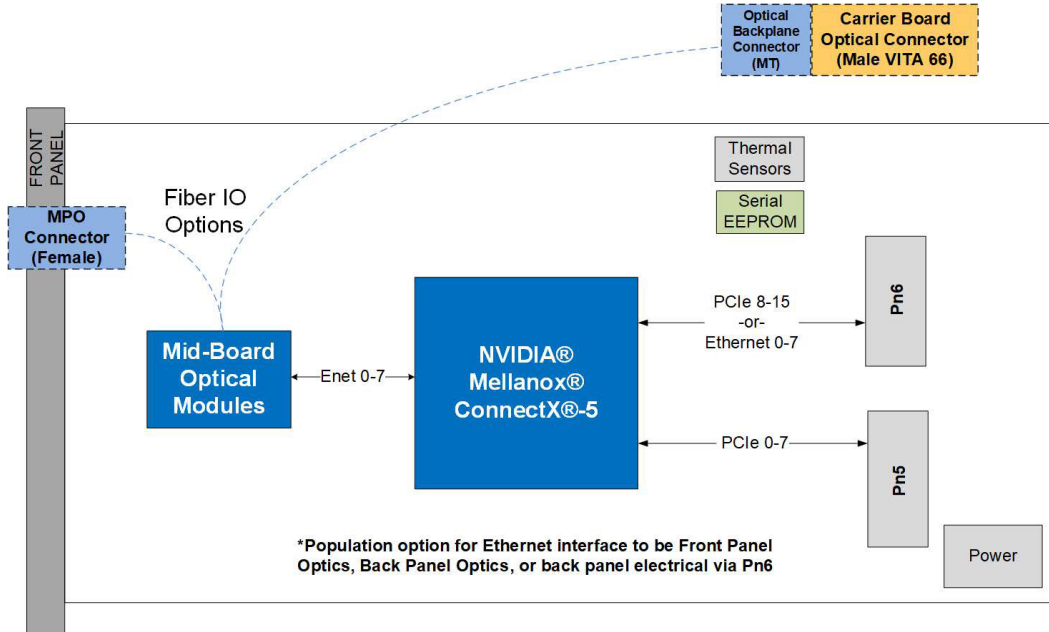

> V1160 XMC Block Diagram

Connector Types

The V1160 offers five different I/O options:

- Electrical Backplane Connector via Pn6
- Optical Front Panel MPO Connector (Female)
- Optical Backplane MT Connector for VITA 66.5
- Custom Optical Cabling/Connector Options

Backplane Slot Profile

When hosted on a New Wave VPX carrier, the V1160 provides a VITA 46.9 P1w9-X12d+“X4d” compliant interface.

- “X4d” includes 4 pairs beyond the standard on P1w15 A/B, D/E and P1w16 B/C, E/F.

1. Front Panel MPO (Female) I/O

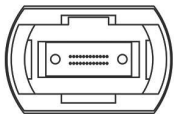

2. VITA 66.5 Backplane MT I/O¹

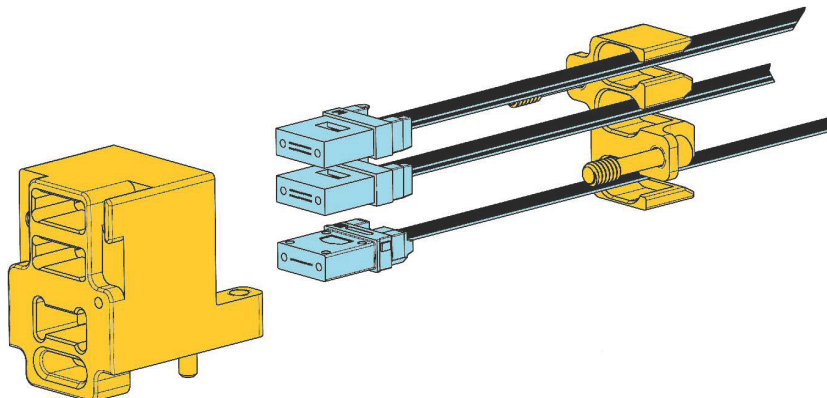

KEY	
■	New Wave-Provided Hardware
■	Customer-Provided Hardware

¹Common Terminations: VITA 66.5 Style C, Style D (pictured)

V1160

Dual-Port 100G Rugged Ethernet XMC Card

Multi-Processor Multi-Core Support

The V1160 is uniquely suited for system architectures involving multiple processing cards on a common switched data plane. Specifically, the V1160 supports shared access from multiple host processors, enabling it to function as a cost-effective, high-performance gateway. This feature enables a single high-speed pipe to carry multiple virtual channels in systems that need to spread or load-balance sensor data across processor arrays.

Complete Product Support Program

New Wave DV prides itself on its excellent customer support, a fact that is echoed by our customers. New Wave DV provides industry standard warranty on its products, but it is the human factor that makes our support so valuable to our customers. Our team takes the time and effort to ensure that the customer experience with our products is a positive one.

Our Commitment

New Wave DV is committed to providing the latest innovations in technology, architectures, and techniques to keep our customers one step ahead of the rest. Our products, complete with the Development Framework, are intended to offer our customers an entirely unique out-of-the-box experience.

Alternate Form Factors

The V1160 is designed for use in a variety of mission-critical applications. Whether you need its capabilities in XMC or other form factors such as VPX, PCIe (double-width), PXIe, or others, we're happy to help accommodate your needs and provide you with the solution best suited for your success.



Technical Specifications

NETWORK INTERFACE

Dual 10/25/40/50/100Gbps Ethernet ports Front/backplane 850nm multi-mode optics or electrical ports to Pn6 (high-speed mezzanine connector)

ETHERNET PROTOCOLS

TCP, UDP, ARP, ICMP, RoCE v2, Multicast, Broadcast, + more
Visit [NVIDIA® Mellanox® Datasheet1](#)

ETHERNET DEVICE

NVIDIA® Mellanox® ConnectX-5 EN IC
Visit [NVIDIA® Mellanox® Datasheet1](#)

HOST INTERFACE

PCI Express Gen4/Gen3 x8 (Pn5) PCI
Express Gen4/Gen3 x16 (Pn5 & Pn6)

THERMAL SENSORS

2 digital temperature sensors

COMPLIANCE

VITA 20, 42.3, 47, 61.0, 66.5, 88
NVIDIA® Mellanox® ConnectX-5 EN IC
Visit [NVIDIA® Mellanox® Datasheet1](#)

SOFTWARE SUPPORT

Software drivers available from NVIDIA® Mellanox®2
NWDV Maintained OS's: <https://newwavedv.com/products/fpga-interface-cards/pmc-xmc/1160/1160-software-info.pdf/>

PHYSICAL CHARACTERISTICS

Dimensions: 74 mm (width) x 143.75 mm (length)
Weight: 0.276 lbs

POWER CHARACTERISTICS

Power Draw: Maximum 25W
Power Supply: 5V to 12V

TEMPERATURE

Operating: -40° C to 55° C at 250 LFM (air-cooled)
Operating: -40° C to 85° C (conduction-cooled)
Storage: -55° C to 105° C

This hardware can also support InfiniBand.

Please reach out for more information.

1NVIDIA® Mellanox® ConnectX-5 EN IC Datasheet:
https://newwavedv.com/wordpress/wp-content/uploads/2023/01/pb_connectx-5_en_ic.pdf

2NVIDIA® Mellanox® Ethernet Software Support/Datasheet:
<https://developer.nvidia.com/networking/ethernet-software>

V1160 Hardware Part Number Configuration

400 - **01160**
Series Model

“WXYZ”

Board Configuration

Select 1 for each W, X, Y, and Z

IP Configuration

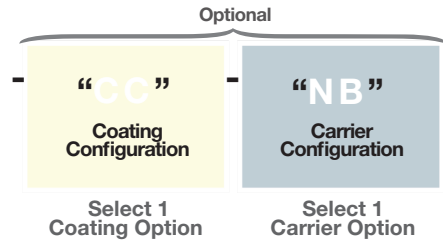

W

Config #	Description
7+	Reserved
6	No optics populated, electrical backplane IO
5	Front Panel 10Gbps optics
4	Front Panel 25Gbps optics
3	Backplane 10Gbps VITA66 MT-12 V65.0-6.5.2.2
2	Backplane 25Gbps VITA66 MT-12 V65.0-6.5.2.2
1	Backplane 10Gbps VITA66 MT-24 V65.0-6.5.3.5
0	Backplane 25Gbps VITA66 MT-24 V65.0-6.5.3.5

X

Config #	Description
4+	Reserved
3	Dual-Port w/ single lane support (10/25Gbps)
2	Dual-port w/ bonded lane support (40/100Gbps)
1	Single-Port w/ single lane support (10/25Gbps)
0	Single-Port w/ bonded lane support (40/100Gbps)

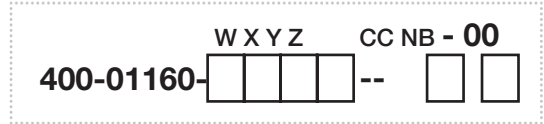

CC

Config #	Description
AR	Acrylic conformal coat
UR	Urethane conformal coat
ER	Epoxy conformal coat
SR	Silicone conformal coat
XY	Parylene conformal coat
BLANK	No conformal coat

Y

Config #	Description
9	VITA 88 mezzanine connector(s), P16 connector populated
8	VITA 88 mezzanine connector(s), P16 connector not populated
7, 6	Reserved
5	VITA 61 mezzanine connector(s), P16 connector populated
4	VITA 61 mezzanine connector(s), P16 connector not populated
3	VITA 42 mezzanine connector(s), P16 connector populated
2	VITA 42 mezzanine connector(s), P16 connector not populated
1, 0	Reserved

Z

Config #	Description
F	Reserved
E	PCIe Gen3, commercial temp, multi-host, PCIe switch disabled
D	PCIe Gen3, commercial temp, single-host, PCIe switch enabled
C	PCIe Gen3, commercial temp, single-host, PCIe switch disabled
B	Reserved
A	PCIe Gen3, industrial temp, multi-host, PCIe switch disabled
9	PCIe Gen3, industrial temp, single-host, PCIe switch enabled
8	PCIe Gen3, industrial temp, single-host, PCIe switch disabled
7	Reserved
6	PCIe Gen4, commercial temp, multi-host, PCIe switch disabled
5	PCIe Gen4, commercial temp, single-host, PCIe switch enabled
4	PCIe Gen4, commercial temp, single-host, PCIe switch disabled
3, 2, 1, 0	Reserved

NB

Config #	Description
PE	XMC delivered in PCIe form factor via carrier card
3V	XMC delivered in conduction-cooled 3U VPX form factor
3A	XMC delivered in air-cooled 3U VPX form factor
PX	XMC delivered in PXle form factor via carrier card
BLANK	XMC delivered in XMC form factor without carrier card Additional options available. Please inquire.

V1160 Hardware Part Number Configuration

Part Numbers from Table 2 are available with the shortest lead times.

Table 2

Front Panel Optical Variants

Config #	Description
400-01160-4254-00	V1160 Ethernet XMC Card, dual port, front panel 25Gbps optics, bonded lanes enabled (40/100G Ethernet support), VITA 61 mezzanine connector(s), P16 mezzanine connector populated, PCIe Gen4, commercial temp, single host, PCIe switch disabled
400-01160-4258-00	V1160 Ethernet XMC Card, dual port, front panel 25Gbps optics, bonded lanes enabled (40/100G Ethernet support), VITA 61 mezzanine connector(s), P16 mezzanine connector populated, PCIe Gen3, industrial temp, single host, PCIe switch disabled

VITA 66 Optical Variants

Config #	Description
400-01160-0254-00	V1160 Ethernet XMC Card, dual port, backplane 25Gbps VITA 66.5 / 67.3 optics, bonded lanes enabled (40/100G Ethernet support), VITA 61 mezzanine connector(s), P16 mezzanine connector populated, PCIe Gen4, commercial temp, single host, PCIe switch disabled
400-01160-0258-00	V1160 Ethernet XMC Card, dual port, backplane 25Gbps VITA 66.5 / 67.3 optics, bonded lanes enabled (40/100G Ethernet support), VITA 61 mezzanine connector(s), P16 mezzanine connector populated, PCIe Gen3, industrial temp, single host, PCIe switch disabled

No Optics

Config #	Description
400-01160-6254-00	V1160 Ethernet XMC Card, dual port, backplane electrical, bonded lanes enabled (40/100G Ethernet support), VITA 61 mezzanine connector(s), P16 mezzanine connector populated, PCIe Gen4, commercial temp, single host, PCIe switch disabled
400-01160-6258-00	V1160 Ethernet XMC Card, dual port, backplane electrical, bonded lanes enabled (40/100G Ethernet support), VITA 61 mezzanine connector(s), P16 mezzanine connector populated, PCIe Gen3, industrial temp, single host, PCIe switch disabled

FOR MORE INFORMATION

www.newwavedv.com
 info@newwavedv.com
 Phone +1 952-224-9201

New Wave Design
 10260 Viking Drive, Ste 250
 Eden Prairie, MN 55344 USA