

Ethernet force-distance measurement system, 1 counter input input, 4 inputs for strain gauges, 24-bit, 2 digital I/O, 24 V

New!*



MSX-E3317

- 1 counter input
- 4 inputs for strain gauges, diff, 24-bit
- 2 digital I/O, 24 V
- Easy configuration: Easy mode



Integrated Ethernet switch



*Operating temperature



ARM9 Technology

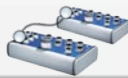

Cascadable, can be synchronised in the μ s range

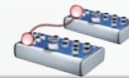

On request: Compare logic for synchro trigger signal



on request



DatabaseConnect on request, see page 112



More information on www.addi-data.com

Features

- 24 V digital trigger input
- ARM9 32-bit processor
- 64 MB onboard SDRAM for storing data
- Robust standardized metal housing
- Power Save Mode: Reduced power consumption when no acquisition runs

Safety features

- Status LEDs for fast error diagnostics
- Optical isolation • Input filters

Counter input

- 1 incremental counter input, 32-bit, (on request: Sin/Cos 1 V_{pp} or Sin/Cos 11 μ App) 12-pin M23 female connector
- Max. input frequency 5 MHz

Inputs for strain gauges

- 4 inputs for strain gauges, 24-bit, M12 female connector, 8-pin
- Sampling frequency max. 788 Hz/channel (max. 2 channels simultaneously)

Digital I/O

- 1 x 2 digital lines, 24 V, which can be parameterised as pairs of inputs or outputs
- Shutdown logic
- At Power-On the outputs are set to „0“
- Electronic fuse
- Dual LED for each 24 V dig. I/O with direction indication

Interfaces

- Fast 24 V trigger input
- Ethernet switch with 2 ports
- Synchronisation/trigger In/Out
- Line in for 24 V supply and cascading

Communication interfaces

- Web server (configuration and monitoring)
- Command server SOAP for transferring commands
- Data server (TCP/IP or UDP socket) for sending acquisition data
- Event server (TCP/IP socket) for sending system events (Diagnostics such as temperature, short-circuits ...)
- Command server Modbus TCP and Modbus (UDP) for sending commands

Synchronisation/time stamp

Time stamp

Several MSX-E systems can be synchronised with one another in the μ s range through a synchro connection. This allows to start a synchronous data acquisition, to generate trigger events and to synchronise the time on several MSX-E systems. Furthermore, the systems have a time stamp that logs the point in time at which the data was acquired by the system.

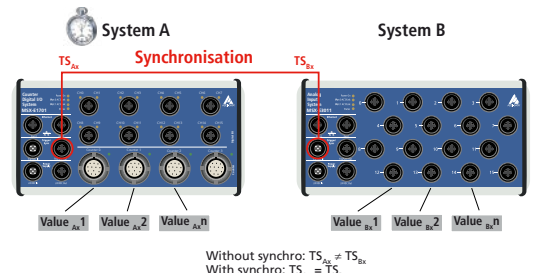

The combination of synchronisation and time stamp (TS) allows the clear allocation of signals that were captured by several systems.

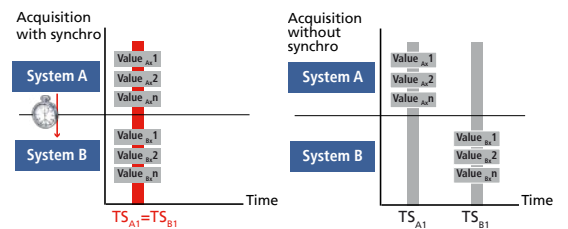

* Preliminary Product information



Acquisition modes

With the MSX-E3317 system, you can effect force-distance measurements in 2 different ways: in auto-refresh mode or sequence mode. The acquisition can be done depending on a position or on time.

Auto-refresh mode

In the auto-refresh mode, the measurement values are updated automatically after each acquisition. The acquisition is initialised once and the values of the channels are stored in the memory of the MSX-E Ethernet system. The client (e.g. PC, server, PLC, ...) reads the acquired values asynchronously to the acquisition through socket connection, SOAP or Modbus function. Thereby, the new value is read and the old values are overwritten. In addition to the measurement values, the auto-refresh counter can also be read, which allows to sort the measurement values chronologically. The auto-refresh mode can be combined with a hardware or a synchro trigger and also allows the automatic averaging of values.

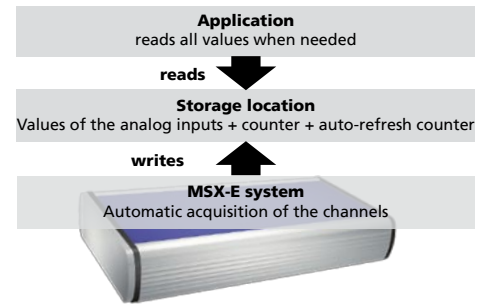

Sequence mode

In the sequence mode, a list of channels is acquired. Thereby, the single measurement rows are stored one after another. The client receives the acquired values asynchronously to the acquisition through a socket connection. In the sequence mode, the measurement values are read in chronological order, this means the oldest values are read first. The acquisition can be effected continuously, with or without delay or in combination with a hardware or synchro trigger.

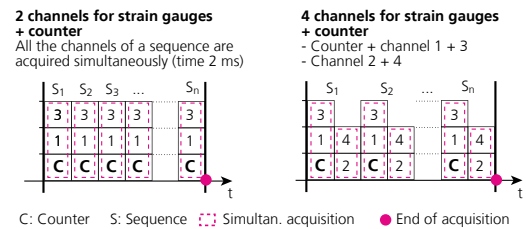

Acquisition triggered through trigger or synchro input

Example: A measurement process is to be started through an external trigger impulse. For each trigger, 10 sequences are to be acquired. After the acquisition of the 10 sequences they are to be sent to the client.

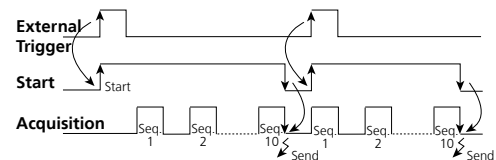

Reading data from a MSX-E system

MSX-E systems are multi-client capable, this means several clients (e. g. PC, server, PLC, ...) can read the measurement values of one MSX-E system at the same time. For this, each client establishes a socket connection to the data server of the MSX-E system (port 8989). As soon as the measurement values are available on the data server, the MSX-E system transfers them to the clients.

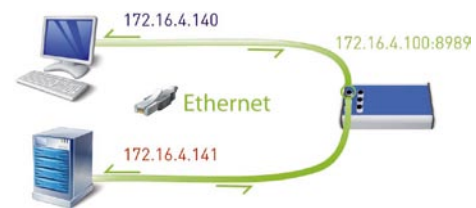

Onboard programming

Development mode

With the Development mode of the MSX-E systems you can customise your measurement, control and regulation applications to fit your requirements. The programs run directly on the MSX-E systems, which has two advantages: external PCs are relieved and you can process data freely according to your requirements. This helps you to improve the efficiency of your processes and to secure your investments.

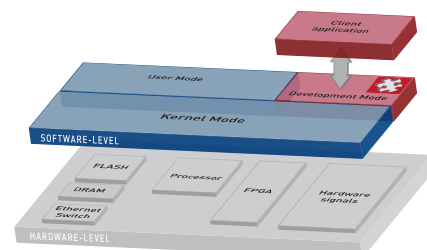

* Preliminary product information

ConfigTools

The **ConfigTools** program allows an easy administration of the MSX-E systems. These are automatically detected in the network. **ConfigTools** consists of common and specific functions. In addition, with **ConfigTools**, the complete configuration of a MSX-E system can be saved and transferred to another system of the same type (clone function).

ConfigTools is included in the delivery.

ConfigTools functions for MSX-E3317:

- Change of IP address
- Display of web interface
- Firmware update
- Save/load system configuration
- Save/load channel configuration
- Monitor for Inputs for strain gauges
- Visualisation of the force-distance measurement (Easy mode)

Very easy use through the „ConfigTools“ program; The MSX-E system is automatically detected in the network.

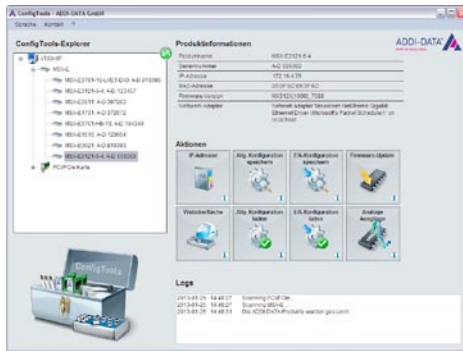

Features

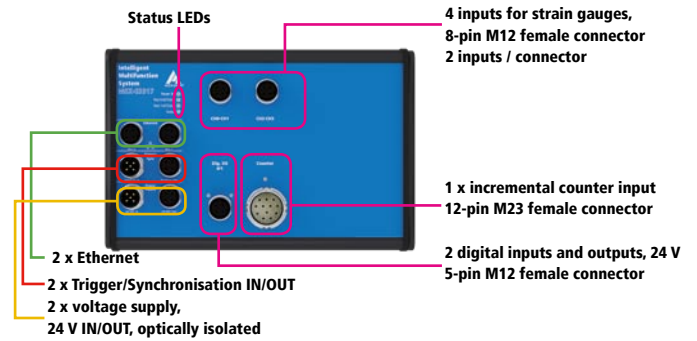

Simplified block diagram

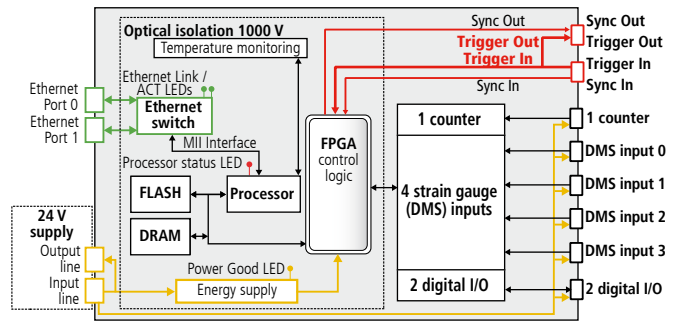

Cascading

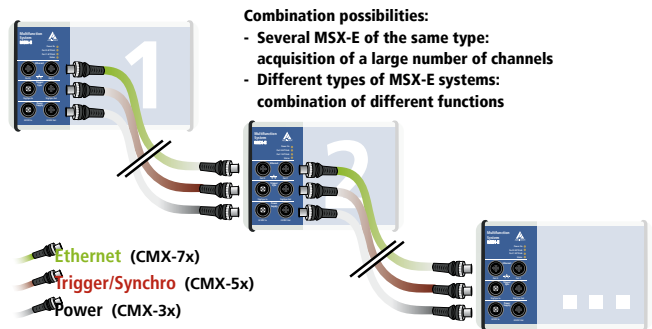

ADDI-DATA connection technology

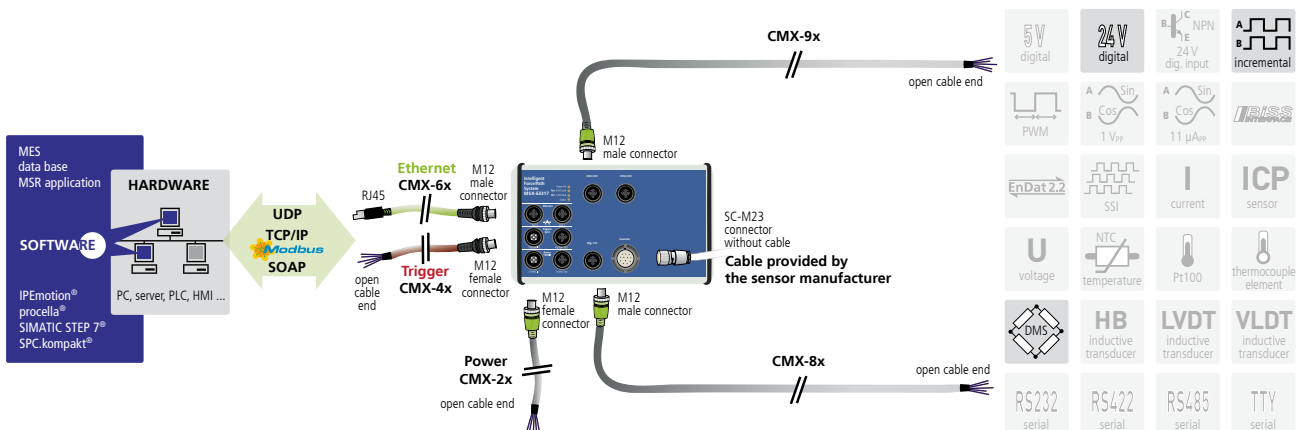

* Preliminary product information



Specifications*

Incremental counter

Number of counter inputs:	1
Input type:	Differential or TTL inputs
Differential inputs:	Complies with the EIA standards RS422A
Common mode range:	+12 / -7 V
Input sensitivity:	± 200 mV
Input hysteresis:	50 mV typ.
Input impedance:	12 kΩ min.
Max. input frequency:	5 MHz at nominal voltage
„Open Circuit Fail Safe	
Receiver Design“	„1“ = inputs open
ESD protection:	Up to ±15 kV
Voltage supply	
Incremental encoder:	5 V or 24 V, max. 500 mA

Inputs for strain gauges

Number of inputs:	4 differential inputs for strain gauges 2 inputs per M12 connector
Resolution:	24-bit
Optical isolation:	1000 V
Throughput per M12 connector:	max. 788 Hz for 1 channel, max. 528 Hz for 2 channels
Voltage supply for the sensors:	10 V, 50 mA
Trigger:	Digital input, synchro, software-programmable

Digital inputs

Number of inputs:	2, on 1 M12 female connector, Common ground acc. to IEC 1131-2
Overvoltage protection:	30 V
Optical isolation:	1000 V through opto-couplers
Nominal voltage:	24 VDC
Input voltage:	0 to 30 V
Input impedance:	> 1 MΩ
Logic input levels:	UH (max) 30 V typ. UH (min) 18 V typ. UL (max) 16 V typ. UL (min) 0 V typ.

Digital outputs

Number of outputs:	2, on 1 M12 female connector
Optical isolation:	1000 V through opto-couplers
Output type:	High-side, load to ground acc. to IEC 1131-2
Nominal voltage:	24 V
Voltage supply:	18 V-30 V
Current (max.):	1.85 A typical for 2 channels through PTC
Output current / output:	500 mA max.
Short-circuit current / output:	1.7 A max. Shut-down logic at 24 V, $R_{load}=10m\Omega$
RDS ON Resistance:	280 mΩ max.
Switch-on time:	100 μs max RL=48 Ω von 80 % V_{out}
Switch-off time:	150 μs max RL=48 Ω von 10 % V_{out}
Overtemperature (shutdown):	135°C max. (output driver)
Temperature hysteresis:	15°C typ. (output driver)
Diagnostics:	Common diagnostics bit at overtemperature

Voltage supply, Ethernet, Trigger, Synchro

The specifications for the voltage supply, Ethernet, Trigger, Synchronisation and Electromagnetic Compatibility apply to all MSX-E systems. See page 27.

System features

Interface:	Ethernet acc. to specification IEEE802.3
Dimensions:	220 x 140 x 50 mm
Weight:	ca. 900 g
Degree of protection:	IP 65
Current consumption at 24 V:	150 mA without load
Operating temperature:	-40 °C to +85 °C

Connectors for sensors

For inputs for strain gauges:	2 x 8-pin female connector M12
For digital I/O:	1 x 5-pin M12 female connector
For the counter input:	1 x 12-pin M23 female connector

Ordering information

MSX-E3317

Ethernet force-distance measurement system, 1 counter input, 4 inputs for strain gauges, 24-bit, 2 digital I/O, 24 V.
Incl. technical description, software drivers and ConfigTools.

Connection cables

Voltage supply

CMX-2x: Shielded cable, M12 5-pin female connector/open end, IP 65

CMX-3x: For cascading, shielded cable, M12 5-pin female connector/male connector IP 65

Trigger/Synchro

CMX-4x: Shielded cable, M12 5-pin female connector/open end, IP 65

CMX-5x: For cascading, shielded cable, M12 5-pin female connector/male connector IP 65

Ethernet

CMX-6x: CAT5E cable, M12 D-coded male connector/RJ45 connector

CMX-7x: For cascading, CAT5E cable, 2 x M12 D-coded male connector

Connection to peripherals

CMX-8x: Shielded cable, M12 5-pin male connector/open end, IP 65

CMX-9x: Shielded cable, M12 8-pin male connector/open end, IP 65

Options

S7 Modbus TCP Client Library for S7: Easy use of the Ethernet systems MSX-E with PLCs

MSX-E 5V-Trigger: Level change of the trigger inputs and outputs to 5 V

MX-Clip, MX-Rail (please specify when ordering!),

MX-Screw, PCMX-1x

* Preliminary product information