

Ethernet analog input system

16 analog inputs, diff., 16-bit

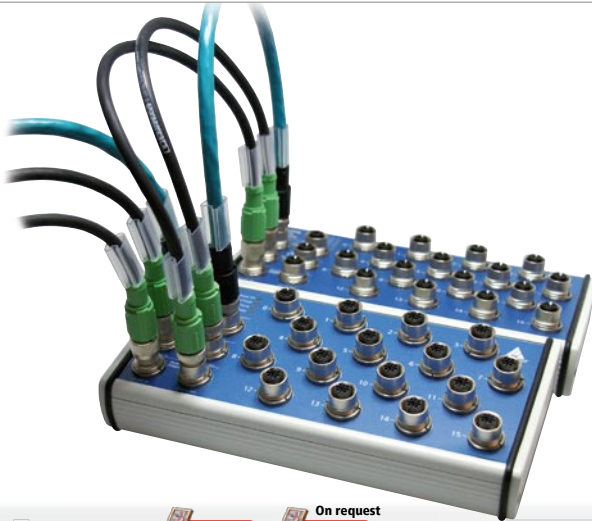

MSX-E3021

16 analog inputs, differential, 16-bit









Voltage or current inputs

Simultaneous acquisition of 4 channels with 100 kHz per channel

4 GB extended memory

Buffered real-time clock

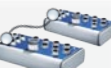
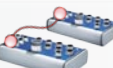
24 V digital trigger input

 Integrated Ethernet switch
 +85 °C*
 -25 °C
 +85 °C*
 -40 °C
 IP 65
 ARM⁹ Technology
 Cascadable, can be synchronised in the µs range
 On request: Compare logic for synchro trigger signal
 4 GB flash memory, real-time clock
 *Operating temperature



on request



DatabaseConnect
see page 112



More information on
www.addi-data.com

Features

- 24 V digital trigger input
- ARM⁹ 32-bit processor
- 64 MB onboard SDRAM for storing data
- Robust standardized metal housing
- Power Save Mode: Reduced power consumption when no acquisition runs

Analog inputs

- 16 diff. inputs, 16-bit, 5-pin M12 female connector
- Sampling frequency max. 100 kHz, up to 4 simultaneous channels
- Input ranges: ±5 V, ±10 V (16-bit), 0-5 V, 0-10 V (15-bit)
- Gain PGA x1, x2, x10, x20, x100, x200, x1000, x2000 software-programmable, signals up to ±5mV (16-bit) are possible
- Current inputs optional

Safety features

- Status LEDs for fast error diagnostics
- Optical isolation • Input filters
- Overvoltage protection ± 40 V
- Internal temperature monitoring

Interfaces

- Fast 24 V trigger input
- Ethernet switch with 2 ports
- Synchronisation/trigger In/Out
- Line in for 24 V supply and cascading

Communication interfaces

- Web server (configuration and monitoring)
- Command server SOAP for transferring commands
- Data server (TCP/IP or UDP socket) for sending acquisition data
- Event server (TCP/IP socket) for sending system events (Diagnostics such as temperature, short-circuits ...)
- Command server Modbus TCP and Modbus (UDP) for sending commands

Synchronisation/time stamp

Time stamp

Several MSX-E systems can be synchronised with one another in the µs range through a synchro connection. This allows to start a synchronous data acquisition, to generate trigger events and to synchronise the time on several MSX-E systems. Furthermore, the systems have a time stamp that logs the point in time at which the data was acquired by the system.

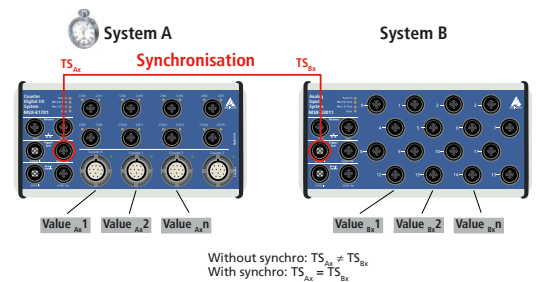

The combination of synchronisation and time stamp (TS) allows the clear allocation of signals that were captured by several systems.

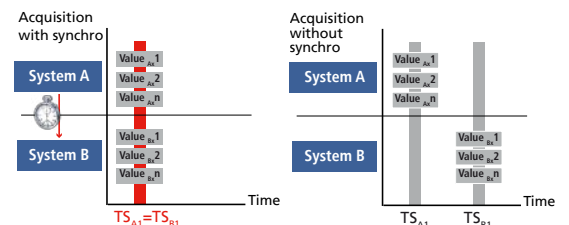

* Preliminary
Product information

Acquisition modes

Auto-refresh mode

In auto-refresh mode, the measurement values are updated automatically after each acquisition. The acquisition is initialised once and the values of the channels are stored in the memory of the MSX-E Ethernet system. The client (e.g. PC, server, PLC, ...) reads the acquired values asynchronously to the acquisition through socket connection, SOAP or Modbus function. Thereby, the new value is read and the old values are overwritten. In addition to the measurement values, the auto-refresh counter can also be read, which allows to sort the measurement values chronologically. The auto-refresh mode can be combined with a hardware or a synchro trigger and also allows the automatic averaging of values.

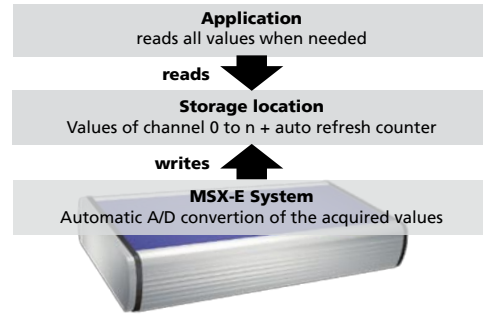

Sequence mode

In sequence mode, a list of channels is acquired. Thereby, the single measurement rows are stored one after another. The client receives the acquired values asynchronously to the acquisition through a socket connection. In the sequence mode, the measurement values are read in chronological order, this means the oldest values are read first. The acquisition can be effected continuously, with or without delay or in combination with a hardware or synchro trigger.

Example: 8 channels, each with 10 μ s

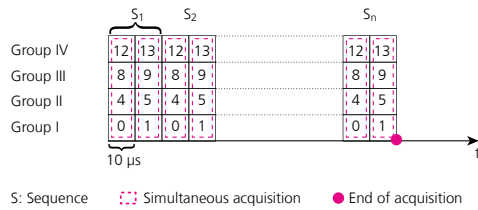

Horizontal wiring (with 4 gauges/sensors)

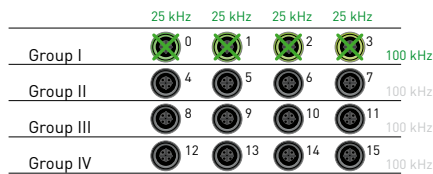

Vertical wiring (with 4 gauges/sensors)

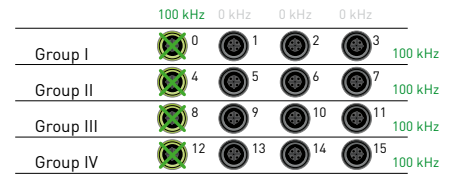

Acquisition speed

Different wiring

for 25 kHz/channel and 100 kHz/groups

Acquisition triggered through trigger or synchro input

Example: A measurement process is to be started through an external trigger impulse. For each trigger, 10 sequences are to be acquired. After the acquisition of the 10 sequences they are to be sent to the client.

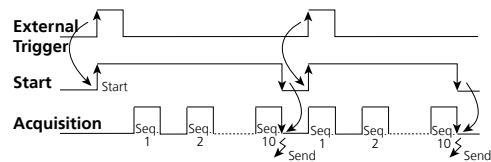

Reading data from a MSX-E system

MSX-E systems are multi-client capable, this means several clients (e. g. PC, server, PLC, ...) can read the measurement values of one MSX-E system at the same time. For this, each client establishes a socket connection to the data server of the MSX-E system (port 8989). As soon as the measurement values are available on the data server, the MSX-E system transfers them to the clients.

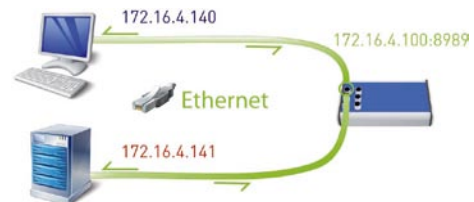

Onboard programming / stand-alone operation

Development mode

With the Development mode of the MSX-E systems you can customise your measurement, control and regulation applications to fit your requirements. The programs run directly on the MSX-E systems, which has two advantages: external PCs are relieved and you can process data freely according to your requirements. This helps you to improve the efficiency of your processes and to secure your investments.

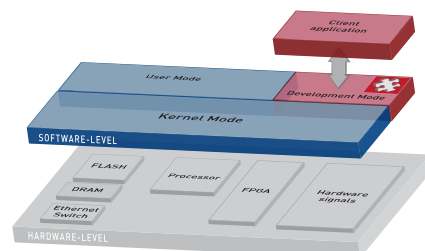

* Preliminary product information

ConfigTools

The **ConfigTools** program allows an easy administration of the MSX-E systems. These are automatically detected in the network. **ConfigTools** consists of common and specific functions. In addition, with **ConfigTools**, the complete configuration of a MSX-E system can be saved and transferred to another system of the same type (clone function).

ConfigTools is included in the delivery.

ConfigTools functions for MSX-E3021:

- Change of IP address
- Display of web interface
- Firmware update
- Save/load system configuration
- Save/load channel configuration
- Monitor for analog inputs

Very easy use through the „ConfigTools“ program; The MSX-E system is automatically detected in the network.

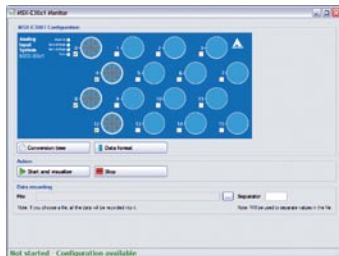
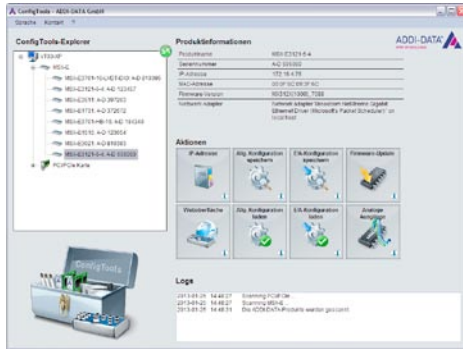

Example of monitor function: Testing the analog inputs.

Features

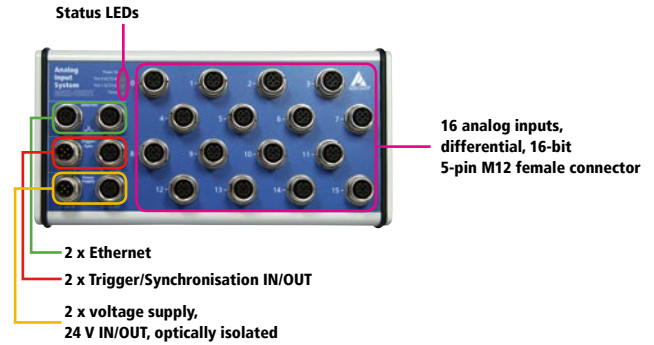

Simplified block diagram

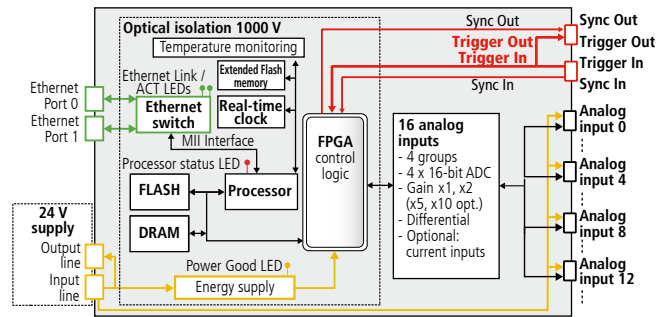

Cascading

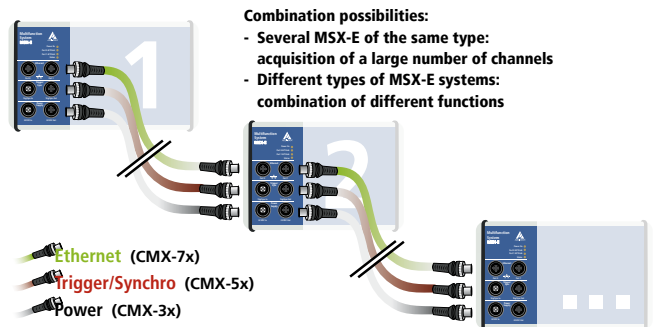

- Combination possibilities:**
- Several MSX-E of the same type: acquisition of a large number of channels
 - Different types of MSX-E systems: combination of different functions

ADDI-DATA connection technology

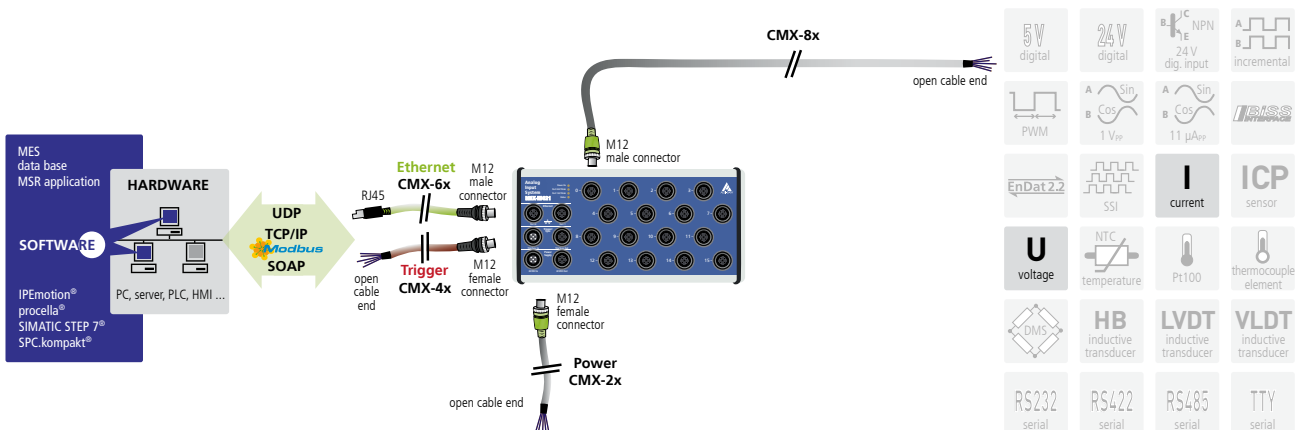

* Preliminary product information

Specifications*

Analog inputs

Number/type:	16 differential inputs
Architecture:	4 groups of 4 channels each 4-port simultaneous converter with one 4-channel multiplexer per converter
Resolution:	16-bit, SAR ADC
Accuracy:	± 1.221 mV typ. (± 4 LSB) ± 2.442 mV max.
Relative Accuracy (INL):	± 3 LSB max (ADC)
Optical isolation:	1000 V
Input ranges:	± 5 V, ± 10 V (16-bit), 0-5 V, 0-10 V (15-bit) current inputs optional
Sampling frequency:	25 kHz per channel / 100 kHz max.
Gain:	x1, x2, x10, x20, x100, x200, x1000, x2000 software-programmable
Common mode rejection:	80 dB min. DC up to 60 Hz (diff. amplifier)
Input impedance (PGA):	$10^9 \Omega // 10\text{nF}$ against GND
Bandwidth (-3dB):	160 kHz limited through TP filters 16 Hz version with differential filter
Trigger:	digital input, synchro, software-programmable
Offset error:	± 1 LSB ($\pm 305 \mu\text{V}$)
Gain error:	± 2.5 LSB
Temperature drift :	$2.3 \times V_{in} + 22.5$ ($\mu\text{V}/^\circ\text{C}$) typ. V_{in} : input voltage in Volts ($-10\text{V} \leq V_{in} \leq +10\text{V}$) In the temperature range from -40°C to $+85^\circ\text{C}$: 4.5 ppm/ $^\circ\text{C}$ FSR

Data storage

RAM:	64 MB
FLASH:	4 MB for system data
Extended FLASH memory:	4 GB (3.7 GB for measured data)
Buffered real-time clock:	approx. 4 weeks at 20°C

Voltage supply, Ethernet, Trigger, Synchro

The specifications for the voltage supply, Ethernet, Trigger, Synchronisation and Electromagnetic Compatibility apply to all MSX-E systems. See page 27.

System features

Interface:	Ethernet acc. to specification IEEE802.3
Dimensions:	215 x 110 x 50 mm
Weight:	850 g
Degree of protection:	IP 65
Current consumption at 24 V:	180 mA
Operating temperature:	-25°C to $+85^\circ\text{C}$ -40°C to $+85^\circ\text{C}$ on request

Connectors for sensors

For analog inputs: 8 x 5-pin M12 female connector

Ordering information

MSX-E3021

Ethernet analog input system, 16 analog inputs, diff., 16-bit. Incl. technical description, software drivers and ConfigTools.

Connection cables

Voltage supply

CMX-2x: Shielded cable, M12 5-pin female connector/open end, IP 65

CMX-3x: For cascading, shielded cable, M12 5-pin female connector/male connector IP 65

Trigger/Synchro

CMX-4x: Shielded cable, M12 5-pin female connector/open end, IP 65

CMX-5x: For cascading, shielded cable, M12 5-pin female connector/male connector IP 65

Ethernet

CMX-6x: CAT5E cable, M12 D-coded male connector/RJ45 connector

CMX-7x: For cascading, CAT5E cable, 2 x M12 D-coded male connector

Connection to peripherals

CMX-8x: Shielded cable, M12 5-pin male connector/open end, IP 65

Options

PC-Diff: Current input 0(4)-20 mA for 1 input, diff.
(please indicate the number of channels)

S7 Modbus TCP Client Library for S7: Easy use of the Ethernet systems MSX-E with PLCs

MSX-E 5V-Trigger: Level change of the trigger inputs and outputs to 5 V

MX-Clip, MX-Rail (please specify when ordering!),

MX-Screw, PCMX-1x

* Preliminary product information