

Ethernet digital I/O system

16 digital I/O, 24 V, with event logic

New!*
MSX-E 1516-NPN

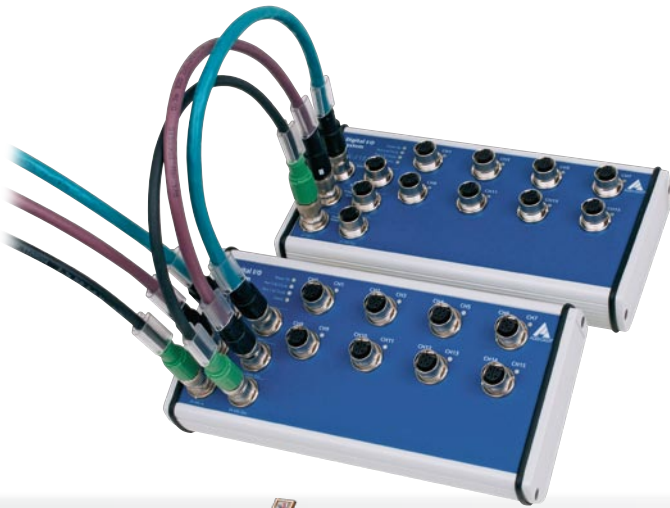

MSX-E1516, MSX-E1516-NPN

16 digital I/O, 24 V, status LEDs

Configurable inputs and outputs

Event logic for the inputs and outputs

24 V digital trigger input

M12 connectors



Integrated Ethernet switch



*Operating temperature



ARM⁹ Technology

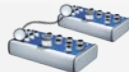

Cascadable, can be synchronised in the μ s range

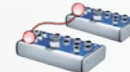

Timer function for synchro trigger signal



on request



DatabaseConnect see page 112



More information on www.addi-data.com

Features

- 24 V digital trigger input
- ARM⁹ 32-bit processor
- 64 MB onboard SDRAM for storing data
- Robust standardized metal housing
- Power Save Mode: Reduced power consumption when no acquisition runs

Safety features

- Status LEDs for fast error diagnostics
- Optical isolation 1000 V
- Overtemperature and reverse voltage protection
- Internal temperature monitoring
- Filters on all inputs (software-programmable)
- Short-circuit protection
- Overvoltage protection 30 V
- Electronic fuse

Digital I/O

- 8 x 2 digital lines, 24 V, which can be parameterised as pairs of inputs or outputs
- Shutdown logic
- Watchdog for resetting the outputs to „0“
- At Power-On the outputs are set to „0“
- Electronic fuse
- Dual LED for each 24 V digital I/O with direction indication

Interfaces

- Fast 24 V trigger input
- Ethernet switch with 2 ports
- Synchronisation/trigger In/Out
- Line in for 24 V supply and cascading

Communication interfaces

- Web server (configuration and monitoring)
- Command server SOAP for transferring commands
- Data server (TCP/IP or UDP socket) for sending acquisition data
- Event server (TCP/IP socket) for sending system events (Diagnostics such as temperature, short-circuits ...)
- Command server Modbus TCP and Modbus (UDP) for sending commands

Synchronisation/time stamp

Time stamp

Several MSX-E systems can be synchronised with one another in the μ s range through a synchro connection. This allows to start a synchronous data acquisition, to generate trigger events and to synchronise the time on several MSX-E systems. Furthermore, the systems have a time stamp that logs the point in time at which the data was acquired by the system.

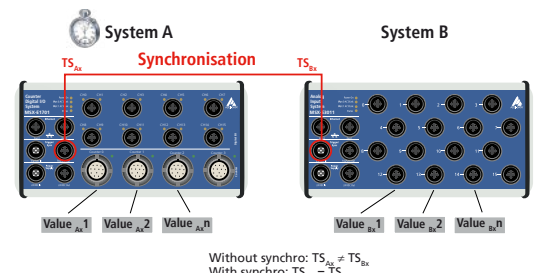

The combination of synchronisation and time stamp (TS) allows the clear allocation of signals that were captured by several systems.

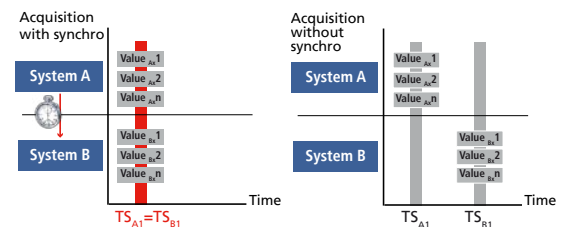

NOTE

NPN

While most sensors when activated will output a 24V signal (PNP sensors), a NPN sensor when activated switches to ground.

The switching to ground of NPN sensors can be read by the MSX-E1516-NPN system.



Acquisition modes

Acquisition modes – There are 2 different possibilities for reading the digital inputs.

1. Asynchronous acquisition

With the asynchronous acquisition, the digital inputs can be read out via SOAP or Modbus function. For each function call, the values of one channel are transmitted.

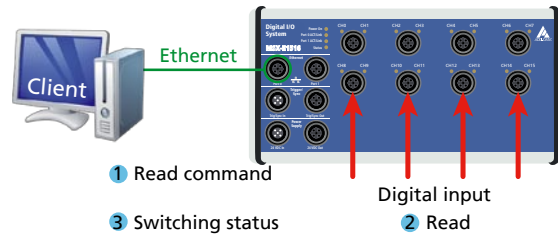

2. Synchronous acquisition

With the synchronous acquisition, the inputs are first initialised and then the acquisition is parameterised. The acquisition runs automatically depending from a trigger source.

Either the 24V trigger input or a synchro trigger can be used as trigger source.

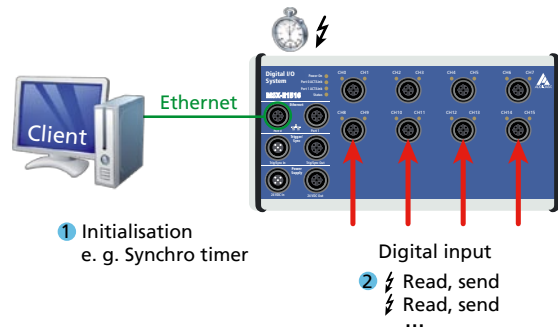

Synchro latch

A periodic acquisition of the digital inputs is possible using the synchro timer (synchro latch). Several MSX-E systems (of same or different types) can be combined through synchro trigger. With the synchronous acquisition, as soon as there are measurement values available, they are sent to the clients via socket connection.

Event logic

The event logic of the MSX-E1516 can be used to detect a change of edge on the digital inputs (e.g. to show that 1 unit has been produced, or that the machine runs or stands still).

This information (time stamp + event mask) is stored on the data server of the MSX-E1516 and can be read through a socket connection.

The information can be read either through an application written for this purpose or by using the DatabaseConnect software. DatabaseConnect writes the information in a database and can then evaluate it.

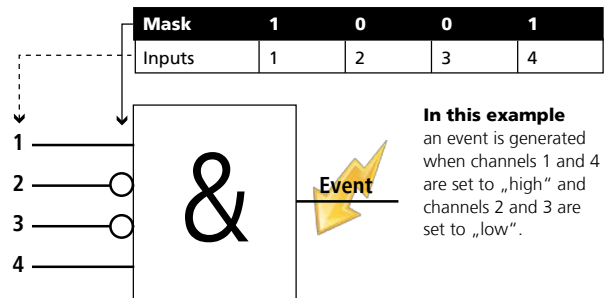

Onboard programming / stand-alone operation

Development mode

With the Development mode of the MSX-E systems you can customise your measurement, control and regulation applications to fit your requirements. The programs run directly on the MSX-E systems, which has two advantages: external PCs are relieved and you can process data freely according to your requirements. This helps you to improve the efficiency of your processes and to secure your investments.

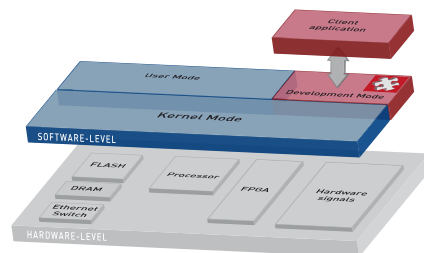

Safety

Watchdog

The MSX-E1516 Ethernet system has a 16-bit watchdog which can be programmed in 3 time units (µs, ms, s). The watchdog is used for automatically resetting the digital outputs to 0 V after a defined time in order e.g. to switch off actuators if an error has occurred.

* Preliminary product information

ConfigTools

The **ConfigTools** program allows an easy administration of the MSX-E systems. These are automatically detected in the network. **ConfigTools** consists of common and specific functions. In addition, with **ConfigTools**, the complete configuration of a MSX-E system can be saved and transferred to another system of the same type (clone function).

ConfigTools is included in the delivery.

ConfigTools functions for MSX-E1516, MSX-E1516-NPN:

- Change of IP address
- Display of web interface
- Firmware update
- Save/load system configuration
- Save/load channel configuration

Very easy use through the „ConfigTools“ program; The MSX-E system is automatically detected in the network.

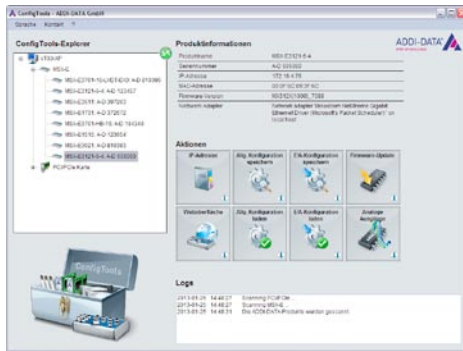

Features

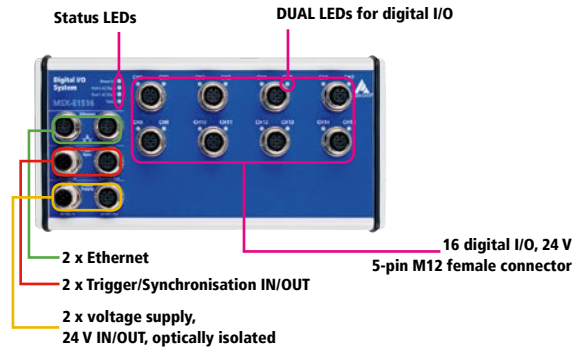

Simplified block diagram

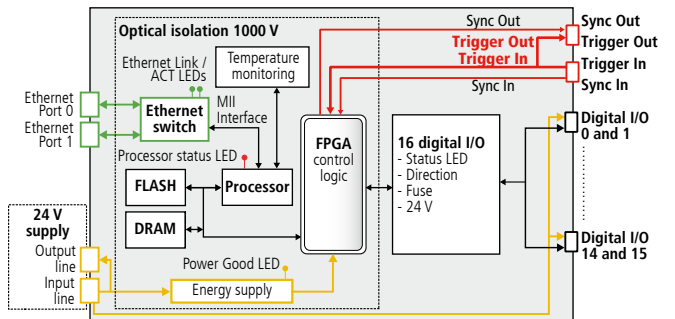

Cascading

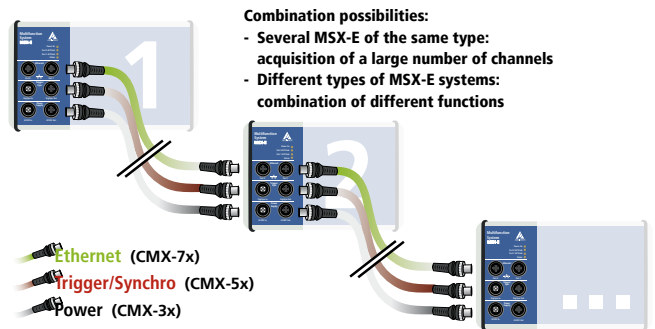

- Combination possibilities:**
- Several MSX-E of the same type: acquisition of a large number of channels
 - Different types of MSX-E systems: combination of different functions

ADDI-DATA connection technology

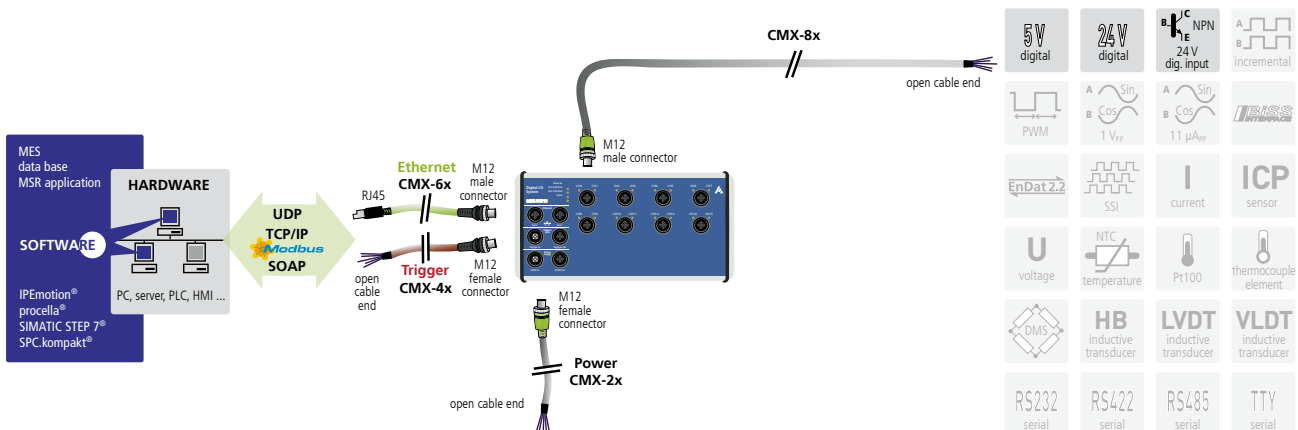

* Preliminary product information

Specifications*

Digital inputs

Number of inputs:	16, 2 per M12 female connector Common ground acc. to IEC 1131-2
Overvoltage protection:	30 V
Optical isolation:	1000 V through opto-couplers
Nominal voltage:	24 VDC
Input voltage:	0 to 30 V
Input impedance:	> 1 MΩ
Logic input levels:	UH (max) 30 V typ. UH (min) 18 V typ. UL (max) 16 V typ. UL (min) 0 V typ.

Digital outputs

Number of outputs:	16, 2 per M12 female connector
Optical isolation:	1000 V through opto-couplers
Output type:	High-side, load to ground acc. to IEC 1131-2
Nominal voltage:	24 V
Voltage supply:	18 V-30 V
Current (max.):	1.85 A typ. for 8 channels through PTC at 20°C
Output current per channel:	500 mA max. Short-circuit current per output 1.7 A max Shut-down logic at 24 V, $R_{load} = 10\text{ m}\Omega$
RDS ON Resistance:	280 mΩ max.
Switch-on time:	100 μs max RL = 48 Ω of 80 % V_{out}
Switch-off time:	150 μs max RL = 48 Ω of 10 % V_{out}
Overtemperature (shutdown):	135°C max. (output driver)
Temperature hysteresis:	15°C typ. (output driver)
Diagnostics:	Common diagnostics bit for all 16 channels at overtemperature of one channel

Voltage supply, Ethernet, Trigger, Synchro

The specifications for the voltage supply, Ethernet, Trigger, Synchronisation and Electromagnetic Compatibility apply to all MSX-E systems. See page 27.

System features

Interface:	Ethernet acc. to specification IEEE802.3
Dimensions:	215 mm x 110 mm x 50 mm
Weight:	900 g
Degree of protection:	IP 65
Current consumption at 24 V:	160 mA
Operating temperature:	-40 °C to +85 °C
Connectors for sensors	
For digital I/O:	8 x 5-pin M12 female connector

Ordering information

MSX-E1516, MSX-E1516-NPN

Ethernet digital I/O system, 16 digital I/O, 24 V, with event logic. Incl. technical description, software drivers and ConfigTools.

Versions

MSX-E1516:	16 digital I/O, 24 V
MSX-E1516-NPN:	16 digital inputs, 24 V (NPN)

Connection cables

Voltage supply

CMX-2x: Shielded cable, M12 5-pin female connector/open end, IP 65

CMX-3x: For cascading, shielded cable, M12 5-pin female connector/male connector IP 65

Trigger/Synchro

CMX-4x: Shielded cable, M12 5-pin female connector/open end, IP 65

CMX-5x: For cascading, shielded cable, M12 5-pin female connector/male connector IP 65

Ethernet

CMX-6x: CAT5E cable, M12 D-coded male connector/RJ45 connector

CMX-7x: For cascading, CAT5E cable, 2 x M12 D-coded male connector

Connection to peripherals

CMX-8x: Shielded cable, M12 5-pin male connector/open end, IP 65

Options

S7 Modbus TCP Client Library for S7: Easy use of the Ethernet systems MSX-E with PLCs

MSX-E 5V-Trigger: Level change of the trigger inputs and outputs to 5 V

MX-Clip, MX-Rail (please specify when ordering!),

MX-Screw, PCMX-1x

*Preliminary product information