

V1151

Quad-Port 10/25/40/100G FPGA XMC Card

Benefits

High density FPGA XMC card for next generation data distribution and signal intelligence systems

Supports 1/10/25G Ethernet, 1/2/4/16/32G Fibre Channel, 1/2/2.5/10G sFPDP

A COTS solution optimized for SWaP (size, weight and power)

Next generation host interface connection bandwidths

A programmable FPGA with a powerful development framework

Real time data streaming directly from sensors

Features

Four SFP28 ports accommodate either:

- 1x 100G Ethernet
- 1x 40G Ethernet
- 4x 25G Ethernet
- 4x 10G Ethernet
- 4x 1G Ethernet
- 4x 1/2/4/8/16/32G Fibre Channel
- 4x 1/2/2.5/10G sFPDP

Xilinx Virtex/Kintex Ultrascale+ FPGA

Supports PCIe Gen3 x 16 and Gen4 x 8

PPS time synch μ Sec resolution

Thermal sensors for monitoring card temperature

Robust FPGA development framework

Advanced APIs that support multi-core and multi-processor architectures

Optimized VxWork and Linux drivers and libraries

UDP offload engine for real-time communication

Streaming front-end FPGA core for quick sensor integration

Available in air and conduction-cooled XMC form factors

Overview

Reducing system size, weight and power (SWaP), while increasing performance, is critical for operational life and budgetary constraints of military radar and remote sensing systems. The requirement for increasingly higher port density, bandwidth, and processing power to support larger arrays, while still staying within SWaP and budget requirements, is a significant challenge to engineering architects. New Wave DV satisfies these requirements with the V1151 1/10/25/40/100 Gigabit Ethernet XMC Card — dramatically increasing bandwidth while providing plenty of FPGA resources to process data and support PCIe host connectivity.

Increased Bandwidth & Flexibility

The V1151 is the industry's most advanced XMC solution designed to provide a real-time high-bandwidth network interface and processing module for next generation radar and signal intelligence systems. It comes with a range of Xilinx Virtex/Kintex UltraScale+ FPGAs, different memory configurations to meet application requirements, and support for different carrier boards using PCIe and XAUI. Design flexibility to meet application requirements results in optimized SWaP, shorter development cycle, and enhanced performance.



V1151

Quad-Port 10/25/40/100G FPGA XMC Card

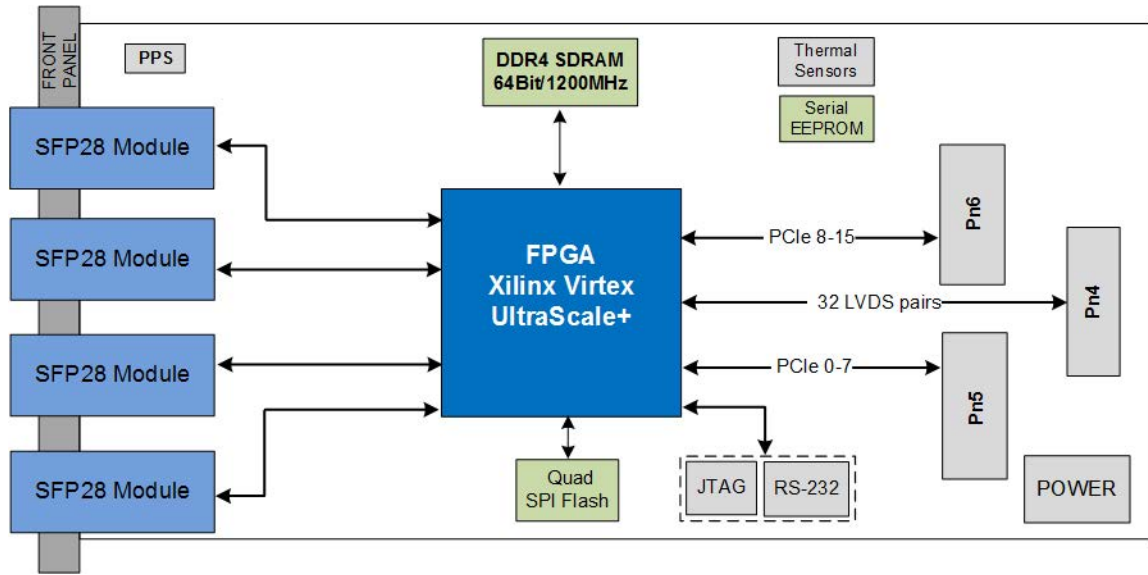

> V1151 XMC Card Block Diagram

Simplified Programmability Framework

The V1151 ships with the expressXG Development Framework, a fully integrated and flexible toolset that provides the infrastructure necessary to ensure rapid deployment of applications. The framework abstracts the details of Ethernet/Fibre Channel protocols and interfaces, memory controllers and host fabric interfaces, thereby reducing the development effort and schedule for designers to implement custom solutions. High performance software libraries and drivers ensure that the card is running “out of the box.”

Multi-processor Multi-core Support

The V1151 is uniquely suited to system architectures involving multiple processing cards on a common switched data plane. Specifically, the V1151 supports shared access from multiple host processors, enabling it to function as a cost effective, high-performance gateway. This feature enables a single high-speed pipe to carry multiple virtual channels in systems that need to spread or load balance sensor data across processor farms.

Optional Offload Engines

The V1151 has built-in support for UDP, ARP and ICMP communication protocols. When used as a gateway, the V1151 supports PCI Express over the Pn5 (and optionally Pn6) connector for processor communication and comes with high level APIs for control and data transfer resulting in a simplified programming model.

Operation Customization

The V1151 is an FPGA based network card that can be customized to fit your requirements. New Wave provides access to the FPGA for customers to customize, however New Wave can also modify existing cores or develop new cores for your applications. If you have specific networking requirements, New Wave can help you accomplish your goals.

V1151

Quad-Port 10/25/40/100G FPGA XMC Card

Complete Product Support Program

New Wave DV prides itself on its excellent customer support, a fact that is echoed by our customers. New Wave DV provides industry standard warranty on its products, but it is the human factor that makes our support so valuable to our customers. Our team takes the time and effort to ensure that the customer experience with our products is a positive one.

Our Commitment

New Wave DV is committed to providing the latest innovations in technology, architectures, and techniques to keep our customers one step ahead of the rest. Our products, complete with expressXG Development Framework, are intended to offer our customers an entirely unique out-of-the-box experience.

Ordering Information

300-01151-00-00: V1151 XMC Network Card, Virtex UltraScale+ VU5P, Air Cooled

Other product configurations are available. Please contact us.

Technical Specifications

NETWORK INTERFACE

Four SFP28 optical ports

ETHERNET PROTOCOLS

TCP, UDP, ARP, ICMP, Multicast, Broadcast

FIBRE CHANNEL PROTOCOLS

RDMA, ASM

ADDITIONAL PROTOCOLS

sFPDP

FPGA DEVICE

Xilinx Virtex UltraScale+ (VU3P)

Xilinx Virtex UltraScale (VU065-VU095)

Xilinx Kintex UltraScale (KU095)

MEMORY

One bank of 4GB to 16GB 64-bit up to 1200MHz DDR4 SDRAM

FLASH

One 1Gb memory for storing a default configuration image

HOST INTERFACE

PCI Express (Gen4) x8 (Pn5)

PCI Express (Gen3) x16 (Pn5 & Pn6)

Two XAUI (Pn5), Two XAUI (Pn6)

EXTERNAL INTERFACE

32 differential pairs (user configurable)

PPS Interface for time synchronization with μ second

resolution RS-232 serial interface for debug

THERMAL SENSORS

2 digital temperature sensors

COMPLIANCE

VITA 42.2, 42.3, 42.6

VITA 61.0

IEEE 802.3ae 2002 IEEE

802.3ba 2010

FC-FS-3 INCITS 470-2011

DIMENSIONS

74 mm (width) x 149 mm (length)

POWER REQUIREMENTS

Maximum 25W (preliminary)

TEMPERATURE

Operating: 0° C to 45° C at 600 LFM (air cooled)

Operating: -40° C to 70° C (conduction cooled)

Storage: -40° C to 85° C

FOR MORE INFORMATION

www.newwavedv.com
info@newwavedv.com
Phone +1 952-224-9201

New Wave DV
4950 W 78th St. Minneapolis,
MN 55416 USA

