

5

TECHNOLOGY  
TRENDS  
THAT  
CHANGE THE GAME

**PLUS:**

ATCA and CompactPCI Find Their  
Military System Niches

Ethernet and Other Links Feed  
Rising Sensor Bandwidth Demands

# 10 GbE Digital Recording Feeds Demands from Wideband Sensors

As sensor speed and accuracy increase, demand for high-bandwidth acquisition and recording of incoming signals is ramping up fast. Ethernet interfaces help keep pace with the avalanche of incoming data.

Rodger Hosking, Vice President  
Pentek

Acquisition and recording of signals from sensors occurs on virtually all commercial, government and military systems for aircraft, ships and manned and unmanned vehicles. Similar technology abounds in manufacturing, medical and testing operations. Often scattered at various remote locations, these sensors require secure links back to the acquisition system. To avoid signal degradation over long distances, traditional analog sensors are often coupled to local digitizers to support digital transmission back to the system. The latest sensors are not only faster and more accurate, but most now feature integrated digital interfaces.

As the quantity and speed of these sensors increase, so do the demands on the recording system. With that in mind, it's helpful to look at how high-bandwidth remote sensors can be configured for transmitting the data and how new recorder architectures can support the steadily increasing data rates to ensure real-time performance.

### Distributed Sensor Subsystems

Some sensors measure physical properties with low information bandwidth, such as pressure, position or tem-



Figure 1

Northrop Grumman's APG-81 active electronically scanned array (AESA) radar has been tested by successfully tracking long-range targets as part of the mission systems test flights of Lockheed Martin's F-35 Lightning II BF-4 aircraft.

perature, with only a few readings per second. Others require bandwidths up to 100 kHz or more, such as transducers for sonar, acoustics, shock and vibration. Video sensors and HF radio frequency antennas might boost the required sam-

ple rate upwards to 100 MHz. Rapidly advancing A/D converter technology gives us monolithic devices suitable for digitizing much higher frequency radio signals for wideband communications and radar system. At the high end, the new Texas Instruments ADC12D1800 A/D delivers 12-bit samples at 3.6 GHz, generating a data stream at an impressive rate of 5.4 Gbytes/s.

To make matters even more challenging, these wideband systems often use multi-element antenna arrays. A linear array might consist of multiple antennas distributed along the length of a ship for a directional diversity receiver. Two-dimensional arrays of adjacent elements making up a SAR radar antenna are installed on the outside surfaces of military aircraft (Figure 1). Each antenna signal must be conditioned and digitized for delivery to the required software defined radio signal processing and recording system tailored to each application.

### Moving Processing Up Front

As mentioned earlier, these signals are digitized as close to the antenna as possible to maintain signal fidelity. Another objective of signal processing near the antenna is to reduce the required

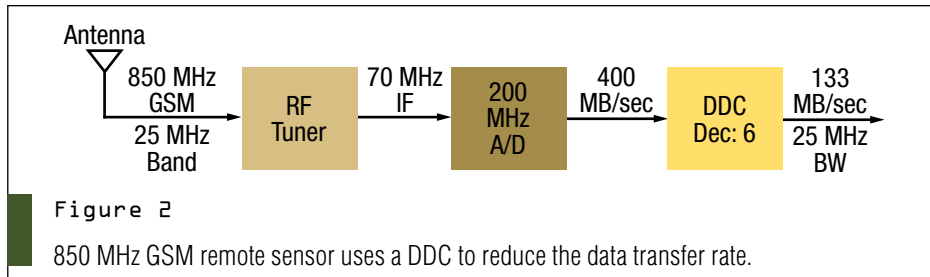

transmission data rate. This yields two immediate benefits: it eases traffic on the digital link to the recording system, and it reduces the maximum recorder data rate. To achieve this data rate reduction, digital downconverters (DDCs) take advantage of the fact that signals of interest for radar and communications are usually located within a certain frequency band.

For example, the 850 MHz GSM band used for mobile telecom has two allocated 25 MHz bands, one for uplink at 824-849 MHz and one for downlink at 869-894 MHz. Signals outside of these two bands are generally of no interest to an acquisition and recording system intended for GSM signals, so there is no benefit in capturing unwanted out-of-band information. In this case, the sensor acquisition system would typically translate these two 25 MHz RF bands down to an IF frequency using an analog RF tuner. By dropping these frequency bands to a center frequency of 70 MHz for example, the signals of interest fall between 57.5 and 82.5 MHz, ideal for a 16-bit A/D converter operating at 200 MHz sample rate.

The A/D output sample stream feeds the DDC, which contains a digital mixer, digital local oscillator and digital low pass filter. The DDC further translates the 25 MHz band down to baseband (0 Hz) and delivers a bandlimited, complex (I+Q) digital output at a decimated sample rate of 33.3 MHz, or 133 Mbytes/s. This results in a 66 percent reduction in the 400 Mbyte/s data rate at the A/D output, yet preserves all of the required signal information bandwidth. This signal sensor

front end, shown in Figure 2, must deliver this stream through a link to the recording system.

## 10 Gigabit Ethernet

Older high-speed digital cable interfaces using parallel differential copper pairs over flat ribbon cable or multi-conductor round cable suffer from bandwidth limitations, expensive connectors, expensive assembly, bulky size and signal degradation over even moderate distances. Over the last decade, several new gigabit serial standards have emerged and matured into mainstream high-speed digital interconnection strategies. The most popular are 1 Gbit Ethernet, and 10 Gbit Ethernet, both driven down in cost by widespread, high-volume IT and network applications. The system software transparency of these two standards from legacy 10 and 100 Mb Ethernet ensured immediate adoption as soon as they became affordable.

Ethernet was not originally well-suited for transmission of real-time signals because of non-deterministic latency, 8B10B channel coding (adding 25 percent overhead), and reliance on system processors to manage the stack. However, the new 10 GbE standard radically changes the landscape. It is inherently fast because of its higher bit clock rate, it has more efficient 64B66B channel coding, as well as dedicated hardware engines for protocol processing. All of these benefits make 10 GbE suitable for moving data up to 1 Gbytes/s.

Standardization of copper and optical connectors and cables for 10 GbE have

eased system integration tasks with most systems using the SFP+ (small form-factor pluggable) modules that incorporate interface circuitry and connectors. Maximum cable length depends on the interface: about 15m for Twinax copper, 300m for multi-mode optical fiber, and 10 km for single-mode optical fiber.

Imagine a 12-channel GSM recorder system requirement, where each channel digitizes the antenna signal and down-converts it to the 133 Mbyte/s stream described earlier. Six streams yield a combined data rate of 800 Mbyte/s, well-suited to the 1 Gbyte/s capacity of a single 10 GbE link shown in Figure 3. Thus, a 12-channel recorder could use two of these remote, 6-channel sensor subsystems delivering data through two 10 GbE links. The recorder would need to store this data at an aggregate rate of 1.6 Gbytes/s, about 16 times faster than a typical single hard drive.

## High-Speed Recorder Hardware

Fortunately, recording rates of over 2 Gbytes/s in a single chassis are now achievable by judiciously combining the latest technology available in high-performance server-class PCs, I/O adapters, RAID controllers, and disk drives. The most significant major performance boost in embedded systems and servers is the widespread adoption of PCIe links between system elements, replacing the much slower PCI and PCI-X parallel buses. Instead of sharing a single parallel bus with sequential read or write operations for one board at a time, full-duplex serial PCIe links join each slot to a switch, supporting simultaneous reads and writes on each board. And PCIe links outperform PCI-X in raw speed: a 64-bit PCI-X bus at 133 MHz moves data in one direction at a peak rate of 1 Gbytes/s, while a PCIe x16 Gen2 link performs simultaneous reads and writes, each at 8 Gbytes/s.

New I/O boards take full advantage of PCIe to eliminate system bottlenecks.

Because a two-channel 10 GbE host bus adapter board must handle two 1 Gbyte/s streams, choosing a PCIe x8 Gen2 interface provides comfortable headroom with 4 Gbyte/s throughput. Likewise, the latest RAID controller boards use motherboard PCIe x8 Gen2 ports to handle faster disk drives with their new 6 Gbyte/s SATA-III interfaces. Although rotating media hard drives now offer capacities of 2 Tbytes or more, solid state drives (SSDs) are quickly gaining ground with capacities exceeding 500 Mbytes. More important for high-speed recorders, SSDs now deliver read/write rates of over 400 Mbytes/s, a fourfold increase over rotating drives.

When connected to a high-performance PCIe RAID controller, multiple SSDs can be aggregated in speed and capacity to achieve overall transfer rates of 1.2 Gbytes/s for a six-drive array. For our 12-channel GSM system shown in Figure 4, two of these RAID arrays can easily handle both 10 GbE streams. Finally, data streams joining all of these hardware components must be artfully managed by controlling software.

### High-Speed Recorder Software

The big challenge for embedded system recorders is keeping the software away from the data. If the processor is responsible for moving data between sys-

tem resources, high-speed sustained rates are hard to guarantee, even when running under a real-time multitasking operating system. One successful strategy enlists hardware DMA controllers to conduct all real-time data transfers. These dedicated engines can be programmed with source and destination addresses, transfer block lengths and configurable interrupts for starting and stopping. Instead of touching the data, the system processor simply orchestrates DMA operations, keeping track of real-time block transfers as they occur through interrupts.

DMA controllers on the I/O boards move data from the 10 GbE streams into blocks of system memory, and DMA con-

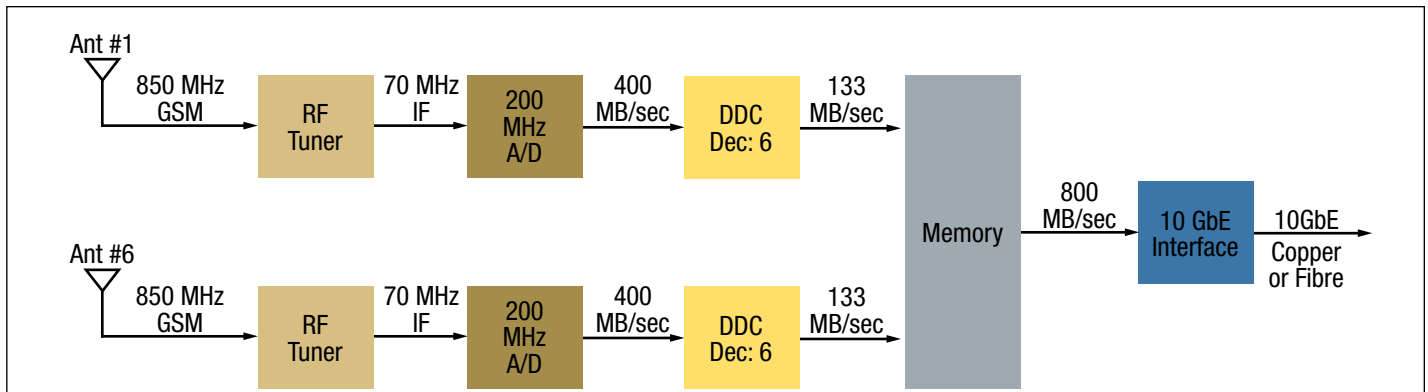

Figure 3 Six-channel 850 MHz GSM remote sensor subsystem with 10 GbE interface.

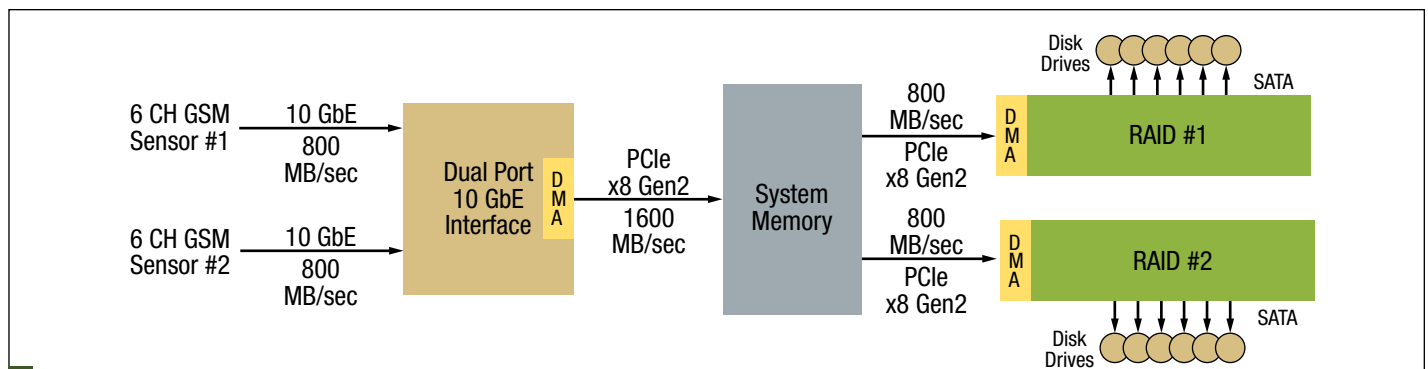

Figure 4 The RTS 2715 12-channel GSM recorder accepts dual 10 GbE links. SystemFlow software uses PCIe links and hardware DMA controllers move data at rates up to 2 Gbytes/s.



Figure 5

The RTS 2715 Dual 10 GbE recorder is accommodated in a 4U or 5U rackmount chassis.

trollers on the RAID boards move data from system memory onto the disks. Careful calculation of the size and number of system memory blocks is based on the data transfer rates and buffer characteristics of each board. The optimal solution maximizes throughput and ensures zero loss of data.

Pentek offers its SystemFlow recording software, which incorporates all of these high-speed recording strategies. Built using a client/server architecture, all real-time server operations

are handled with hardware DMA data transfers that are independent of the operating system activity. This allows hard real-time performance when running under the Windows 7 operating system. One major benefit is that all recorded files use the NTFS file format so they may be opened immediately after recording by any Windows application. SystemFlow presents a ready-to-use virtual instrument GUI control panel client with intuitive push buttons and text entry windows for file names and recording parameters. An API allows users to connect directly to the server as a controllable record/playback subsystem and as a front end to a larger application system.

### Putting It All Together

The RTS 2715 Dual 10 GbE recorder shown earlier is accommodated in a 4U or 5U rackmount chassis like the one shown in Figure 5. The system accepts two 10 GbE streams over copper CX4 cables, or alternatively, multi-mode or single-mode LC optical cables. An optional GPS receiver allows time and location stamping of the recorded data files.

Two types of disk drives are available. SSDs are used for rugged environments because of their inherent resistance to shock and vibration. A 12-drive dual 10 GbE SSD system can store 3 Terabytes of data for sustained recording of more than 30 minutes at 1600 Mbytes/s. For laboratory environments, larger rotating media drives are available. A 24-drive dual channel system with 20 TB or storage can record continuously for more than 200 minutes.

Distributed wideband sensors for recording systems are well-matched to 10 GbE, currently the fastest and most popular network standard. High-performance embedded computers will continue to benefit from PC and IT market forces for fast board-to-board links, higher-capacity and faster disk drives, and advances in silicon technology. Recording software must be carefully crafted to take best speed advantage of this powerful hardware. ■■

*Pentek  
Upper Saddle River, NJ.  
(201) 818-5900.  
[www.pentek.com].*

# Critical Recording in Any Arena

## When You Can't Afford to Miss a Beat!



Introducing Pentek's expanded line of Talon™ COTS, rugged, portable and lab-based recorders. Built to capture wideband SIGINT, radar and communication signals right out-of-the-box:

- Analog RF/IF, 10 GbE, LVDS, sFPDP solutions
- Real-time sustained recording to 2.2 GB/sec
- Recording and playback operation
- Analog signal bandwidths to 1 GHz
- Shock and vibration resistant Solid State Drives
- GPS time and position stamping
- Hot-swappable storage to Windows® NTFS RAIDs
- Remote operation & multi-system synchronization
- SystemFlow® API & GUI with Signal Analyzer
- Complete documentation & lifetime support

Pentek's rugged turn-key recorders are built and tested for fast, reliable and secure operation in your environment.

Call 201-818-5900 or go to [www.pentek.com/go/cotstalon](http://www.pentek.com/go/cotstalon) for your FREE online *High-Speed Recording Systems Handbook* and *Talon Recording Systems Catalog*.



**PENTEK**  
Setting the Standard for Digital Signal Processing

