



Putting FPGAs to Work in Software Radio Systems

Seventh Edition

Technology
FPGA Resources
Products
Applications
Links

by

Rodger H. Hosking

Vice-President & Cofounder of Pentek, Inc.

Pentek, Inc.

One Park Way, Upper Saddle River, New Jersey 07458

Tel: (201) 818-5900 • Fax: (201) 818-5904

Email: info@pentek.com • <http://www.pentek.com>

Copyright © 2005, 2007, 2008, 2009, 2010, 2011, 2012, 2013 Pentek, Inc.

Last Updated: November 2013

All rights reserved.

Contents of this publication may not be reproduced in any form without written permission.
Specifications are subject to change without notice.

Pentek, GateFlow, ReadyFlow, SystemFlow and Cobalt are registered trademarks of Pentek, Inc.

Preface

FPGAs have become an increasingly important resource for software radio systems. Programmable logic technology now offers significant advantages for implementing software radio functions such as DDCs (Digital Downconverters). Over the past few years, the functions associated with DDCs have seen a shift from being delivered in ASICs (Application-Specific ICs) to operating as IP (Intellectual Property) in FPGAs.

For many applications, this implementation shift brings advantages that include design flexibility, higher precision processing, higher channel density, lower power, and lower cost per channel. With the advent of each new, higher-performance FPGA family, these benefits continue to increase.

This handbook introduces the basics of FPGA technology and its relationship to SDR (Software Defined Radio) systems. A review of Pentek's GateFlow FPGA Design Resources is followed by a discussion of features and benefits of FPGA-based DDCs. Pentek SDR products that utilize FPGA technology and applications based on such products are also presented.

*For a more in-depth discussion of SDR systems, the reader is referred to Pentek's **Software Defined Radio Handbook***

For more information on complementary subjects, the reader is referred to these Pentek Handbooks:

Critical Techniques for High-Speed A/D Converters in Real-Time Systems

High-Speed Switched Serial Fabrics Improve System Design

High-Speed, Real-Time Recording Systems

Technology

Typical Software Radio System

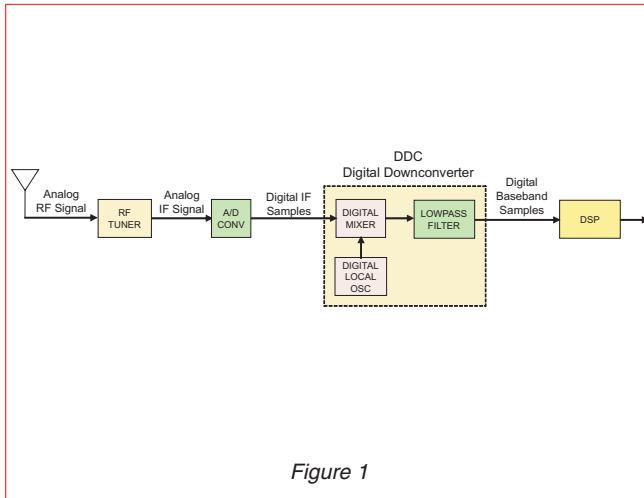

We begin our discussion with the basic elements of a software radio receiver system.

The front end usually contains an analog RF amplifier and often an analog RF translator. This translates the high frequency RF signals down to a frequency that an A/D converter can handle. This is usually below 200 MHz and is often an IF output.

The A/D output feeds the DDC (Digital Downconverter) stage, which is typically contained in a monolithic chip which forms the heart of a software radio system.

Notice, that after the signal is digitized by the A/D converter, all further operations are performed by digital signal-processing hardware.

Software Radio Tasks

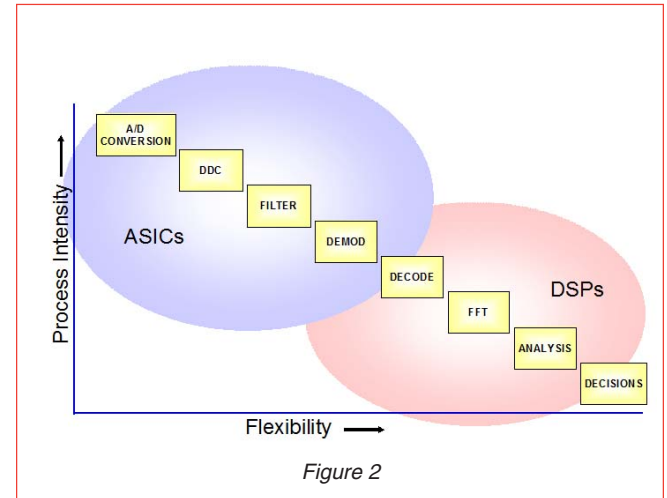

Here we've ranked some of the popular signal-processing tasks associated with SDR systems on a two axis graph, with compute Processing Intensity on the vertical axis and Flexibility on the horizontal axis.

What we mean by process intensity is the degree of highly-repetitive and rather primitive operations. At the upper left are dedicated functions like A/D converters and DDCs that require specialized hardware structures to complete the operations in real time. ASICs are usually chosen for these functions.

Flexibility pertains to the uniqueness or variability of the processing and how likely the function may have to be changed or customized for any specific application. At the lower right are tasks like analysis and decision-making which are highly variable and often subjective.

Programmable general-purpose processors or DSPs are usually chosen for these tasks since these tasks can be easily changed by software.

Now let's temporarily step away from the software radio tasks and take a deeper look at programmable logic devices.

Technology

Early Roles for FPGAs

- Used primarily to replace discrete digital hardware circuitry for:
 - Control logic
 - Glue logic
 - Registers and gates
 - State machines
 - Counters and dividers
- Devices were selected by hardware engineers
- Programmed functions were seldom changed after the design went into production

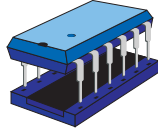

Figure 3

As true programmable gate functions became available in the 1970's, they were used extensively by hardware engineers to replace control logic, registers, gates and state machines which otherwise would have required many discrete, dedicated ICs.

Often these programmable logic devices were one-time factory-programmed parts that were soldered down and never changed after the design went into production.

Legacy FPGA Design Methodologies

- Tools were oriented to hardware engineers
 - Schematic processors
 - Boolean processors
 - Gates, registers, counters, multipliers
- Successful designs required high-level hardware engineering skills for:
 - Critical paths and propagation delays
 - Pin assignment and pin locking
 - Signal loading and drive capabilities
 - Clock distribution
 - Input signal synchronization and skew analysis



Figure 4

These programmable logic devices were mostly the domain of hardware engineers and the software tools were tailored to meet their needs. You had tools for accepting boolean equations or even schematics to help generate the interconnect pattern for the growing number of gates.

Then, programmable logic vendors started offering predefined logic blocks for flip-flops, registers and counters, that gave the engineer a leg up on popular hardware functions.

Nevertheless, the hardware engineer was still intimately involved with testing and evaluating the design using the same skills he needed for testing discrete logic designs. He had to worry about propagation delays, loading, clocking and synchronizing—all tricky problems that usually had to be solved the hard way—with oscilloscopes or logic analyzers.

Technology

FPGAs: New Device Technology

- ◆ 500+ MHz DSP slices and memory structures
- ◆ Over 3500 dedicated on-chip hardware multipliers
- ◆ On-board GHz serial transceivers
- ◆ Partial reconfigurability maintains operation during changes
- ◆ Switched fabric interface engines
- ◆ Over 690,000 logic cells
- ◆ Gigabit Ethernet media access controllers
- ◆ On-chip 405 PowerPC RISC microcontroller cores
- ◆ Memory densities approaching 85 million bits
- ◆ Reduced power with core voltages at 1 volt
- ◆ Silicon geometries to 28 nanometers
- ◆ High-density BGA and flip-chip packaging
- ◆ Over 1200 user I/O pins
- ◆ Configurable logic and I/O interface standards



Figure 5

It's virtually impossible to keep up to date on FPGA technology, since new advancements are being made every day.

The hottest features are processor cores inside the chip, computation clocks to 500 MHz and above, and lower core voltages to keep power and heat down.

Several years ago, dedicated hardware multipliers started appearing and now you'll find literally thousands of them on-chip as part of the DSP initiative launched by virtually all FPGA vendors.

High memory densities coupled with very flexible memory structures meet a wide range of data flow strategies. Logic slices with the equivalent of over ten million gates result from silicon geometries shrinking below 0.1 micron.

BGA and flip-chip packages provide plenty of I/O pins to support on-board gigabit serial transceivers and other user-configurable system interfaces.

New announcements seem to be coming out every day from chip vendors like Xilinx and Altera in a never-ending game of outperforming the competition.

FPGAs: New Development Tools

- High Level Design Tools
 - Block Diagram System Generators
 - Schematic Processors
 - High-level language compilers for VHDL & Verilog
 - Advanced simulation tools for modeling speed, propagation delays, skew and board layout
 - Faster compilers and simulators save time
 - Graphically-oriented debugging tools
- IP (Intellectual Property) Cores
 - FPGA vendors offer both free and licensed cores
 - FPGA vendors promote third party core vendors
 - Wide range of IP cores available



Figure 6

To support such powerful devices, new design tools are appearing that now open up FPGAs to both hardware and software engineers. Instead of just accepting logic equations and schematics, these new tools accept entire block diagrams as well as VHDL and Verilog definitions.

Choosing the best FPGA vendor often hinges heavily on the quality of the design tools available to support the parts.

Excellent simulation and modeling tools help to quickly analyze worst case propagation delays and suggest alternate routing strategies to minimize them within the part. This minimizes some of the tricky timing work for hardware engineers and can save one hours of tedious troubleshooting during design verification and production testing.

In the last few years, a new industry of third party IP (Intellectual Property) core vendors now offer thousands of application-specific algorithms. These are ready to drop into the FPGA design process to help beat the time-to-market crunch and to minimize risk.

Technology

FPGAs for SDR

- Parallel Processing
- Hardware Multipliers for DSP
 - FPGAs can now have over 500 hardware multipliers
- Flexible Memory Structures
 - Dual port RAM, FIFOs, shift registers, look up tables, etc.
- Parallel and Pipelined Data Flow
 - Systolic simultaneous data movement
- Flexible I/O
 - Supports a variety of devices, buses and interface standards
- High Speed
- Available IP cores optimized for special functions



Figure 7

Like ASICs, all the logic elements in FPGAs can execute in parallel. This includes the hardware multipliers, and you can now get over 3500 of them on a single FPGA.

This is in sharp contrast to programmable DSPs, which normally have just a handful of multipliers that must be operated sequentially.

FPGA memory can now be configured with the design tool to implement just the right structure for tasks that include dual port RAM, FIFOs, shift registers and other popular memory types.

These memories can be distributed along the signal path or interspersed with the multipliers and math blocks, so that the whole signal processing task operates in parallel in a systolic pipelined fashion.

Again, this is dramatically different from sequential execution and data fetches from external memory as in a programmable DSP.

As we said, FPGAs now have specialized serial and parallel interfaces to match requirements for high-speed peripherals and buses.

FPGAs Bridge the SDR Application Task Space

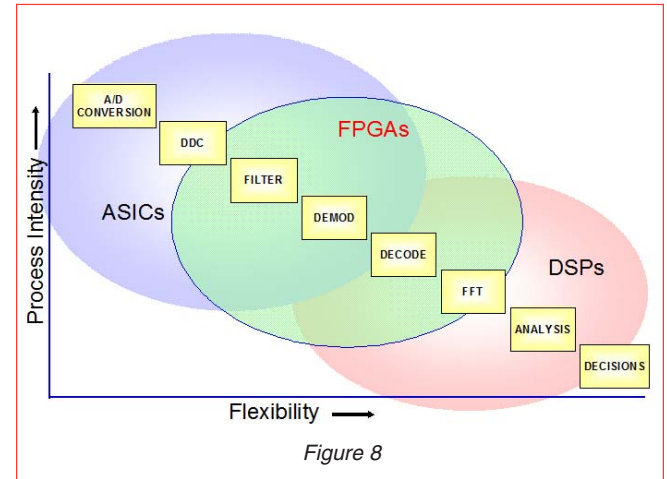

Figure 8

As a result, FPGAs have significantly invaded the application task space as shown by the center bubble in the task diagram above.

They offer the advantages of parallel hardware to handle some of the high process intensity functions like DDCs and the benefit of programmability to accommodate some of the decoding and analysis functions of DSPs.

These advantages may come at the expense of increased power dissipation and increased product costs. However, these considerations are often secondary to the performance and capabilities of these remarkable devices.

FPGA Resources

FPGA Resource Comparison

	Virtex-II Pro VP	Virtex-4 FX, LX, SX	Virtex-5 LX, SX	Virtex-6 LX, SX	Virtex-7 VX
Logic Cells	53K–74K	55K–110K	52K–155K	128K–314K	326K–693K
Slices*	23K–33K	24K–49K	8K–24K	20K–49K	51K–108K
CLB Flip-Flops	46K–66K	48K–98K	32K–96K	160K–392K	408K–864K
Block RAM (kb)	4,176–5,904	4,176–6,768	4,752–8,784	9,504–25,344	27,000–52,920
DSP Hard IP	18x18 Multipliers	DSP48	DSP48E	DSP48E	DSP48E
DSP Slices	232–328	96–512	128–640	480–1,344	1,120–3,600
Serial Gbit Transceivers	N/A	0–20	12–16	20–24	28–80
PCI Express Support	N/A	N/A	N/A	Gen 2 x8	Gen 2 x8, Gen 3 x8
User I/O	852–996	576–960	480–680	600–720	700–1,000

*Virtex-II Pro and Virtex-4 Slices actually represent 2.25 Logic Cells;
*Virtex-5, Virtex-6 and Virtex-7 Slices actually represent 6.4 Logic Cells

Figure 9

The above chart compares the available resources in the five Xilinx FPGA families that are used in most of the Pentek products.

- Virtex-II Pro: VP
- Virtex-4: FX, LX and SX
- Virtex-5: LX and SX
- Virtex-6: LX and SX
- Virtex-7: VX

The Virtex-II family includes hardware multipliers that support digital filters, averagers, demodulators and FFTs—a major benefit for software radio signal processing. The Virtex-II Pro family dramatically increased the number of hardware multipliers and also added embedded PowerPC microcontrollers.

The Virtex-4 family is offered as three subfamilies that dramatically boost clock speeds and reduce power dissipation over previous generations.

The Virtex-4 LX family delivers maximum logic and I/O pins while the SX family boasts of 512 DSP slices for maximum DSP performance. The FX family is a generous mix of all resources and is the only family to offer RocketIO, PowerPC cores, and the newly added gigabit Ethernet ports.

The Virtex-5 family LX devices offer maximum logic resources, gigabit serial transceivers, and Ethernet media access controllers. The SX devices push DSP capabilities with all of the same extras as the LX.

The Virtex-5 devices offer lower power dissipation, faster clock speeds and enhanced logic slices. They also improve the clocking features to handle faster memory and gigabit interfaces. They support faster single-ended and differential parallel I/O buses to handle faster peripheral devices.

The Virtex-6 and Virtex-7 devices offer still higher density, more processing power, lower power consumption, and updated interface features to match the latest technology I/O requirements including PCI Express. Virtex-6 supports PCIe 2.0 and Virtex-7 supports PCIe 3.0

The ample DSP slices are responsible for the majority of the processing power of the Virtex-6 and Virtex-7 families. Increases in operating speed from 500 MHz in V-4, to 550 MHz in V-5, to 600 MHz in V-6, to 900 MHz in V-7 and continuously increasing density allow more DSP slices to be included in the same-size package. As shown in the chart, Virtex-6 tops out at an impressive 1,344 DSP slices, while Virtex-7 tops out at an even more impressive 3,600 DSP slices.

FPGA Resources

GateFlow FPGA Design Resources

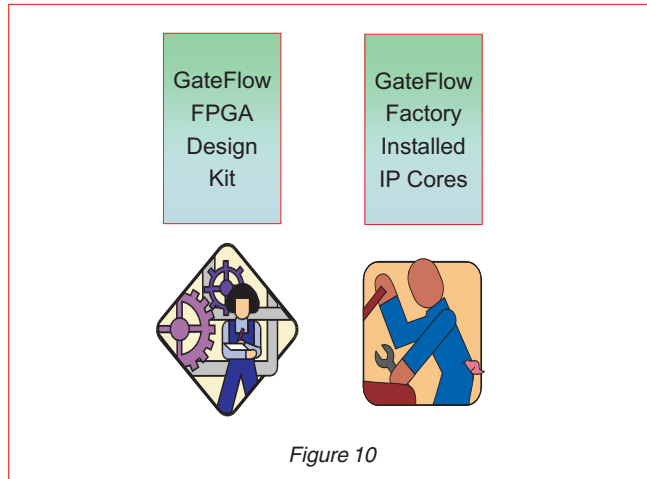

GateFlow® is Pentek’s flagship collection of FPGA Design Resources. The GateFlow line is compatible with the Xilinx Virtex products and is available as two separate offerings:

If you want to add your own custom algorithms, we offer the GateFlow FPGA Design Kit.

We also offer popular high-performance signal-processing algorithms with the GateFlow factory-installed IP Cores. These algorithms are designed and optimized expressly for Xilinx FPGAs and Pentek hardware products.

Installed Cores are delivered to you preinstalled in your Pentek FPGA-based product of choice and are fully supported with Pentek ReadyFlow® Board Support Packages.

Let’s start with the GateFlow FPGA Design Kit.



GateFlow FPGA Design Kit

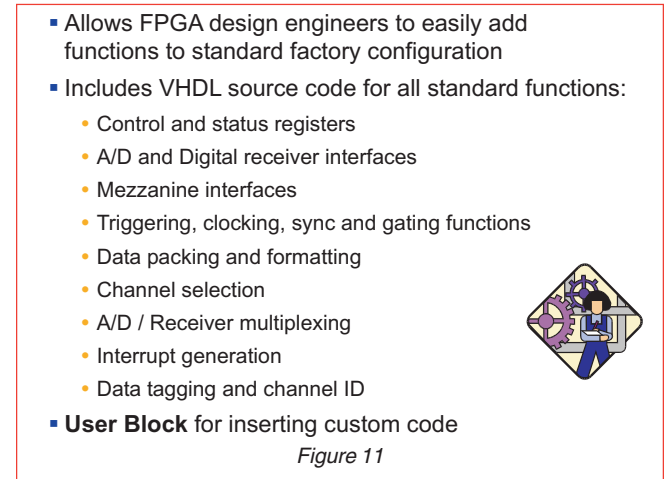

If you want to add your own algorithms to Pentek catalog products, we offer the GateFlow FPGA Design Kit that includes VHDL source code for all the standard factory functions.

VHDL is one of the most popular languages used in the FPGA design tools. The GateFlow Design Kit includes the VHDL source code for every software module we use to create these standard factory features of the product.

The standard factory configuration supports a wide range of operating modes, timing and sync functions, as well as several different data formatting options.

This includes control and status registers, peripheral interfaces, mezzanine interfaces, timing functions, data formatting, channel selection, interrupt support, and data tagging.

These are also fully supported with our ReadyFlow Board Support Package.

FPGA Resources

GateFlow FPGA Design Kit for Cobalt or Onyx Products

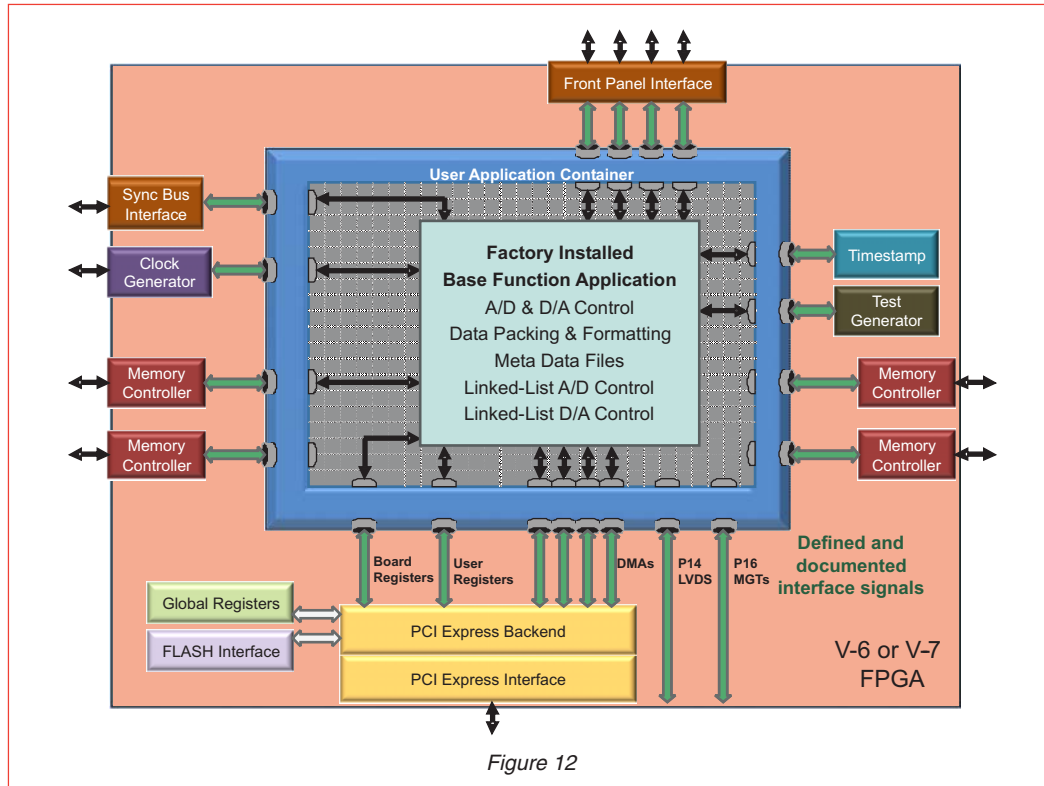

The GateFlow FPGA Design Kit allows the user to modify, replace and extend the standard factory-installed functions in the FPGA to incorporate special modes of operation, new control structures, and specialized signal-processing algorithms.

The Cobalt and Onyx architectures configure the FPGA with standard factory-supplied interfaces including memory controllers, DMA engines, A/D and D/A interfaces, timing and synchronization structures, triggering and gating logic, time stamping and header tagging, data formatting engines, and the PCIe interface. These resources are connected to the User Application Container using well-defined ports that present easy-to-use data and control signals, effectively abstracting the lower level details of the hardware.

Shown here is the FPGA block diagram of a typical Cobalt or Onyx module. The User Application Container holds a collection of different factory-installed IP modules connected to the various interfaces through the standard ports surrounding the container. The specific IP modules for each product are described in further detail in the datasheet of that product.

The GateFlow Design Kit provides a complete Xilinx ISE Foundation Tool project folder containing all the files necessary for the FPGA developer to recompile the entire project with or without any required changes. VHDL source code for each IP module provides excellent examples of how the IP modules work, how they might be modified, and how they might be replaced with custom IP to implement a specific function.



FPGA Resources

GateFlow FPGA Design Kit for Other Pentek Products

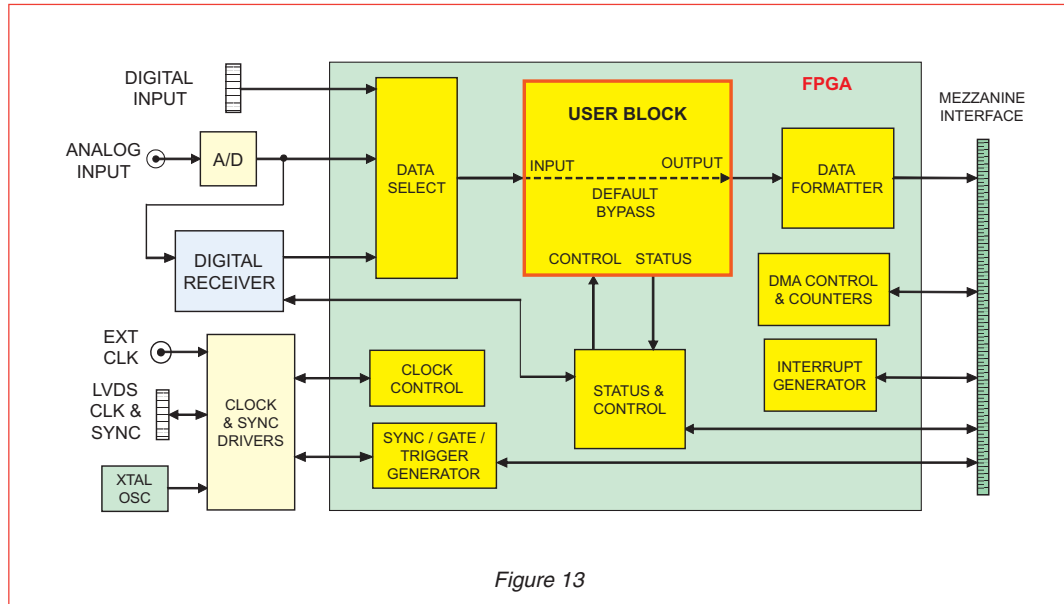

Figure 13

The GateFlow FPGA Design Kit is intended for the programming of predefined user blocks located in the data flow path specifically reserved for custom applications. These predefined blocks protect users from inadvertently altering base functionality.

Pentek recommends user programming be limited to the predefined user blocks to maintain base functionality. However, for more complex requirements, sufficient information is supplied in the kit for the user to modify, add to, or replace default board functions if necessary. Default configuration files are included with the Design Kit should it be necessary to restore standard factory configuration.

Shown above is the block diagram of a typical software radio module. The diagram includes the FPGA and external hardware devices connected to it.

The blocks inside the FPGA are VHDL code modules that handle the standard factory functions and interfaces. The User Block is a VHDL module that sits in the data path with pin definitions for input, output, status, control and clocks.

In the standard Design Kit product, the User Block is configured as a straight wire between the input and output ports. By creating a custom algorithm inside the block that conforms to the pin definition, the user will have a low-risk experience in recompiling and installing the custom code. Since Pentek provides source code for all the modules, changes outside the user block can also be made by the user.



FPGA Resources

GateFlow Installed IP Cores



- Pentek Installs IP Cores in Pentek Products
- Cores are tailored and optimized for:
 - Specific devices and I/O found on Pentek products
 - Efficient FPGA resource utilization
 - Execution and throughput speed
- Eliminates need for customer FPGA development
- Fully supported with ReadyFlow Board Support Libraries



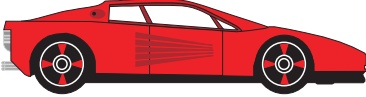

Figure 14

Pentek is an AllianceCore Member, a third party program sponsored by Xilinx for companies that specialize in specific areas of expertise in developing FPGA algorithms for niche application areas. These include image processing, communications, telecom, telemetry, signal intelligence, wireless communications, wireless networking, and many other disciplines.

Pentek offers popular high-performance signal processing algorithms installed in Pentek products. These algorithms are designed expressly for Xilinx FPGAs and Pentek hardware products. The cores take full advantage of the numerous hardware multipliers to achieve highly-parallel processing structures that can dramatically outperform programmable RISC and DSP processors.

Installed Cores are optimized for efficient FPGA resource utilization, execution and throughput speed. They are delivered to you preinstalled in your Pentek FPGA-based product of choice and are fully tested and supported with the Pentek ReadyFlow Board Support Packages. Purchasing these popular factory-installed cores saves you the time and costs of acquiring FPGA tools and developing custom FPGA code.

FPGA Resources

Digital Downconverter Fundamentals

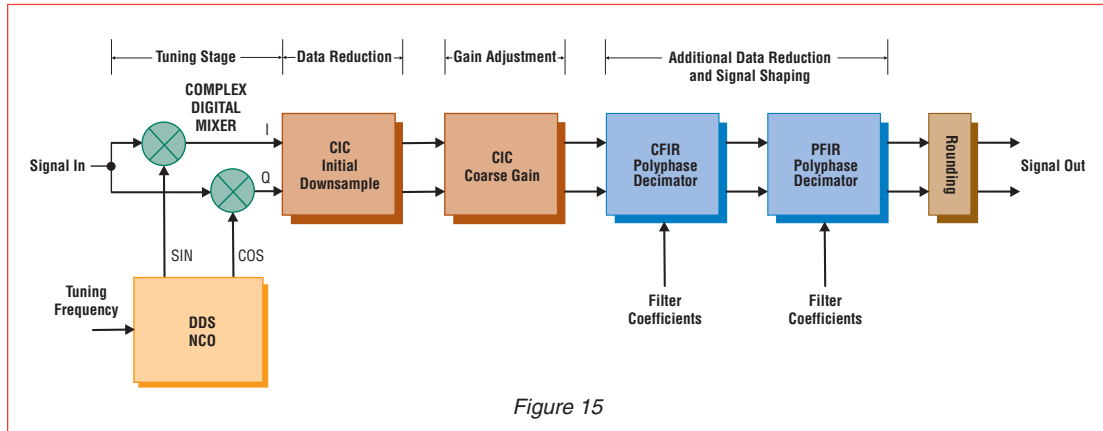

Figure 15

Over the past few years, the functions associated with DDCs have seen a shift from being delivered in ASICs (Application-Specific ICs) to operating as IP (Intellectual Property) in FPGAs.

For many applications, this implementation shift brings advantages that include: design flexibility, higher-precision processing, higher channel density, lower power, and lower cost per channel. With the advent of each new higher performance FPGA family during the past few years, these benefits continue to increase.

To understand how FPGAs play a key role in implementing DDCs that perform the function of a receiver, it's important to break the DDC down into its individual functional blocks. The block diagram shows a classic DDC. Regardless of whether it's implemented in an ASIC or an FPGA, this is the common architecture of the DDC function.

The first stage of the DDC uses a complex digital mixer to translate the frequency of interest down to baseband. It uses a pair of multipliers and a DDS (Direct Digital Synthesizer) as the NCO (Numerically Controlled Oscillator). This function enables the user to tune the receiver to the desired frequency of interest. The second stage of the DDC reduces the sampling frequency of the signal to match the desired output bandwidth. It uses a CIC (Cascaded Integrator Comb) filter to decimate the data.

A second CIC filter provides a coarse gain adjustment stage. The signal is then passed to a pair of additional polyphase filters. First a CFIR (Compensation Finite Impulse Response) filter then to a PFIR (Programmable Finite Impulse Response) filter. This filter pair provides additional decimation and final signal shaping prior to the rounding stage and final output.

When we get past all the acronyms, we realize that most of the individual function blocks of the DDC are implemented using multipliers. It thus becomes apparent how the DDC might map into current FPGA families. Most new FPGAs include a wealth of DSP function blocks which are primarily multipliers. The general-purpose logic resource and on-chip memory of FPGAs also match the requirements of the DDC for implementing the required FIR filters and filter coefficient tables.

As part of their IP library series, Xilinx provides a free DDC core. The core serves as a good general reference design, following the classic DDC architecture shown here. While this core can be used as a building block for general purpose DDCs, the real advantages of an IP-based implementation can be best seen in optimized custom cores that are designed to match the requirements of a specific application.

Pentek offers a series of high-performance IP-based DDCs and DUCs available preinstalled in their software radio boards. Each is optimized to match a specific range of application requirements. ➤

FPGA Resources

IP Enables Software Radio Products

These cores range from a 256-channel narrow bandwidth Core installed in the Model 7151 with quad 200 MHz A/D, to the extended interpolation Core installed in the Model 71671 with quad 1.25 GHz D/A.

These two and many other FPGA-based SDR products are available in industry-standard PMC/XMC modules as well as CompactPCI, PCI Express, AMC and OpenVPX formats.

When compared on a size/power/cost per channel basis, narrowband, high-channel-count DDC cores can be very efficiently implemented in FPGAs. Implementation of wideband DDCs consumes many more FPGA DSP and logic resources. As a result, the number of channels that can be fit into a single FPGA is limited. Even with less cost-effective wideband DDCs,

the custom IP approach can usually provide the only viable solution when a specific performance characteristic is required.

An additional benefit of IP-based solutions is the flexible nature of their implementation. These products are created by using the same hardware base with different installed IP cores. They all share the same software base allowing migration between different applications to be accomplished with minimum software porting.

Again, this wide range of applications can be satisfied by using a small set of hardware with different, optimized IP cores. This is one of the fundamental concepts of SDR (Software-Defined Radio), and it's difficult, if not impossible, to achieve with ASIC-based solutions.

Products

PMC, XMC, CompactPCI, PCI, PCI Express, OpenVPX, AMC, and VMEbus Software Radio

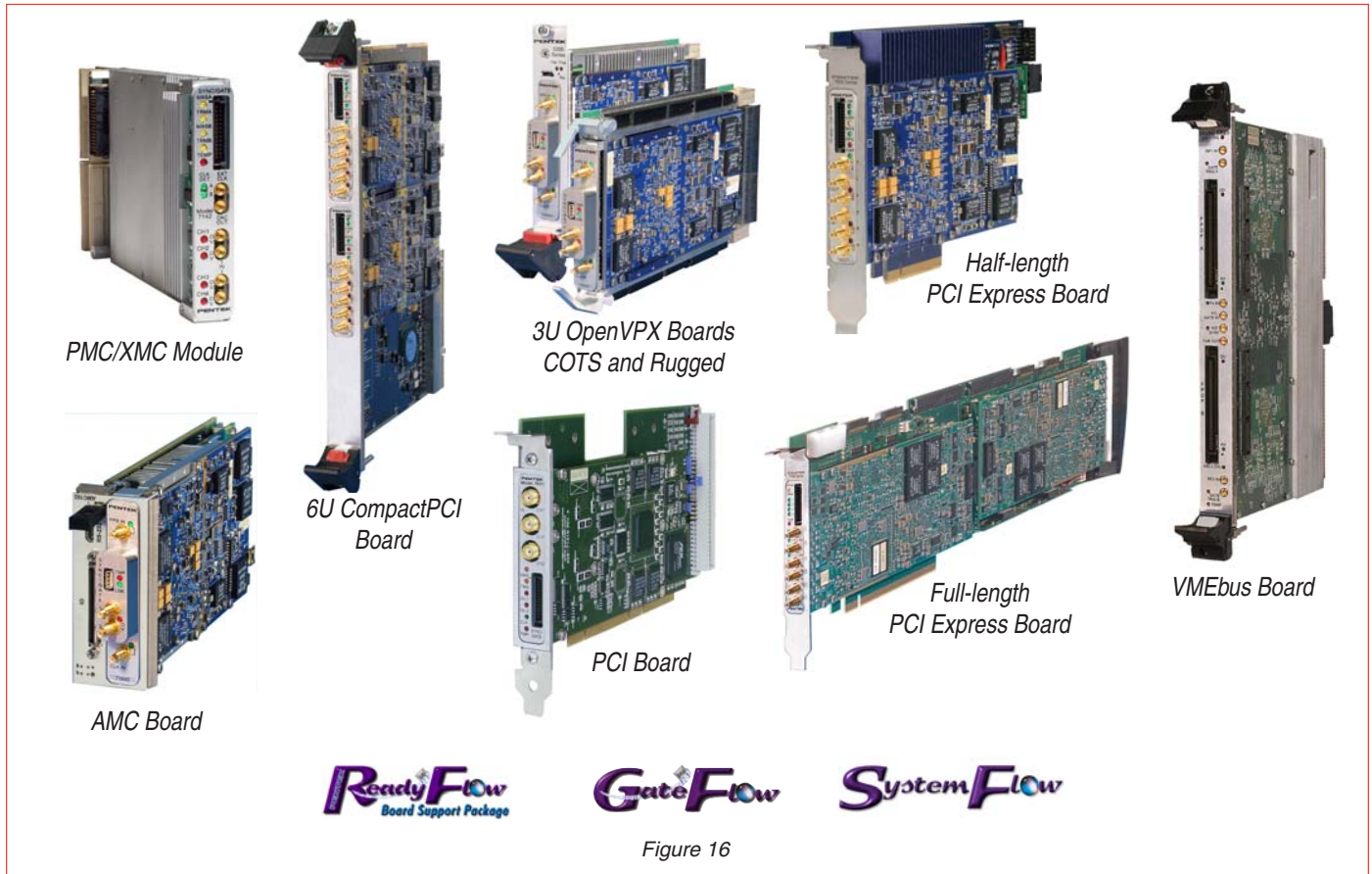

Figure 16

The Pentek family of board-level software radio products is the most comprehensive in the industry. Most of these products are available in several formats to satisfy a wide range of requirements.

In addition to their commercial versions, many software radio products are available in ruggedized and conduction-cooled versions.

Most of the software radio products include input A/D converters. Some of these products are software radio receivers in that they include only DDCs. Others are software radio transceivers and they include DDCs as well as DUCs with output D/A converters. These come with independent input and output clocks.

All Pentek software radio products include multiboard synchronization that facilitates the design of multichannel systems with synchronous clocking, gating and triggering.

Pentek's comprehensive software support includes the ReadyFlow[®] Board Support Package, the GateFlow[®] FPGA Design Kit and high-performance factory-installed IP cores that expand the features and range of many Pentek software radio products. In addition, Pentek high-speed recording systems are supported with SystemFlow[®] recording software that features a graphical user interface.

In addition to product overviews presented in the pages that follow, a complete listing of these products with active links to their datasheets on Pentek's website is included at the end of this handbook.

Products

Multichannel Transceivers with Virtex-4 FPGAs

**Model 7142 PMC/XMC • Model 7242 6U cPCI • Model 7342 3U cPCI • Model 7642 PCI
Model 7742 Full-length PCIe • Model 7842 Half-length PCIe • Model 5342 3U VPX**

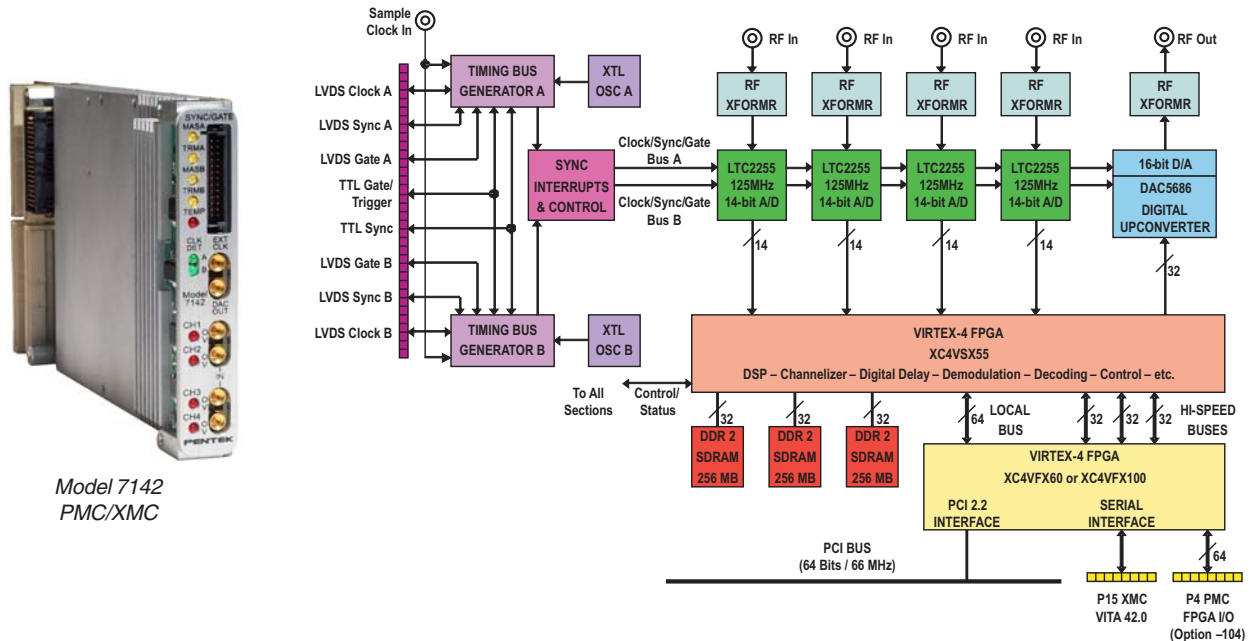

Figure 17

The Model 7142 is a Multichannel PMC/XMC module. It includes four 125 MHz 14-bit A/D converters and one upconverter with a 500 MHz 16-bit D/A converter to support wideband receive and transmit communication channels.

Two Xilinx Virtex-4 FPGAs are included: an XC4VSX55 or LX100 and an XC4VFX60 or FX100. The first FPGA is used for control and signal processing functions, while the second one is used for implementing board interface functions including the XMC interface.

It also features 768 MB of SDRAM for implementing up to 2.0 sec of transient capture or digital delay memory for signal intelligence tracking applications at 125 MHz.

A 16 MB flash memory supports the boot code for the two on-board IBM 405 PowerPC microcontroller cores within the FPGA.

A 9-channel DMA controller and 64 bit / 66 MHz PCI interface assures efficient transfers to and from the module.

A high-performance 160 MHz IP core wideband digital downconverter may be factory-installed in the first FPGA.

Two 4X switched serial ports, implemented with the Xilinx Rocket I/O interfaces, connect the second FPGA to the XMC connector with two 2.5 GB/sec data links to the carrier board.

A dual bus system timing generator allows separate clocks, gates and synchronization signals for the A/D and D/A converters. It also supports large, multichannel applications where the relative phases must be preserved.

Versions of the 7142 are also available as a PCIe full-length board (Models 7742 and 7742D dual density), PCIe half-length board (Model 7842), 3U VPX (Model 5342), PCI board (Model 7642), 6U cPCI (Models 7242 and 7242D dual density), and 3U cPCI (Model 7342).

Products

Transceivers with Four Multiband DDCs and Interpolation Filter Installed Cores

**Model 7142-428 PMC/XMC • Model 7242-428 6U cPCI • Model 7342-428 3U cPCI
Model 7642-428 PCI • Model 7742-428 Full-length PCIe
Model 7742-428 Half-length PCIe • Model 5342-428 3U VPX**

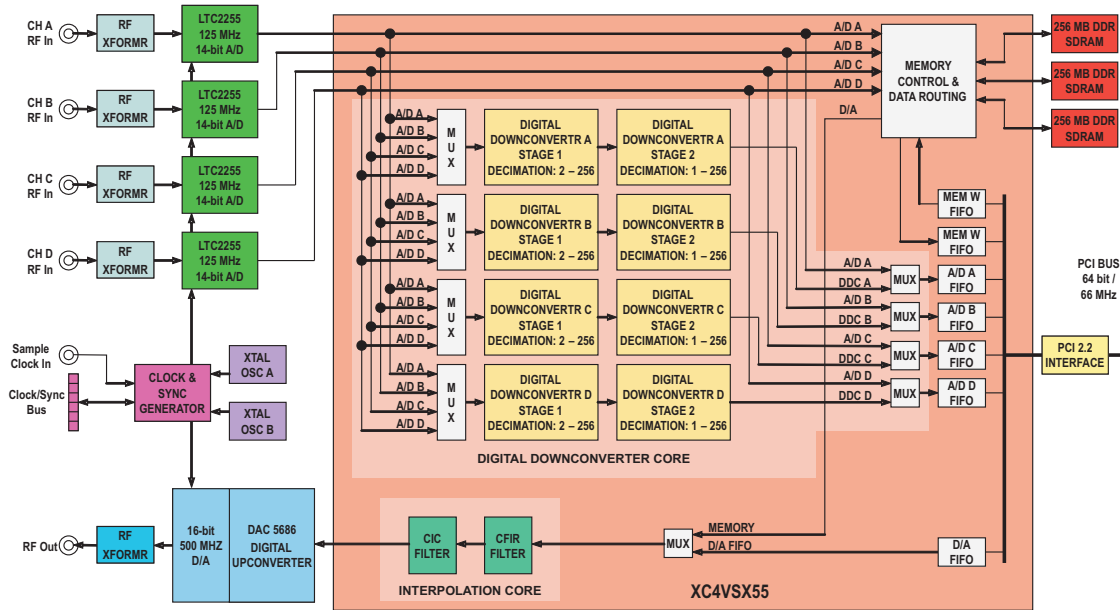

Figure 18

The Pentek IP Core 428 includes four high-performance multiband DDCs and an interpolation filter. Factory-installed in the Model 7142 FPGA, they add DDCs to the Model 7142 and extend the range of its DAC5686 DUC.

The Core 428 downconverter translates any frequency band within the input bandwidth range down to zero frequency. The DDCs consist of two cascaded decimating FIR filters. The decimation of each DDC can be set independently. After each filter stage is a post filter gain stage. This gain may be used to amplify small signals after out-of-band signals have been filtered out.

The NCO provides over 108 dB spurious-free dynamic range (SFDR). The FIR filter is capable of storing and utilizing two independent sets of 18-bit coefficients. These coefficients are user-programmable by using RAM structures within the FPGA. NCO tuning frequency, decimation and filter coefficients can be changed dynamically.

Four identical Core 428 DDCs are factory installed in the 7142-428 FPGA. An input multiplexer allows any DDC to independently select any of the four A/D sources. The overall decimation range from 2 to 65,536, programmable in steps of 1, provides output bandwidths from 50 MHz down to 1.52 kHz for an A/D sampling rate of 125 MHz and assuming an 80% filter.

The Core 428 interpolation filter increases the sampling rate of real or complex baseband signals by a factor of 16 to 2048, programmable in steps of 4, and relieves the host processor from performing upsampling tasks. The interpolation filter can be used in series with the DUC's built-in interpolation, for a maximum interpolation of 32,768.

Versions of the 7142-428 are also available as a PCIe full-length board (Models 7742-428 and 7742D-428 dual density), PCIe half-length board (Model 7842-428), PCI board (Model 7642-428), 6U cPCI (Models 7242-428 and 7242D-428 dual density), 3U cPCI (Model 7342-428), and 3U VPX (Model 5342-428).

Products

Quad 200 MHz 16-bit A/D with Virtex-5 FPGAs

**Model 7150 PMC/XMC • Model 7250 6U cPCI • Model 7350 3U cPCI • Model 7650 PCI
Model 7750 Full-length PCIe • Model 7850 Half-length PCIe • Model 5350 3U VPX**

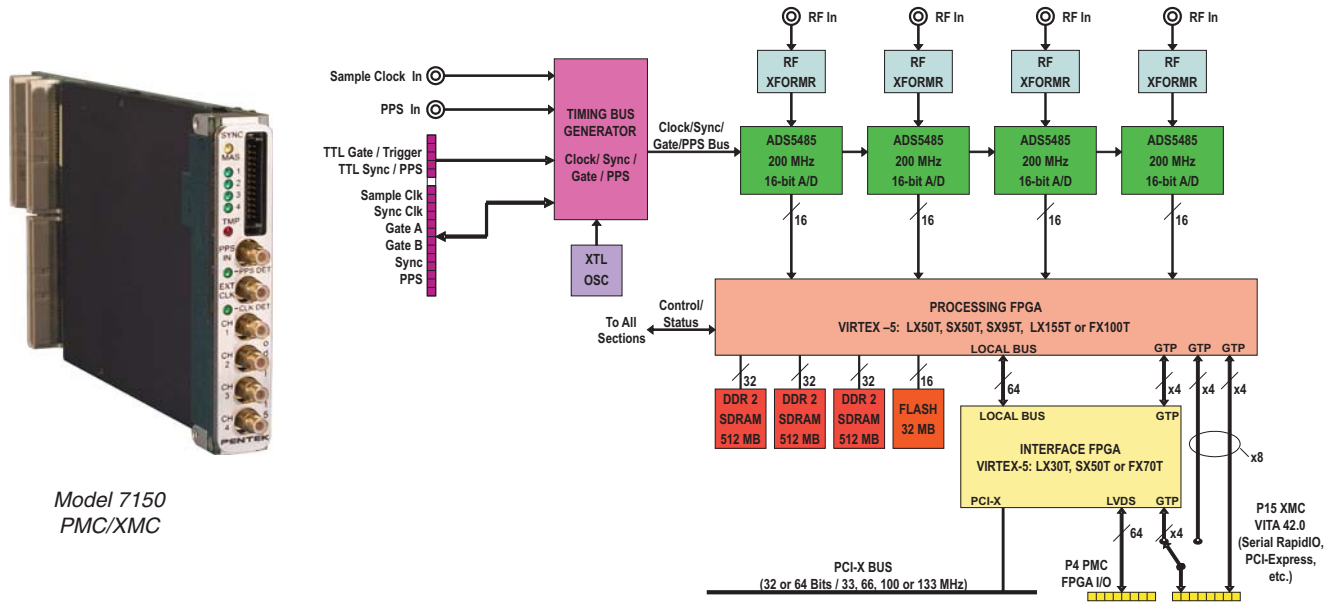

Model 7150
PMC/XMC

Figure 19

Model 7150 is a quad, high-speed data converter suitable for connection as the HF or IF input of a communications system. It features four 200 MHz, 16-bit A/Ds supported by an array of data processing and transport resources ideally matched to the requirements of high-performance systems. Model 7150 uses the popular PMC format and supports the emerging VITA 42 XMC standard for switched fabric interfaces.

The Model 7150 architecture includes two Virtex-5 FPGAs. The first FPGA is used primarily for signal processing while the second one is dedicated to board interfaces. All of the board's data and control paths are accessible by the FPGAs, enabling factory installed functions including data multiplexing, channel selection, data packing, gating, triggering and SDRAM memory control.

Three independent 512 MB banks of DDR2 SDRAM are available to the signal processing FPGA. Built-in memory functions include an A/D data transient

capture mode with pre- and post-triggering. All memory banks can be easily accessed through the PCI-X interface.

A 9-channel DMA controller and 64 bit / 100 MHz PCI-X interface assures efficient transfers to and from the module.

Two 4X switched serial ports, implemented with the Xilinx Rocket I/O interfaces, connect the FPGA to the XMC connector with two 2.5 GB/sec data links to the carrier board.

A dual bus system timing generator allows separate clocks, gates and synchronization signals for the A/D converters. It also supports large, multichannel applications where the relative phases must be preserved.

Versions of the 7150 are also available as a PCIe full-length board (Models 7750 and 7750D dual density), PCIe half-length board (Model 7850), PCI board (Model 7650), 6U cPCI (Models 7250 and 7250D dual density), 3U cPCI (Model 7350), and 3U VPX (Model 5350).

Products

256-Channel DDC Installed Core with Quad 200 MHz, 16-bit A/D

**Model 7151 PMC • Model 7251 6U cPCI • Model 7351 3U cPCI • Model 7651 PCI
Model 7751 Full-length PCIe • Model 7851 Half-length PCIe • Model 5351 3U VPX**

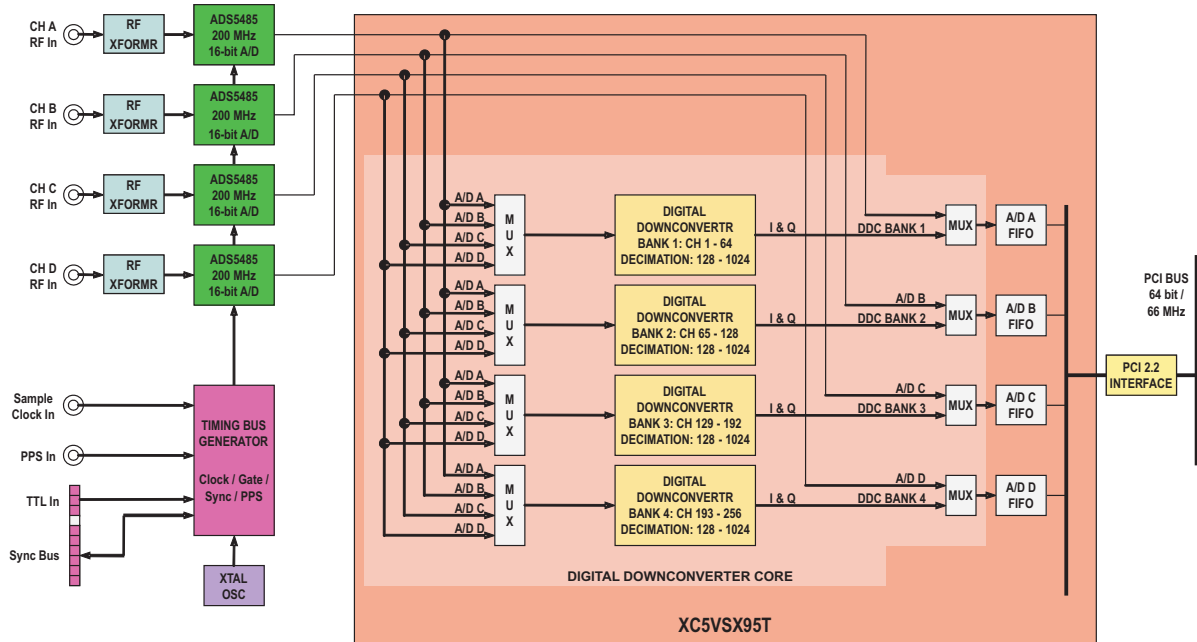

Figure 20

The Model 7151 PMC module is a 4-channel high-speed digitizer with a factory-installed 256-channel DDC core. The front end of the module accepts four RF inputs and transformer-couples them into four 16-bit A/D converters running at 200 MHz. The digitized output signals pass to a Virtex-5 FPGA for routing, formatting and DDC signal processing.

The Model 7151 employs an advanced FPGA-based digital downconverter engine consisting of four identical 64-channel DDC banks. Four independently controllable input multiplexers select one of the four A/Ds as the input source for each DDC bank. Each of the 256 DDCs has an independent 32-bit tuning frequency setting.

All of the 64 channels within a bank share a common decimation setting that can range from 128 to 1024, programmable in steps of 64. For example, with a sampling rate of 200 MHz, the available output bandwidths range from 156.25 kHz to 1.25 MHz. Each 64-channel bank can have its own unique decimation setting

supporting as many as four different output bandwidths for the board.

The decimating filter for each DDC bank accepts a unique set of user-supplied 18-bit coefficients. The 80% default filters deliver an output bandwidth of $0.8 \cdot f_s / N$, where N is the decimation setting. The rejection of adjacent-band components within the 80% output bandwidth is better than 100 dB.

Each DDC delivers a complex output stream consisting of 24-bit I + 24-bit Q samples. Any number of channels can be enabled within each bank, selectable from 0 to 64. Each bank includes an output sample interleaver that delivers a channel-multiplexed stream for all enabled channels within the bank.

Versions of the 7151 are also available as a PCIe full-length board (Models 7751 and 7751D dual density), PCIe half-length board (Model 7851), PCI board (Model 7651), 6U cPCI (Models 7251 and 7251D dual density), 3U cPCI (Model 7351), and 3U VPX (Model 5351).

Products

32-Channel DDC Installed Core with Quad 200 MHz, 16-bit A/D

**Model 7152 PMC • Model 7252 6U cPCI • Model 7352 3U cPCI • Model 7652 PCI
Model 7752 Full-length PCIe • Model 7852 Half-length PCIe • Model 5352 3U VPX**

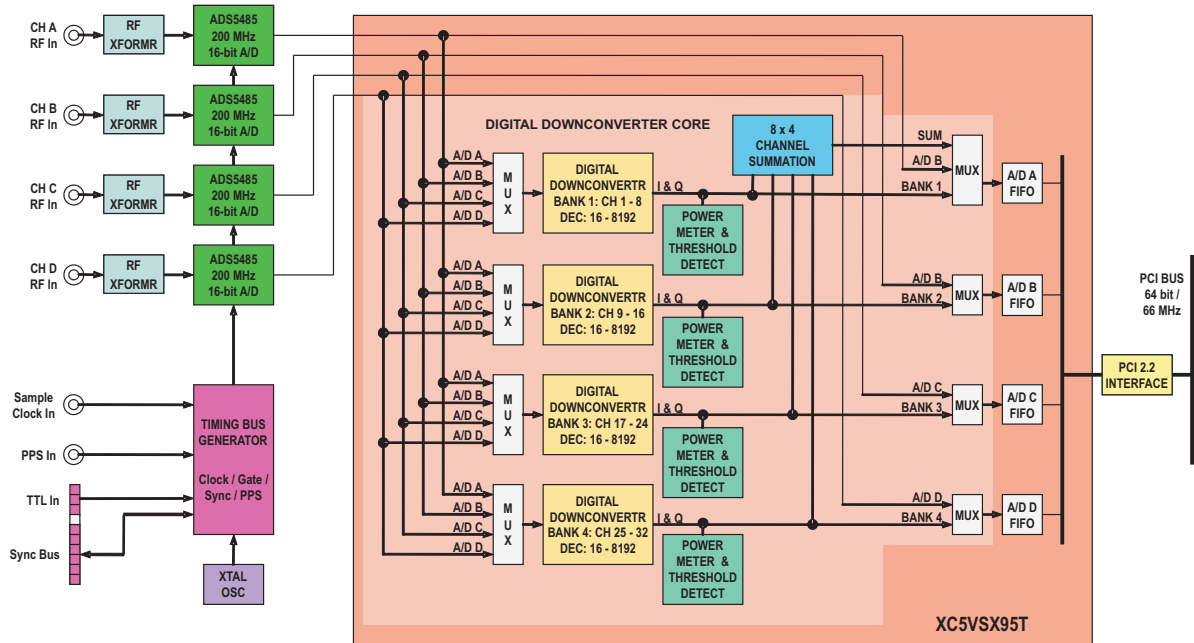

Figure 21

The Model 7152 PMC module is a 4-channel high-speed digitizer with a factory-installed 32-channel DDC core. The front end of the module accepts four RF inputs and transformer-couples them into four 16-bit A/D converters running at 200 MHz. The digitized output signals pass to a Virtex-5 FPGA for routing, formatting and DDC signal processing.

The Model 7152 employs an advanced FPGA-based digital downconverter engine consisting of four identical 8-channel DDC banks. Four independently controllable input multiplexers select one of the four A/Ds as the input source for each DDC bank. Each of the 32 DDCs has an independent 32-bit tuning frequency setting.

All of the 8 channels within a bank share a common decimation setting that can range from 16 to 8192, programmable in steps of 8. For example, with a sampling rate of 200 MHz, the available output bandwidths range from 19.53 kHz to 10.0 MHz. Each 8-channel bank can

have its own unique decimation setting supporting as many as four different output bandwidths for the board.

The decimating filter for each DDC bank accepts a unique set of user-supplied 18-bit coefficients. The 80% default filters deliver an output bandwidth of $0.8 \cdot f_s / N$, where N is the decimation setting. The rejection of adjacent-band components within the 80% output band-width is better than 100 dB.

Each DDC delivers a complex output stream consisting of 24-bit I + 24-bit Q samples. Any number of channels can be enabled within each bank, selectable from 0 to 8. Each bank includes an output sample interleaver that delivers a channel-multiplexed stream for all enabled channels within the bank. Gain and phase control, power meters and threshold detectors are included.

Versions of the 7152 are also available as a PCIe full-length board (Models 7752 and 7752D dual density), PCIe half-length board (Model 7852), PCI board (Model 7652), 6U cPCI (Models 7252 and 7252D dual density), 3U cPCI (Model 7352), and 3U VPX (Model 5352).

Products

4-Channel DDC and Beamformer Installed Core with four 200 MHz, 16-bit A/Ds

**Model 7153 PMC/XMC • Model 7253 6U cPCI • Model 7353 3U cPCI • Model 7653 PCI
Model 7753 Full-length PCIe • Model 7853 Half-length PCIe • Model 5353 3U VPX**

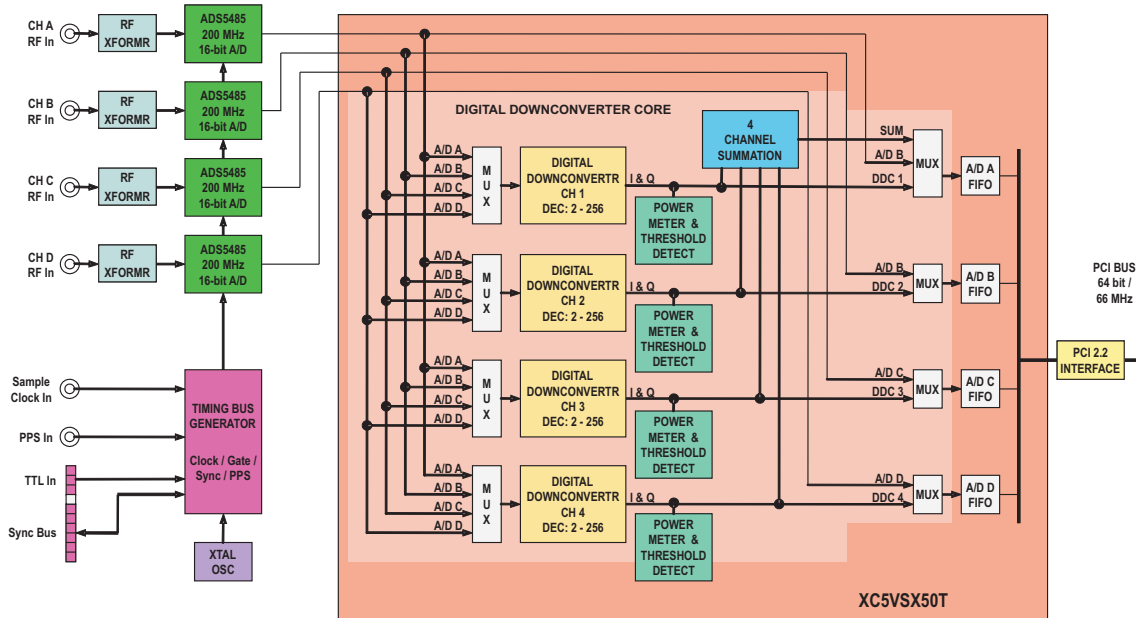

Figure 22

Model 7153 is a 4-channel, high-speed software radio module designed for processing baseband RF or IF signals. It features four 200 MHz 16-bit A/Ds supported by a high-performance 4-channel DDC (digital downconverter) installed core and a complete set of beamforming functions. With built-in multiboard synchronization and an Aurora gigabit serial interface, it provides everything needed for implementing multichannel beamforming systems.

The Model 7153 employs an advanced FPGA-based DDC engine consisting of four identical multiband banks. Four independently controllable input multiplexers select one of the four A/Ds as the input source for each DDC bank. Each of the 4 DDCs has an independent 32-bit tuning frequency setting.

All four DDCs have a decimation setting that can range from 2 to 256, programmable independently in steps of 1. The decimating filter for each DDC bank accepts a unique set of user-supplied 18-bit coefficients. The 80% default filters deliver an output bandwidth of

$0.8 * f_s / N$, where N is the decimation setting. The rejection of adjacent-band components within the 80% output band-width is better than 100 dB.

In addition to the DDCs, the 7153 features a complete beamforming subsystem. Each channel contains programmable I & Q phase and gain adjustments followed by a power meter that continuously measures the individual average power output. The time constant of the averaging interval for each meter is programmable up to 8 ksamples. The power meters present average power measurements for each channel in easy-to-read registers. Each channel also includes a threshold detector that sends an interrupt to the processor if the average power level of any DDC falls below or exceeds a programmable threshold.

Versions of the 7153 are also available as a PCIe full-length board (Models 7753 and 7753D dual density), PCIe half-length board (Model 7853), PCI board (Model 7653), 6U cPCI (Models 7253 and 7253D dual density), 3U cPCI (Model 7353), and 3U VPX (Model 5353).

Products

Dual SDR Transceivers with 400 MHz A/D, 800 MHz D/A, and Virtex-5 FPGAs

**Model 7156 PMC/XMC • Model 7256 6U cPCI • Model 7356 3U cPCI • Model 7656 PCI
Model 7756 Full-length PCIe • Model 7856 Half-length PCIe • Model 5356 3U VPX**

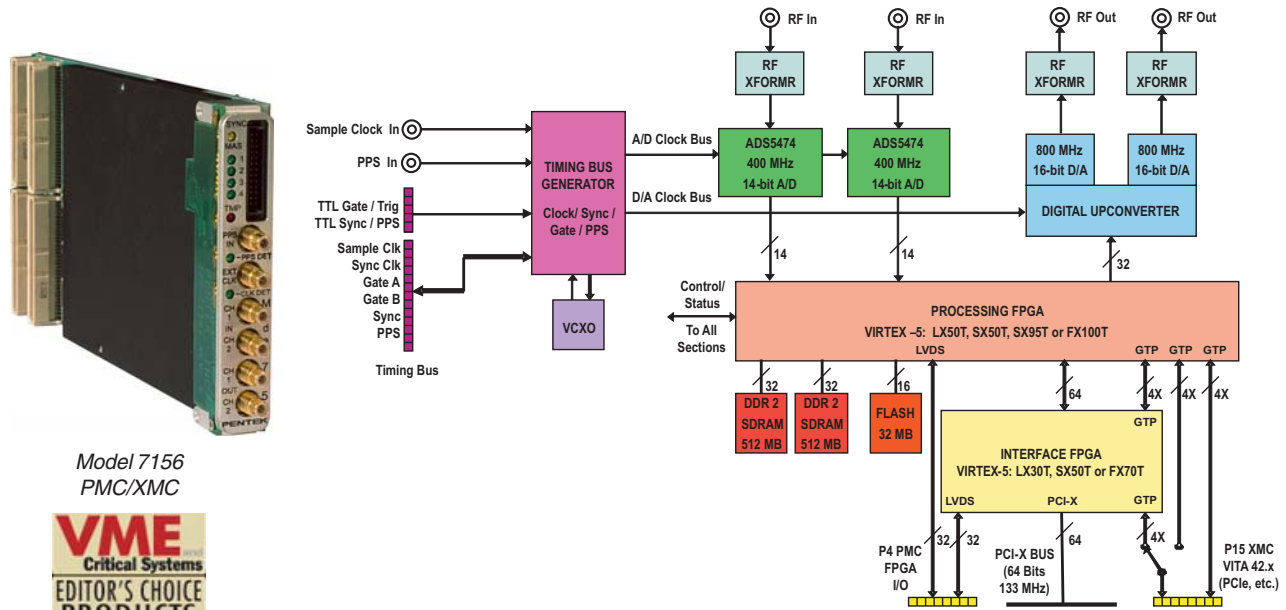

Figure 23

Model 7156 is a dual high-speed data converter suitable for connection as the HF or IF input of a communications system. It features two 400 MHz 14-bit A/Ds, a DUC with two 800 MHz 16-bit D/As, and two Virtex-5 FPGAs. Model 7156 uses the popular PMC format and supports the VITA 42 XMC standard for switched fabric interfaces.

The Model 7156 architecture includes two Virtex-5 FPGAs. The first FPGA is used primarily for signal processing while the second one is dedicated to board interfaces. All of the board's data and control paths are accessible by the FPGAs, enabling factory installed functions such as data multiplexing, channel selection, data packing, gating, triggering and SDRAM memory control.

Two independent 512 MB banks of DDR2 SDRAM are available to the signal processing FPGA. Built-in memory functions include an A/D data transient capture mode with pre- and post-triggering. All memory banks can be easily accessed through the PCI-X interface.

A high-performance IP core wideband DDC may be factory-installed in the processing FPGA.

A 5-channel DMA controller and 64 bit/100 MHz PCI-X interface assures efficient transfers to and from the module.

Two 4X switched serial ports implemented with the Xilinx Rocket I/O interfaces, connect the FPGA to the XMC connector with two 2.5 GB/sec data links to the carrier board.

A dual bus system timing generator allows for sample clock synchronization to an external system reference. It also supports large, multichannel applications where the relative phases must be preserved.

Versions of the 7156 are also available as a PCIe full-length board (Models 7756 and 7756D dual density), PCIe half-length board (Model 7856), PCI board (Model 7656), 6U cPCI (Models 7256 and 7256D dual density), 3U cPCI (Model 7356), and 3U VPX (Model 5356). All these products have similar features.

Products

Dual SDR Transceivers with 500 MHz A/D, 800 MHz D/A, and Virtex-5 FPGAs

**Model 7158 PMC/XMC • Model 7258 6U cPCI • Model 7358 3U cPCI • Model 7658 PCI
Model 7758 Full-length PCIe • Model 7858 Half-length PCIe • Model 5358 3U VPX**

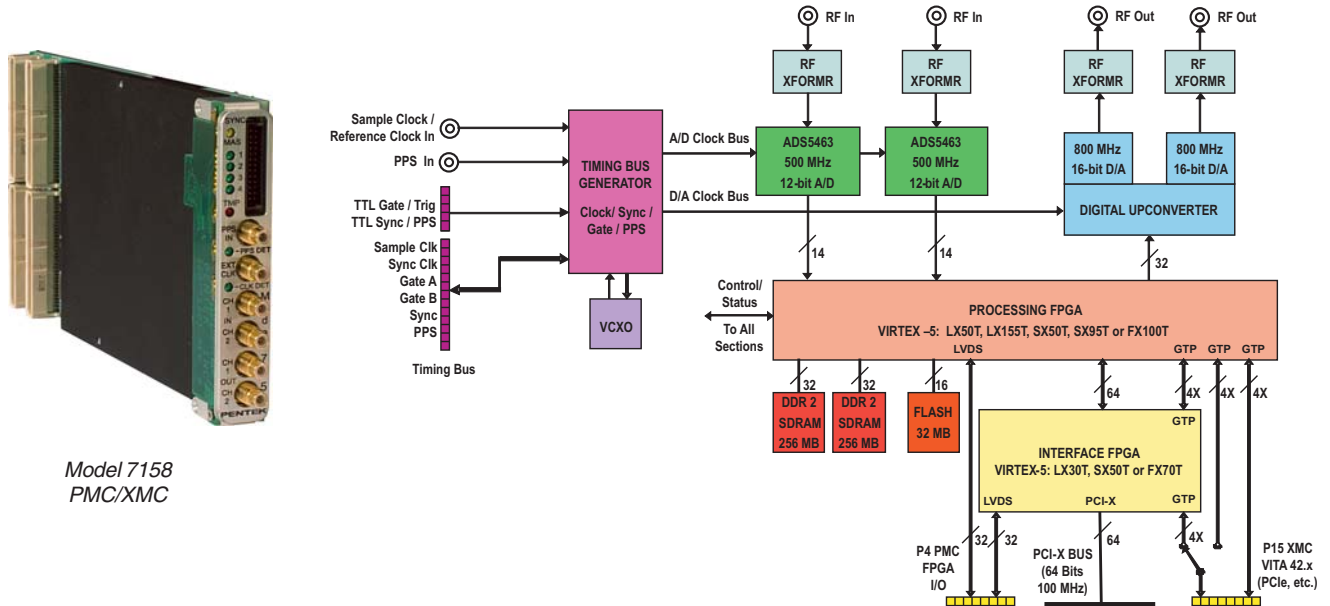

Model 7158
PMC/XMC

Figure 24

Model 7158 is a dual high-speed data converter suitable for connection as the HF or IF input of a communications system. It features two 500 MHz 12-bit A/Ds, a digital upconverter with two 800 MHz 16-bit D/As, and two Virtex-5 FPGAs. Model 7158 uses the popular PMC format and supports the VITA 42 XMC standard for switched fabric interfaces.

The Model 7158 architecture includes two Virtex-5 FPGAs. The first FPGA is used primarily for signal processing while the second one is dedicated to board interfaces. All of the board's data and control paths are accessible by the FPGAs, enabling factory installed functions such as data multiplexing, channel selection, data packing, gating, triggering and SDRAM memory control.

Two independent 256 MB banks of DDR2 SDRAM are available to the signal processing FPGA. Built-in memory functions include an A/D data transient capture mode with pre- and post-triggering. All memory banks can be easily accessed through the PCI-X interface.

A 5-channel DMA controller and 64 bit / 100 MHz PCI-X interface assures efficient transfers to and from the module.

Two 4X switched serial ports implemented with the Xilinx Rocket I/O interfaces, connect the FPGA to the XMC connector with two 2.5 GB/sec data links to the carrier board.

A dual bus system timing generator allows for sample clock synchronization to an external system reference. It also supports large, multichannel applications where the relative phases must be preserved.

Versions of the 7158 are also available as a PCIe full-length board (Models 7758 and 7758D dual density), PCIe half-length board (Model 7858), PCI board (Model 7658), 6U cPCI (Models 7258 and 7258D dual density), 3U cPCI (Model 7358), and 3U VPX (Model 5358). All these products have similar features.

Products

3-Channel 200 MHz A/D, DUC, 2-Channel 800 MHz D/A, Virtex-6 FPGA

**Model 71620 XMC • Model 78620 PCIe • Model 52620 3U VPX • Model 53620 3U VPX
Model 56620 AMC • Model 72620 6U cPCI • Model 73620 3U cPCI • Model 74620 6U cPCI**

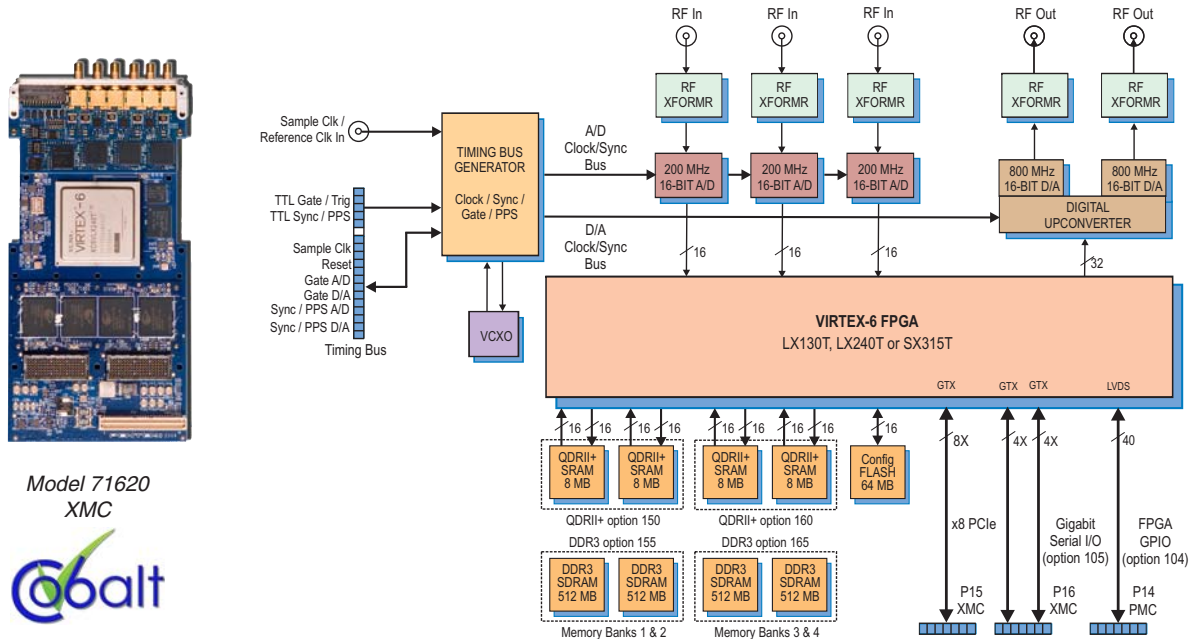

Model 71620
XMC



Figure 25

Model 71620 is a member of the Cobalt® family of high performance XMC modules based on the Xilinx Virtex-6 FPGA. A multichannel, high-speed data converter, it is suitable for connection to HF or IF ports of a communications or radar system. Its built-in data capture and playback features offer an ideal turnkey solution. It includes three 200 MHz, 16-bit A/Ds, a DUC with two 800 MHz, 16-bit D/As and four banks of memory. In addition to supporting PCI Express Gen. 2 as a native interface, the Model 71620 includes general purpose and gigabit serial connectors for application-specific I/O .

The Pentek Cobalt architecture features a Virtex-6 FPGA. All of the board's data and control paths are accessible by the FPGA, enabling factory-installed functions including data multiplexing, channel selection, data packing, gating, triggering and memory control. The Cobalt architecture organizes the FPGA as a container for data processing applications where each function exists as an intellectual property (IP) module.

Each member of the Cobalt family is delivered with factory-installed applications ideally matched to the board's analog interfaces. The 71620 factory-installed functions include an A/D acquisition and a D/A waveform playback IP module. In addition, IP modules for either DDR3 or QDRII+ memories, a controller for all data clocking and synchronization functions, a test signal generator and a PCIe interface complete the factory-installed functions.

Multiple 71620's can be driven from the LVPECL bus master, supporting synchronous sampling and sync functions across all connected modules. The architecture supports up to four memory banks which can be configured with all QDRII+ SRAM, DDR3 SDRAM, or as combination of two banks of each type of memory.

Versions of the 71620 are also available as a PCIe half-length board (Model 78620), 3U VPX (Models 52620 and 53620), AMC (Model 56620), 6U cPCI (Models 72620 and 74620 with dual density), and 3U cPCI (Model 73620).

Products

3-Channel 200 MHz A/D, DUC, 2-Channel 800 MHz D/A, Virtex-7 FPGA

**Model 71720 XMC • Model 78720 PCIe • Model 52720 3U VPX • Model 53720 3U VPX
Model 56720 AMC • Model 72720 6U cPCI • Model 73720 3U cPCI • Model 74720 6U cPCI**

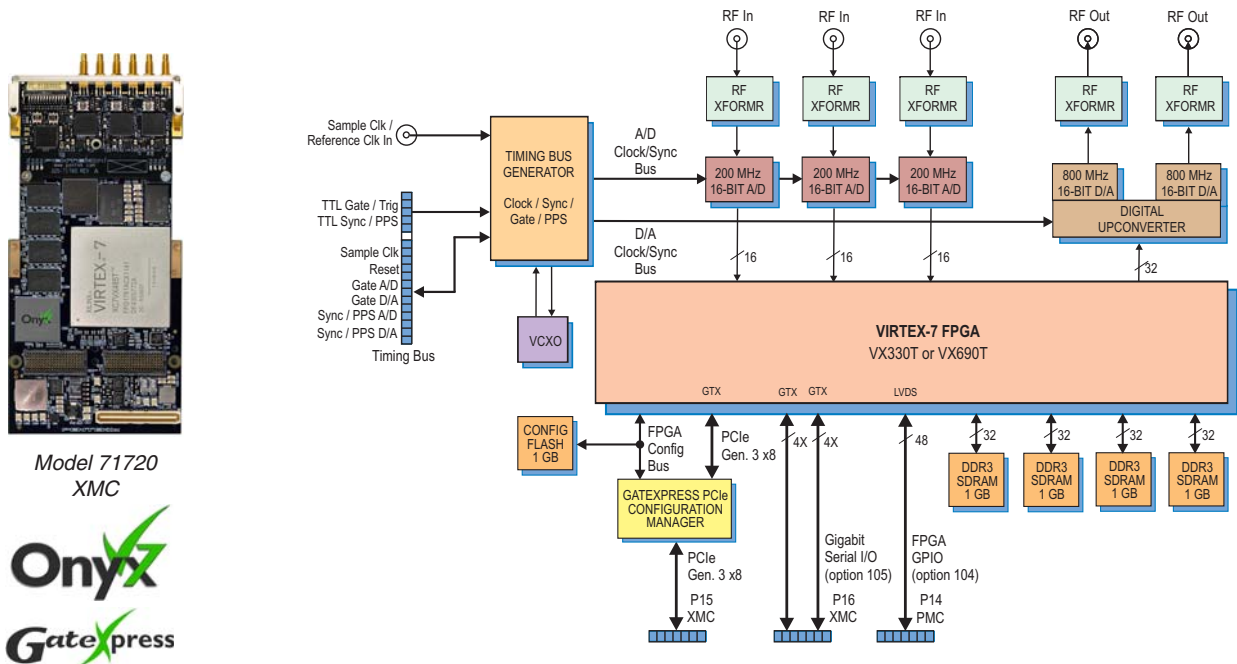

Figure 26

Model 71720 is a member of the Onyx[®] family of high-performance XMC modules based on the Xilinx Virtex-7 FPGA. A multichannel, high-speed data converter, it is suitable for connection to HF or IF ports of a communications or radar system. Its built-in data capture and playback features offer an ideal turnkey solution. It includes three 200 MHz, 16-bit A/Ds, a DUC with two 800 MHz, 16-bit D/As and four banks of memory. In addition to supporting PCI Express Gen. 3 as a native interface, the Model 71720 includes general-purpose and gigabit-serial connectors for application-specific I/O.

The Pentek Onyx architecture features a Virtex-7 FPGA. All of the board's data and control paths are accessible by the FPGA, enabling factory-installed functions including data multiplexing, channel selection, data packing, gating, triggering and memory control. The Cobalt architecture organizes the FPGA as a container for data processing applications where each function exists as an intellectual property (IP) module.

Each member of the Onyx family is delivered with factory-installed applications ideally matched to the board's analog interfaces. The 71720 factory-installed functions include three A/D acquisition and a D/A waveform playback IP modules for simplifying data capture and data transfer. IP modules for DDR3 SDRAM memories, a controller for all data clocking and synchronization functions, a test signal generator, and a PCIe interface complete the factory-installed functions.

Multiple 71720's can be driven from the LVPECL bus master, supporting synchronous sampling and sync functions across all connected modules.

Versions of the 71720 are also available as a PCIe half-length board (Model 78720), 3U VPX (Models 52720 and 53720), AMC (Model 56720), 6U cPCI (Models 72720 and 74720 with dual density), and 3U cPCI (Model 73720).

GateXpress[®] is a sophisticated configuration manager for loading and reloading the Virtex-7 FPGA. More information is available in the next page.

Products

GateXpress for FPGA-PCIe Configuration Management

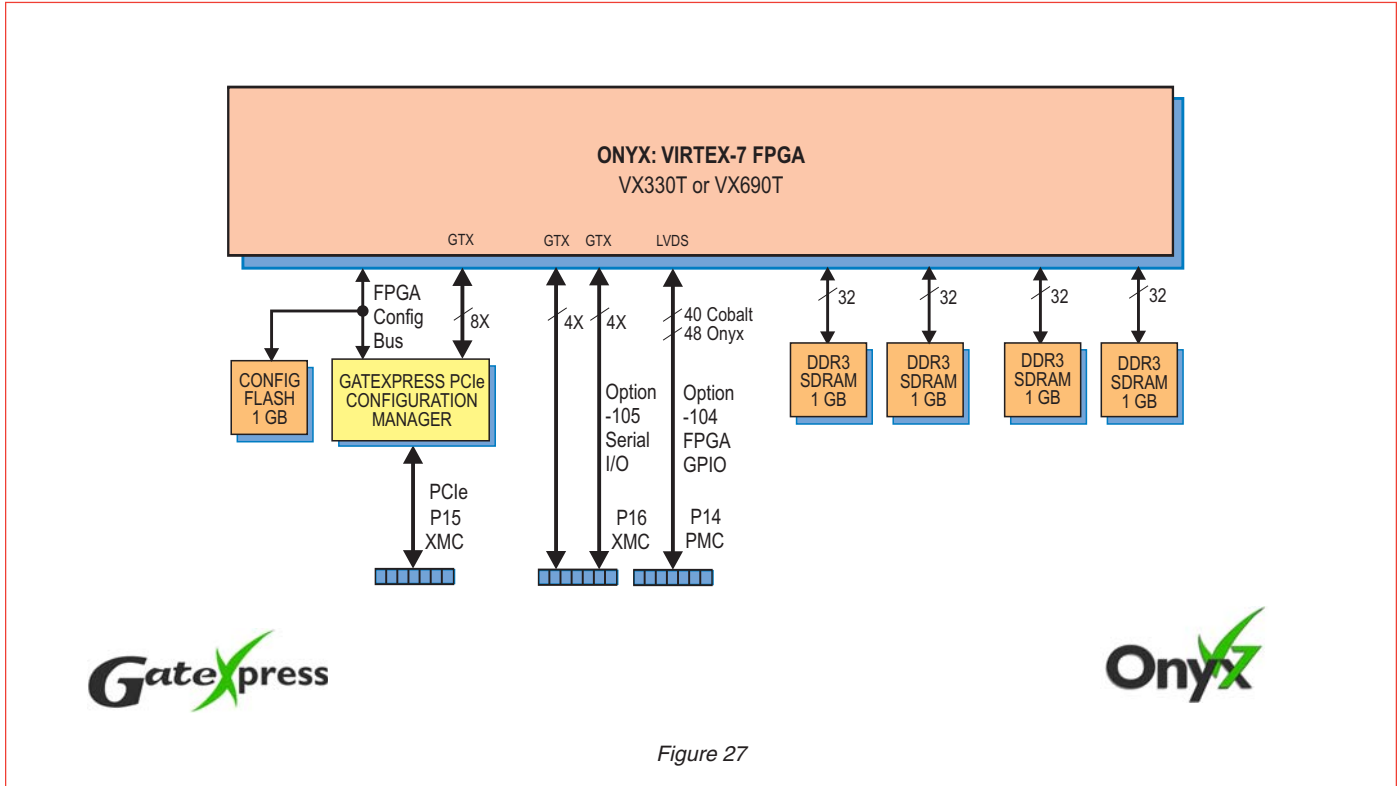

The Onyx architecture includes GateXpress®, a sophisticated FPGA-PCIe configuration manager for loading and reloading the FPGA. At power up, GateXpress immediately presents a PCIe target for the host computer to discover, effectively giving the FPGA time to load from FLASH. This is especially important for larger FPGAs where the loading times can exceed the PCIe discovery window, typically 100 msec on most PCs.

The board's configuration FLASH can hold four FPGA images. Images can be factory-installed IP or custom IP created by the user, and programmed into the FLASH via JTAG using Xilinx iMPACT or through the board's PCIe interface. At power up the user can choose which image will load based on a hardware switch setting.

Once booted, GateXpress allows the user three options for dynamically reconfiguring the FPGA with a new IP image. The first is the option to load an alternate image from FLASH through software control. The user selects the desired image and issues a reload command.

The second option is for applications where the FPGA image must be loaded directly through the PCIe interface. This is important in security situations where there can be no latent user image left in nonvolatile memory when power is removed. In applications where the FPGA IP may need to change many times during the course of a mission, images can be stored on the host computer and loaded through PCIe as needed.

The third option, typically used during development, allows the user to directly load the FPGA through JTAG using Xilinx iMPACT.

In all three FPGA loading scenarios, GateXpress handles the hardware negotiation simplifying and streamlining the loading task. In addition, GateXpress preserves the PCIe configuration space allowing dynamic FPGA reconfiguration without needing to reset the host computer to rediscover the board. After the reload, the host simply continues to see the board with the expected device ID.

Products

3-Channel 200 MHz A/D, DUC, 2-Channel 800 MHz D/A, Installed IP Cores, Virtex-6 FPGA

**Model 71621 XMC • Model 78621 PCIe • Model 52621 3U VPX • Model 53621 3U VPX
Model 56621 AMC • Model 72621 6U cPCI • Model 73621 3U cPCI • Model 74621 6U cPCI**

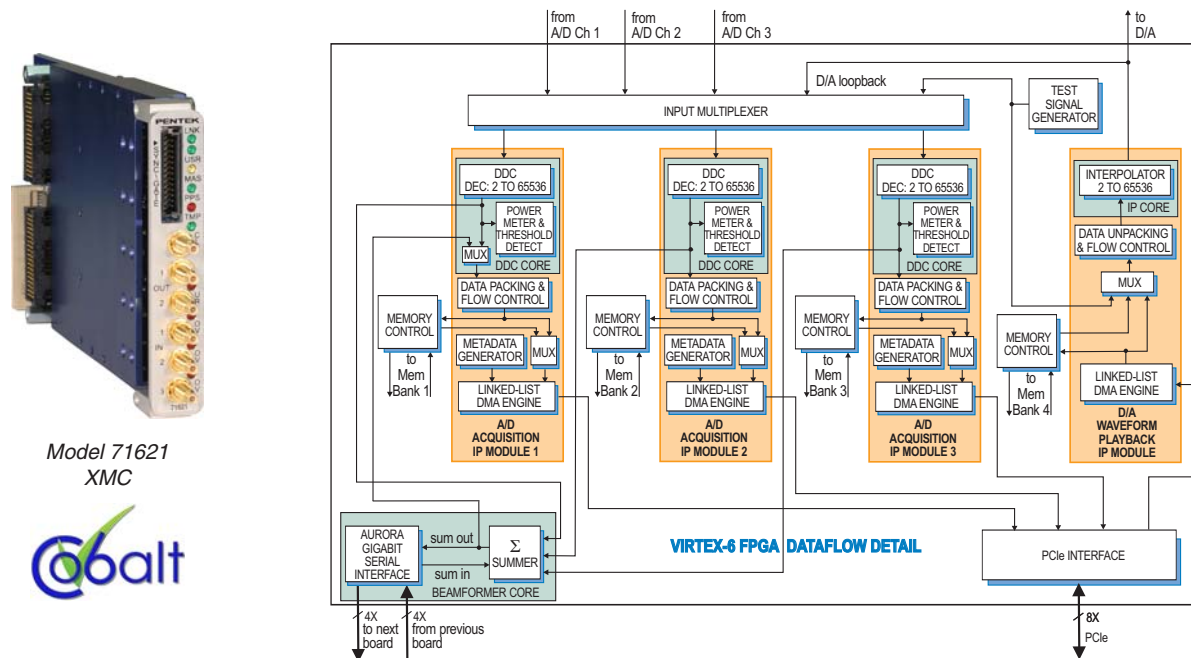

Figure 28

Model 71621 is a member of the Cobalt family of high performance XMC modules based on the Xilinx Virtex-6 FPGA. A multichannel, high-speed data converter based on the Model 71620 described in the previous page, it includes factory-installed IP cores to enhance the performance of the 71620 and address the requirements of many applications.

The 71621 factory-installed functions include three A/D acquisition and one D/A waveform playback IP modules. Each of the three acquisition IP modules contains a powerful, programmable DDC IP core. The waveform playback IP module contains an interpolation IP core, ideal for matching playback rates to the data and decimation rates of the acquisition modules. IP modules for either DDR3 or QDRII+ memories, a controller for all data clocking and synchronization functions, a test signal generator, an Aurora gigabit serial interface, and a PCIe interface complete the factory-installed functions.

Each DDC has an independent 32-bit tuning frequency setting that ranges from DC to f_s , where f_s is

the A/D sampling frequency. Each DDC can have its own unique decimation setting, supporting as many as three different output bandwidths for the board. Decimations can be programmed from 2 to 65,536 providing a wide range to satisfy most applications.

The 71621 also features a complete beamforming subsystem. Each DDC core contains programmable I & Q phase and gain adjustments followed by a power meter that continuously measures the individual average power output. The power meters present average power measurements for each DDC core output in easy-to-read registers. A threshold detector automatically sends an interrupt to the processor if the average power level of any DDC core falls below or exceeds a programmable threshold.

Versions of the 71621 are also available as a PCIe half-length board (Model 78621), 3U VPX (Models 52621 and 53621), AMC (Model 56621), 6U cPCI (Models 72621 and 74621 with dual density), and 3U cPCI (Model 73621).

Products

1 GHz A/D, 1 GHz D/A, Virtex-6 FPGA

**Model 78630 PCIe • Model 71630 XMC • Model 52630 3U VPX • Model 53630 3U VPX
Model 56630 AMC • Model 72630 6U cPCI • Model 73630 3U cPCI • Model 74630 6U cPCI**

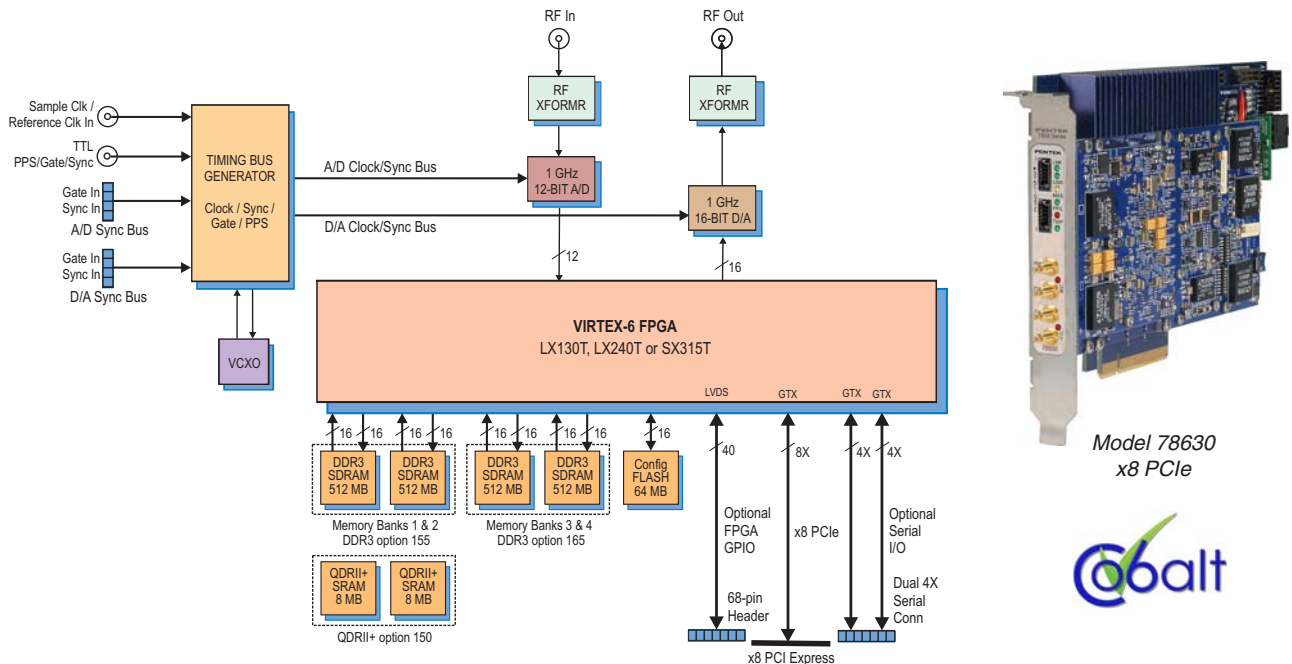

Model 78630
x8 PCIe



Figure 29

Model 78630 is a member of the Cobalt family of high performance PCIe boards based on the Xilinx Virtex-6 FPGA. A high-speed data converter, it is suitable for connection to HF or IF ports of a communications or radar system. Its built-in data capture and playback features offer an ideal turnkey solution as well as a platform for developing and deploying custom FPGA processing IP. It includes 1 GHz, 12-bit A/D, 1 GHz, 16-bit D/A converters and four banks of memory. In addition to supporting PCI Express Gen. 2 as a native interface, the Model 78630 includes optional general purpose and gigabit serial card connectors for application-specific I/O protocols.

The Pentek Cobalt architecture features a Virtex-6 FPGA. All of the board's data and control paths are accessible by the FPGA, enabling factory-installed functions including data multiplexing, channel selection, data packing, gating, triggering and memory control. The Cobalt architecture organizes the FPGA as a container for data processing applications where each function exists as an intellectual property (IP) module.

Each member of the Cobalt family is delivered with factory-installed applications ideally matched to the board's analog interfaces. The 78630 factory-installed functions include an A/D acquisition and a D/A waveform playback IP module. In addition, IP modules for either DDR3 or QDRII+ memories, a controller for all data clocking and synchronization functions, a test signal generator and a PCIe interface complete the factory-installed functions.

Multiple 78630's can be driven from the LVPECL bus master, supporting synchronous sampling and sync functions across all connected boards. The architecture supports up to four memory banks which can be configured with all QDRII+ SRAM, DDR3 SDRAM, or as combination of two banks of each type of memory.

Versions of the 78630 are also available as an XMC module (Model 71630), 3U VPX (Models 52630 and 53630), AMC (Model 56630), 6U cPCI (Models 72630 and 74630 with dual density), and 3U cPCI (Model 73630).

Products

1- or 2-Channel 3.6 GHz and 2- or 4-Channel 1.8 GHz, 12-bit A/D, Virtex-6 FPGA

**Model 72640 6U cPCI • Model 73640 3U cPCI • Model 74640 6U cPCI • Model 71640 XMC
Model 78640 PCIe • Model 52640 3U VPX • Model 53640 3U VPX • Model 56640 AMC**

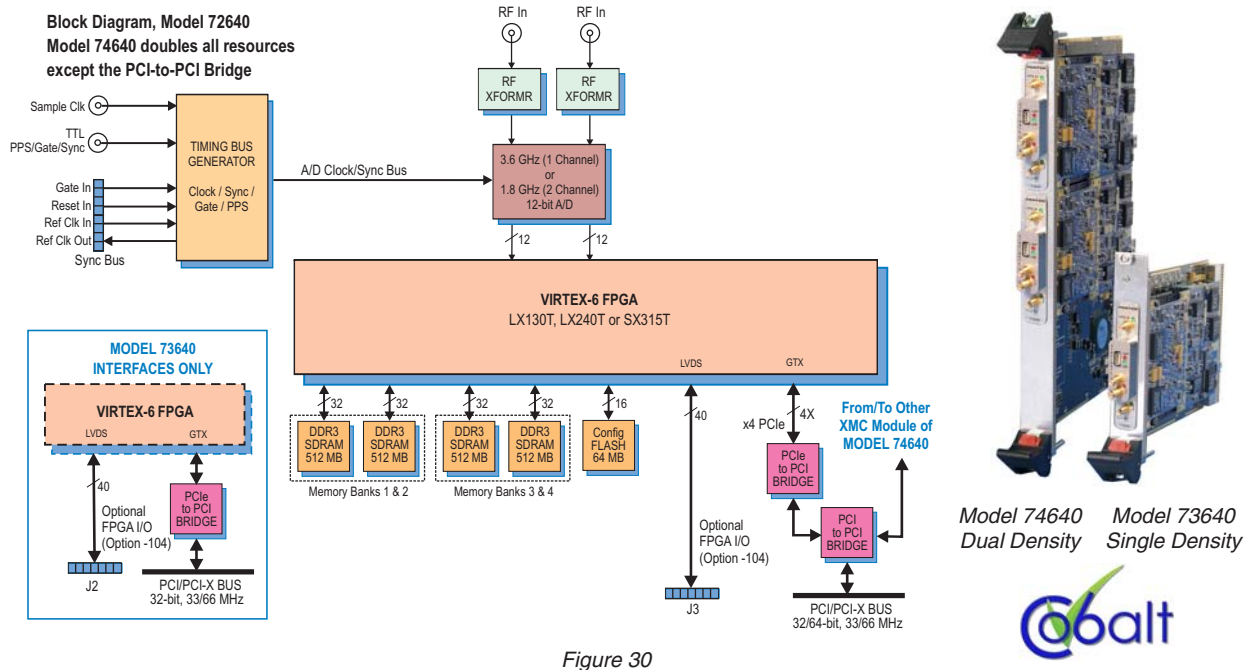

Figure 30

Models 72640, 73640 and 74640 are members of the Cobalt family of high performance CompactPCI boards based on the Xilinx Virtex-6 FPGA. They consist of one or two Model 71640 XMC modules mounted on a cPCI carrier board. These models include one or two 3.6 GHz, 12-bit A/D converters and four or eight banks of memory.

The Pentek Cobalt architecture features a Virtex-6 FPGA. All of the board's data and control paths are accessible by the FPGA, enabling factory-installed functions including data multiplexing, channel selection, data packing, gating, triggering and memory control. The Cobalt architecture organizes the FPGA as a container for data processing applications where each function exists as an intellectual property (IP) module.

Each member of the Cobalt family is delivered with factory-installed applications ideally matched to the board's analog interfaces. The factory-installed functions of these models include one or two A/D acquisition IP

modules. In addition, IP modules for DDR3 memories, controllers for all data clocking and synchronization functions, a test signal generator and a PCIe interface complete the factory-installed functions.

The front end accepts analog HF or IF inputs on a pair of front panel SSMC connectors with transformer coupling into a Texas Instruments ADC12D1800 12-bit A/D. The converter operates in single-channel interleaved mode with a sampling rate of 3.6 GHz and an input bandwidth of 1.75 GHz; or, in dual-channel mode with a sampling rate of 1.8 GHz and input bandwidth of 2.8 GHz. The ADC12D1800 provides a programmable 15-bit gain adjustment allowing these models to have a full scale input range of +2 dBm to +4 dBm.

Model 72640 is a 6U cPCI board, while Model 73640 is a 3U cPCI board; Model 74640 is a dual density 6U cPCI board. Also available is an XMC module (Model 71640), PCIe half-length board (Model 78640), 3U VPX (Models 52640 and 53640), and AMC (Model 56640).

Products

1- or 2-Channel 3.6 GHz and 2- or 4-Channel 1.8 GHz, 12-bit A/D, Wideband DDC, Virtex-6 FPGA

**Model 56641 AMC • Model 71641 XMC • Model 78641 PCIe • Model 52641 3U VPX
Model 53641 3U VPX • Model 72641 6U cPCI • Model 73641 3U cPCI • Model 74641 6U cPCI**

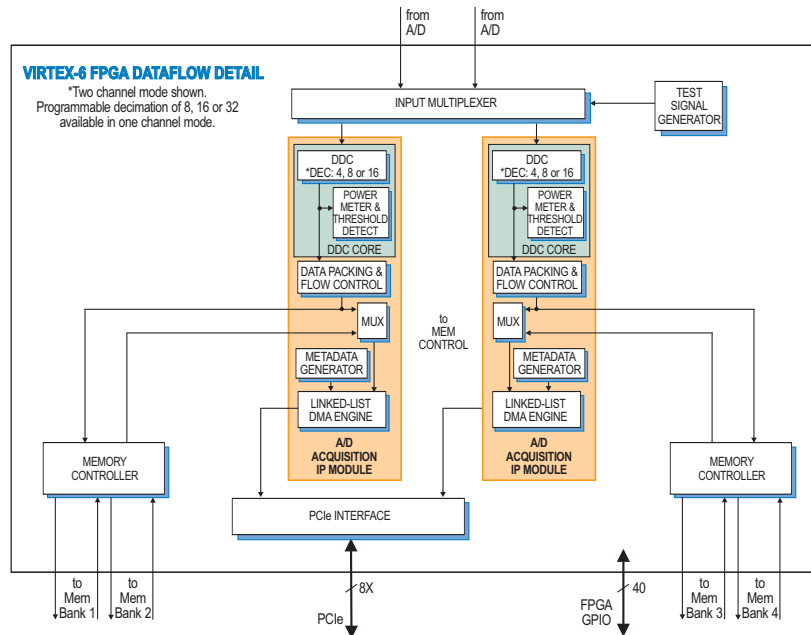

Model 56641
AMC



Figure 31

Model 56621 is a member of the Cobalt family of high performance AMC modules based on the Xilinx Virtex-6 FPGA. A very high-speed data converter based on the Model 56640 described in the previous page, it includes additional factory-installed IP cores to enhance the performance of the 56640 and address the requirements of many applications.

The 56641 factory-installed functions include an A/D acquisition IP module. In addition, within the FPGA is a powerful factory-installed DDC IP core. The core supports a single-channel mode, accepting data samples from the A/D at the full 3.6 GHz rate. Additionally, a dual-channel mode supports the A/D's 1.8 GHz two-channel operation .

In dual-channel mode, each DDC has an independent 32-bit tuning frequency setting that ranges from DC to f_s , where f_s is the A/D sampling frequency.

In single-channel mode, decimation can be programmed to 8x, 16x or 32x. In dual-channel mode, both channels share the same decimation rate, programmable to 4x, 8x or 16x.

The decimating filter for each DDC accepts a unique set of user-supplied 16-bit coefficients. The 80% default filters deliver an output bandwidth of $0.8 \cdot f_s / N$, where N is the decimation setting. The rejection of adjacent-band components within the 80% output bandwidth is better than 100 dB. Each DDC delivers a complex output stream consisting of 16-bit I + 16-bit Q samples at a rate of f_s / N .

Versions of the 56641 are also available as an XMC module (Model 71641), PCIe half-length board (Model 78641), 3U VPX (Models 52641 and 53641), 6U cPCI (Models 72641 and 74641 dual density), and 3U cPCI (Model 73641).

Products

2-Channel 500 MHz A/D, DUC, 2-Channel 800 MHz D/A, Virtex-6 FPGA

Model 52650 3U VPX • Model 53650 3U VPX • Model 71650 XMC • Model 78650 PCIe • Model 56650 AMC • Model 72650 6U cPCI • Model 73650 3U cPCI • Model 74650 6U cPCI

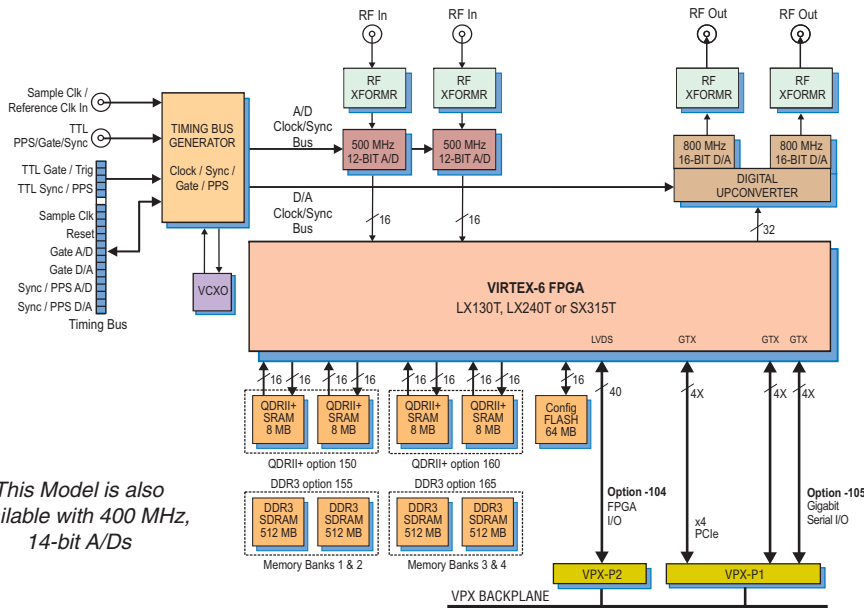

This Model is also available with 400 MHz, 14-bit A/Ds



Model 52650 3U VPX COTS and rugged



Figure 32

Model 52650 is a member of the Cobalt family of high performance 3U VPX boards based on the Xilinx Virtex-6 FPGA. A two-channel, high-speed data converter, it is suitable for connection to HF or IF ports of a communications or radar system. Its built-in data capture and playback features offer an ideal turnkey solution as well as a platform for developing and deploying custom FPGA processing IP. The 52650 includes two 500 MHz 12-bit A/Ds, one DUC, two 800 MHz 16-bit D/As and four banks of memory. It features built-in support for PCI Express over the 3U VPX backplane.

The Pentek Cobalt architecture features a Virtex-6 FPGA. All of the board's data and control paths are accessible by the FPGA, enabling factory-installed functions including data multiplexing, channel selection, data packing, gating, triggering and memory control. The Cobalt architecture organizes the FPGA as a container for data processing applications where each function exists as an intellectual property (IP) module.

Each member of the Cobalt family is delivered with factory-installed applications ideally matched to the board's analog interfaces. The 52650 factory-installed functions include an A/D acquisition and a D/A waveform playback IP module. In addition, IP modules for either DDR3 or QDRII+ memories, a controller for all data clocking and synchronization functions, a test signal generator and a PCIe interface complete the factory-installed functions.

Multiple 52650's can be driven from the LVPECL bus master, supporting synchronous sampling and sync functions across all connected boards. The architecture supports up to four memory banks which can be configured with all QDRII+ SRAM, DDR3 SDRAM, or as combination of two banks of each type of memory.

Versions of the 52650 are also available as a 3U VPX (Model 53650), XMC module (Model 71650), as a PCIe board (Model 78650), AMC (Model 56650), 6U cPCI (Models 72650 and 74650 dual density), and 3U cPCI (Model 73650).

Products

2- or 4-Channel 500 MHz A/D, with DDCs, DUCs, 2- or 4-Channel 800 MHz D/A, Virtex-6 FPGA

**Model 72651 6U cPCI • Model 73651 3U cPCI • Model 74651 6U cPCI • Model 52651 3U VPX
Model 53651 3U VPX • Model 71651 XMC • Model 78651 PCIe • Model 56651 AMC**

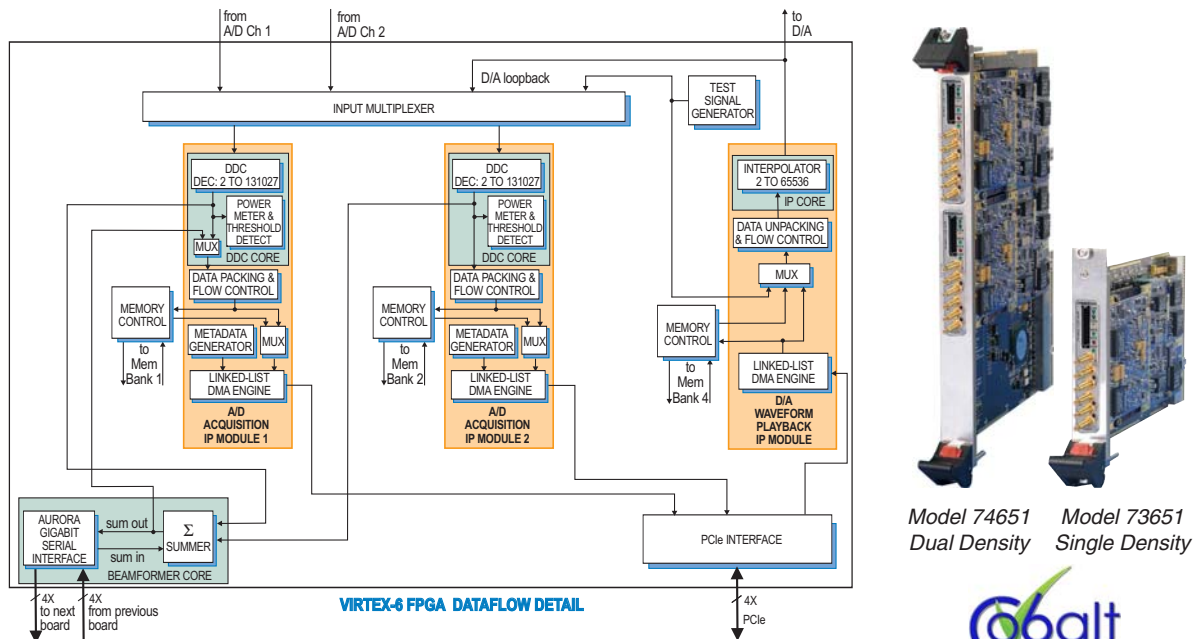

Model 74651 Dual Density Model 73651 Single Density



Figure 33

Models 72651, 73651 and 74651 are members of the Cobalt family of high performance CompactPCI boards based on the Xilinx Virtex-6 FPGA. They consist of one or two Model 71651 XMC modules mounted on a cPCI carrier board. These models include two or four A/Ds, two or four multiband DDCs, one or two DUCs, two or four D/As and three or six banks of memory.

These models feature two or four A/D Acquisition IP modules for easily capturing and moving data. Each module can receive data from either of the two A/Ds, a test signal generator or from the D/A Waveform Playback IP module in loopback mode.

Within each A/D Acquisition IP Module is a powerful DDC IP core. Because of the flexible input routing of the A/D Acquisition IP Modules, many different configurations can be achieved including one A/D driving both DDCs or each of the two A/Ds driving its own DDC.

Each DDC has an independent 32-bit tuning frequency setting that ranges from DC to f_s , where f_s is

the A/D sampling frequency. Each DDC can have its own unique decimation setting, supporting as many as two or four different output bandwidths for the board. Decimations can be programmed from 2 to 131,072 providing a wide range to satisfy most applications.

In addition to the DDCs, these models feature one or two complete beamforming subsystems. Each DDC core contains programmable I & Q phase and gain adjustments followed by a power meter that continuously measures the individual average power output. The time constant of the averaging interval for each meter is programmable up to 8K samples. The power meters present average power measurements for each DDC core output in easy-to-read registers.

Model 72651 is a 6U cPCI board, while Model 73651 is a 3U cPCI board; Model 74651 is a dual density 6U cPCI board. Also available is an XMC module (Model 71651), PCIe half-length board (Model 78651), 3U VPX (Models 52651 & 53651), and AMC (Model 56651).

Products

4-Channel 200 MHz 16-bit A/D with Virtex-6 FPGA

**Model 71660 XMC • Model 78660 PCIe • Model 52660 3U VPX • Model 53660 3U VPX
Model 56660 AMC • Model 72660 6U cPCI • Model 73660 3U cPCI • Model 74660 6U cPCI**

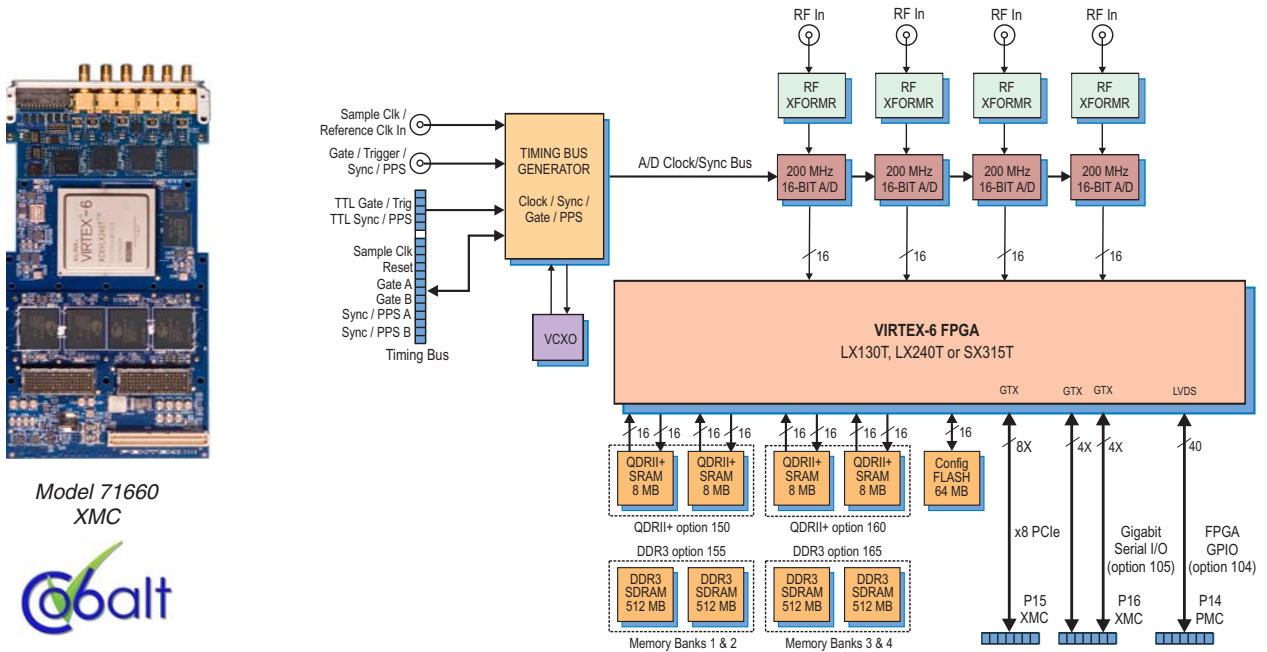

Figure 34

Model 71660 is a member of the Cobalt family of high performance XMC modules based on the Xilinx Virtex-6 FPGA. A multichannel, high-speed data converter, it is suitable for connection to HF or IF ports of a communications or radar system. Its built-in data capture and playback features offer an ideal turnkey solution as well as a platform for developing and deploying custom FPGA processing IP. It includes four 200 MHz, 16-bit A/Ds and four banks of memory. In addition to supporting PCI Express Gen. 2 as a native interface, the Model 71660 includes general purpose and gigabit serial connectors for application-specific I/O .

The Pentek Cobalt architecture features a Virtex-6 FPGA. All of the board's data and control paths are accessible by the FPGA, enabling factory-installed functions including data multiplexing, channel selection, data packing, gating, triggering and memory control. The Cobalt architecture organizes the FPGA as a container for data processing applications where each function exists as an intellectual property (IP) module.

Each member of the Cobalt family is delivered with factory-installed applications ideally matched to the board's analog interfaces. The 71660 factory-installed functions include four A/D acquisition IP modules. In addition, IP modules for either DDR3 or QDRII+ memories, a controller for all data clocking and synchronization functions, a test signal generator and a PCIe interface complete the factory-installed functions.

Multiple 71660's can be driven from the LVPECL bus master, supporting synchronous sampling and sync functions across all connected modules. The architecture supports up to four memory banks which can be configured with all QDRII+ SRAM, DDR3 SDRAM, or as combination of two banks of each type of memory.

Versions of the 71660 are also available as a PCIe half-length board (Model 78660), 3U VPX (Models 52660 and 53660), AMC (Model 56660), 6U cPCI (Models 72660 and 74660 with dual density), and 3U cPCI (Model 73660).

Products

4-Channel 200 MHz, 16-bit A/D with Virtex-7 FPGA

**Model 71760 XMC • Model 78760 PCIe • Model 52760 3U VPX • Model 53760 3U VPX
Model 56760 AMC • Model 72760 6U cPCI • Model 73760 3U cPCI • Model 74760 6U cPCI**

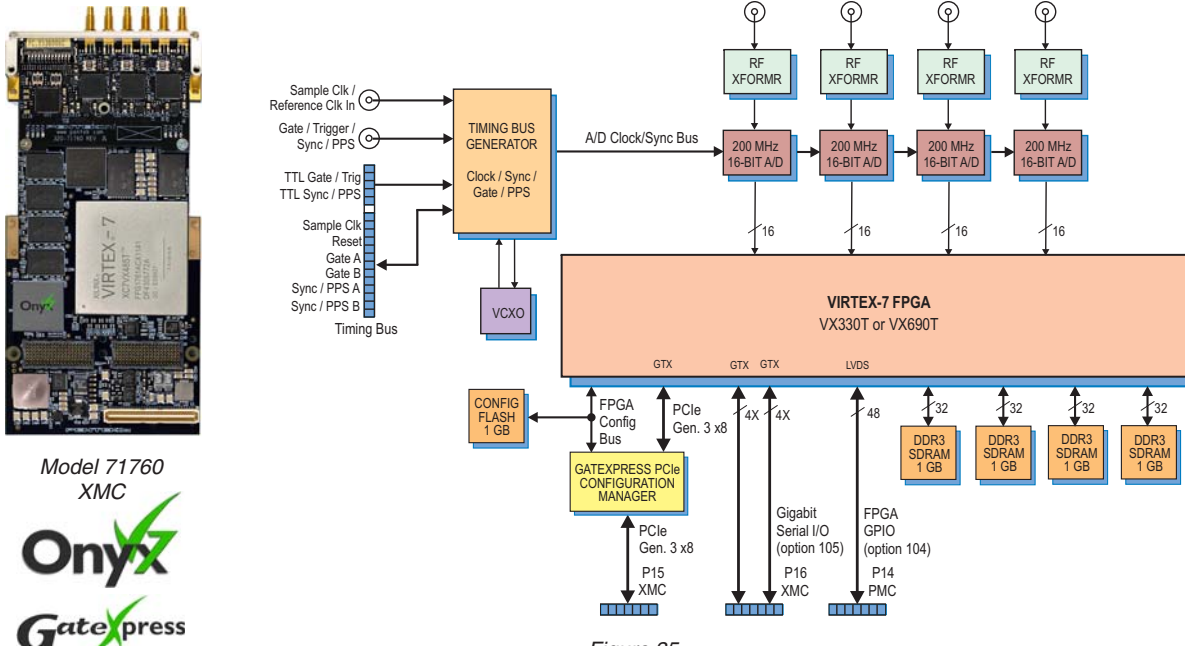

Figure 35

Model 71760 is a member of the Onyx family of high performance XMC modules based on the Xilinx Virtex-7 FPGA. A multichannel, high-speed data converter, it is suitable for connection to HF or IF ports of a communications or radar system. Its built-in data capture features offer an ideal turnkey solution as well as a platform for developing and deploying custom FPGA processing IP. It includes four A/Ds and four banks of memory. In addition to supporting PCI Express Gen. 3 as a native interface, the Model 71760 includes general purpose and gigabit serial connectors for application-specific I/O.

Based on the proven design of the Pentek Cobalt family, Onyx raises the processing performance with the new flagship family of Virtex-7 FPGAs from Xilinx. As the central feature of the board architecture, the FPGA has access to all data and control paths, enabling factory-installed functions including data multiplexing, channel selection, data packing, gating, triggering and memory control. The Onyx Architecture organizes the FPGA as a container for data processing applications where each function exists as an intellectual property (IP) module.

Each member of the Onyx family is delivered with factory-installed applications ideally matched to the board's analog interfaces. The 71760 factory-installed functions include four A/D acquisition IP modules for simplifying data capture and data transfer. IP modules for DDR3 SDRAM memories, a controller for all data clocking and synchronization functions, a test signal generator, and a PCIe interface complete the factory-installed functions.

The 71760 architecture supports four independent DDR3 SDRAM memory banks. Each bank is 1 GB deep and is an integral part of the module's DMA capabilities, providing FIFO memory space for creating DMA packets. Built-in memory functions include multichannel A/D data capture, tagging and streaming.

Versions of the 71760 are also available as a PCIe half-length board (Model 78760), 3U VPX (Models 52760 and 53760), AMC (Model 56760), 6U cPCI (Models 72760 and 74760 dual density), and 3U cPCI (Model 73760).

Please go to page 25 for information about GateXpress.

Products

4-Channel 200 MHz 16-bit A/D with Installed IP Cores, Virtex-6 FPGA

**Model 71661 XMC • Model 78661 PCIe • Model 52661 3U VPX • Model 53661 3U VPX
Model 56661 AMC • Model 72661 6U cPCI • Model 73661 3U cPCI • Model 74661 6U cPCI**

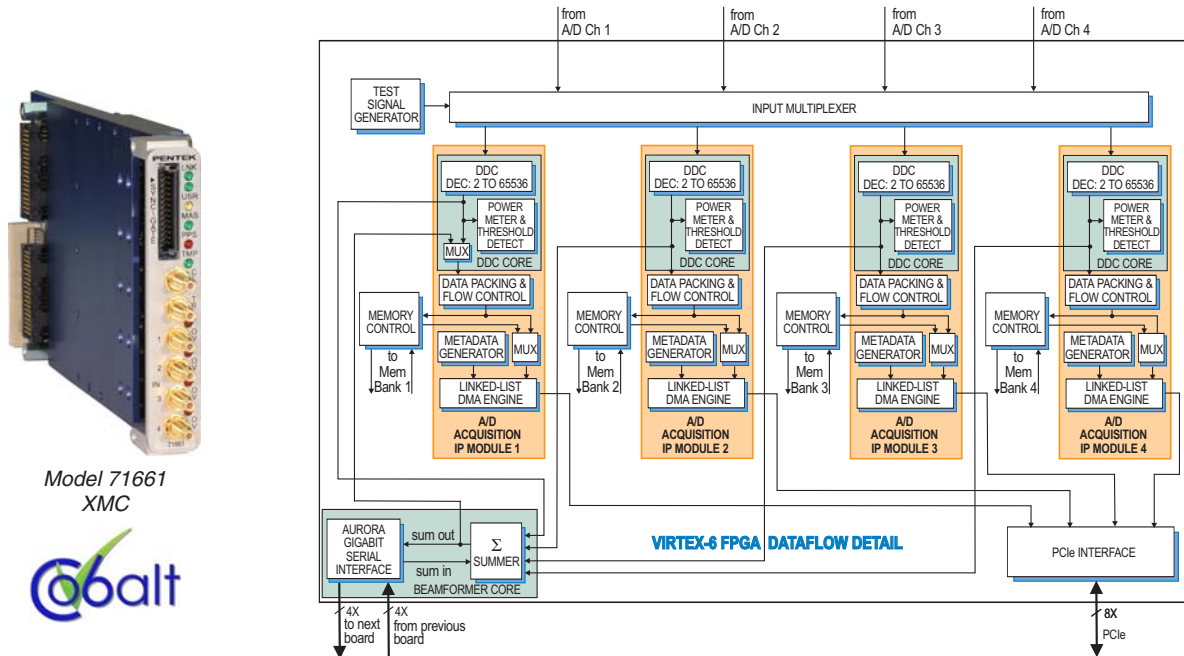

Figure 36



Model 71661
XMC



Model 71661 is a member of the Cobalt family of high performance XMC modules based on the Xilinx Virtex-6 FPGA. A multichannel, high-speed data converter based on the Model 71660 described in the previous page, it includes factory-installed IP cores to enhance the performance of the 71620 and address the requirements of many applications.

The 71661 factory-installed functions include four A/D acquisition IP modules. Each of the four acquisition IP modules contains a powerful, programmable DDC IP core. IP modules for either DDR3 or QDR II+ memories, a controller for all data clocking and synchronization functions, a test signal generator, an Aurora gigabit serial interface, and a PCIe interface complete the factory-installed functions.

Each DDC has an independent 32-bit tuning frequency setting that ranges from DC to f_s , where f_s is the A/D sampling frequency. Each DDC can have its own unique decimation setting, supporting as many as four different output bandwidths for the board. Decima-

tions can be programmed from 2 to 65,536 providing a wide range to satisfy most applications.

The 71661 also features a complete beamforming subsystem. Each DDC core contains programmable I & Q phase and gain adjustments followed by a power meter that continuously measures the individual average power output. The power meters present average power measurements for each DDC core output in easy-to-read registers. A threshold detector automatically sends an interrupt to the processor if the average power level of any DDC core falls below or exceeds a programmable threshold.

For larger systems, multiple 71661's can be chained together via the built-in Xilinx Aurora gigabit serial interface through the P16 XMC connector.

Versions of the 71661 are also available as a PCIe half-length board (Model 78661), 3U VPX (Models 52661 and 53661), AMC (Model 56661), 6U cPCI (Models 72661 and 74661 with dual density), and 3U cPCI (Model 73661).

Products

4-Channel 200 MHz 16-bit A/D with Installed IP Cores, Virtex-6 FPGA

**Model 78662 PCIe • Model 71662 XMC • Model 52662 3U VPX • Model 53662 3U VPX
Model 56662 AMC • Model 72662 6U cPCI • Model 73662 3U cPCI • Model 74662 6U cPCI**

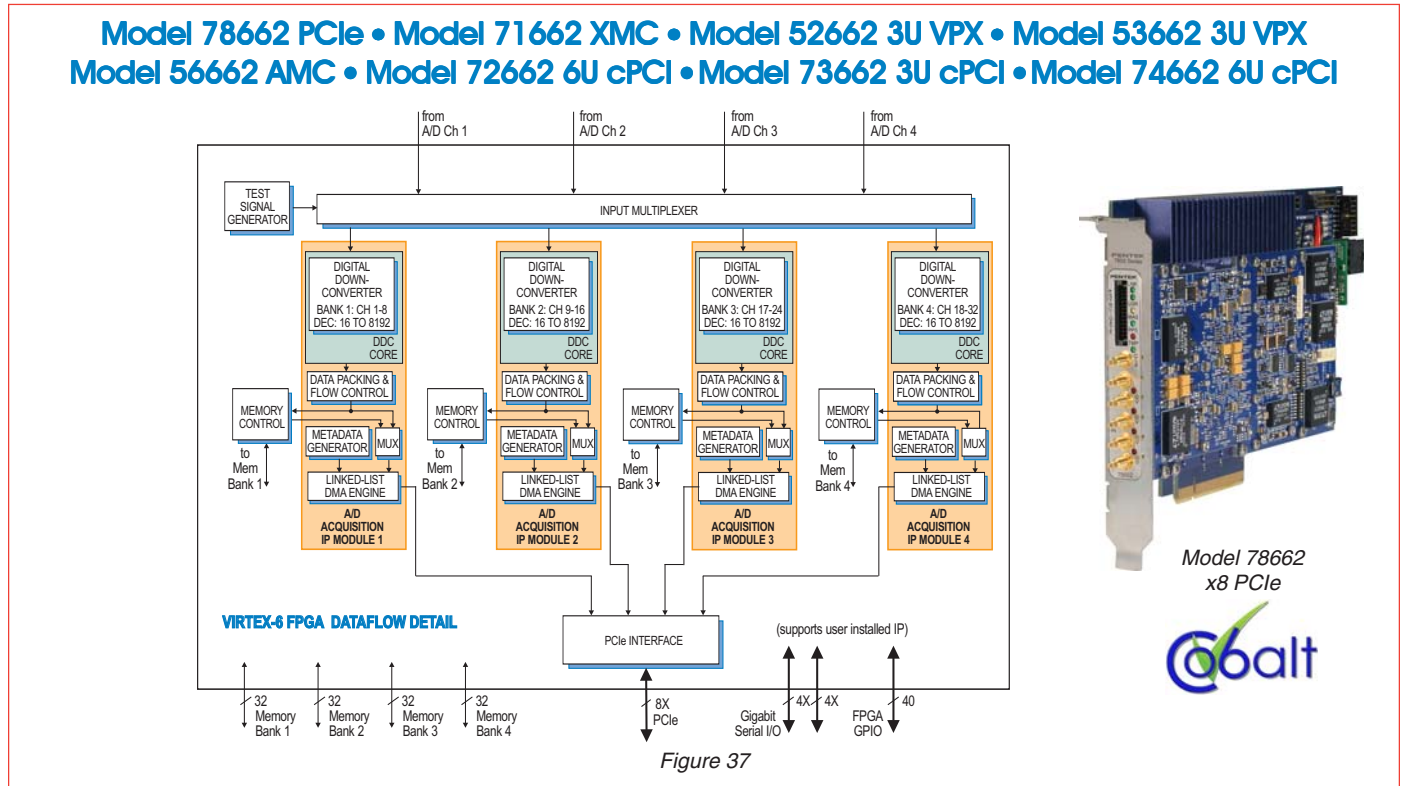

Model 78662 is a member of the Cobalt family of high performance PCIe boards based on the Xilinx Virtex-6 FPGA. Based on the Model 71660 presented previously, this four-channel, high-speed data converter with programmable DDCs is suitable for connection to HF or IF ports of a communications or radar system.

The 78662 factory-installed functions include four A/D acquisition IP modules. Each of the four acquisition IP modules contains a powerful, programmable 8-channel DDC IP core. IP modules for either DDR3 or QDRII+ memories, a controller for all data clocking and synchronization functions, a test signal generator, voltage and temperature monitoring, and a PCIe interface complete the factory-installed functions.

Each of the 32 DDC channels has an independent 32-bit tuning frequency setting that ranges from DC to f_s , where f_s is the A/D sampling frequency. All of the 8 channels within a bank share a common decimation setting ranging from 16 to 8192 programmable in steps

of eight. Each 8-channel bank can have its own unique decimation setting supporting a different bandwidth associated with each of the four acquisition modules.

The decimating filter for each DDC bank accepts a unique set of user-supplied 18-bit coefficients. The 80% default filters deliver an output bandwidth of $0.8 \cdot f_s / N$, where N is the decimation setting. The rejection of adjacent-band components within the 80% output bandwidth is better than 100 dB.

Each DDC delivers a complex output stream consisting of 24-bit I + 24-bit Q samples at a rate of f_s / N . Any number of channels can be enabled within each bank, selectable from 0 to 8. Multiple 78662's can be driven from the LVPECL bus master, supporting synchronous sampling and sync functions across all connected boards.

Versions of the 78662 are also available as an XMC module (Model 71662), 3U VPX (Models 52662 & 53662), AMC (Model 56662), 6U cPCI (Models 72662 and 74662 with dual density), and 3U cPCI (Model 73662).

Products

4-Channel 1.25 GHz D/A with DUC, Virtex-6 FPGA

**Model 56670 AMC • Model 71670 XMC • Model 78670 PCIe • Model 52670 3U VPX
Model 53670 3U VPX • Model 72670 6U cPCI • Model 73670 3U cPCI • Model 74670 6U cPCI**

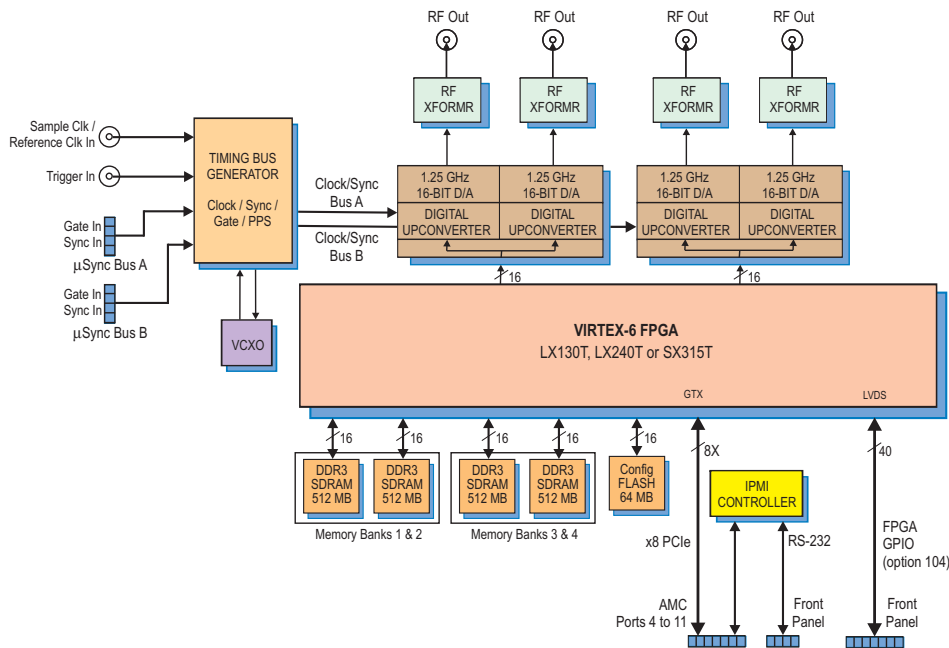

Model 56670
AMC



Figure 38

Model 56670 is a member of the Cobalt family of high performance AMC modules based on the Xilinx Virtex-6 FPGA. This 4-channel, high-speed data converter is suitable for connection to transmit HF or IF ports of a communications or radar system. Its built-in data playback features offer an ideal turnkey solution for demanding transmit applications. It includes four D/As, four digital upconverters and four banks of memory. In addition to supporting PCI Express Gen. 2 as a native interface, the Model 56670 includes a front panel general-purpose connector for application-specific I/O.

The Pentek Cobalt Architecture features a Virtex-6 FPGA. All of the board's data and control paths are accessible by the FPGA, enabling factory-installed functions including data multiplexing, channel selection, data packing, gating, triggering and memory control. The Cobalt Architecture organizes the FPGA as a container for data processing applications where each function exists as an intellectual property (IP) module.

Each member of the Cobalt family is delivered with factory-installed applications ideally matched to the board's analog interfaces. The 56670 factory-installed functions include four D/A waveform playback IP modules, to support waveform generation through the D/A converters. IP modules for DDR3 SDRAM memories, a controller for all data clocking and synchronization functions, a test signal generator, and a PCIe interface complete the factory-installed functions and enable the 56670 to operate as a complete turnkey solution, without the need to develop any FPGA IP.

The Model 56670 factory-installed functions include a sophisticated D/A Waveform Playback IP module. Four linked-list controllers support waveform generation to the four D/As from tables stored in either on-board memory or off-board host memory.

Versions of the 56670 are available as an XMC (Model 71670), PCIe half-length board (Model 78670), 3U VPX (Models 52670 and 53670), 6U cPCI (Models 72670 and 74670 dual density), and 3U cPCI (Model 73670).

Products

4-Channel 1.25 GHz D/A with DUC, Extended Interpolation, Virtex-6 FPGA

**Model 71671 XMC • Model 78671 PCIe • Model 52671 3U VPX • Model 53671 3U VPX
Model 56671 AMC • Model 72671 6U cPCI • Model 73671 3U cPCI • Model 74671 6U cPCI**

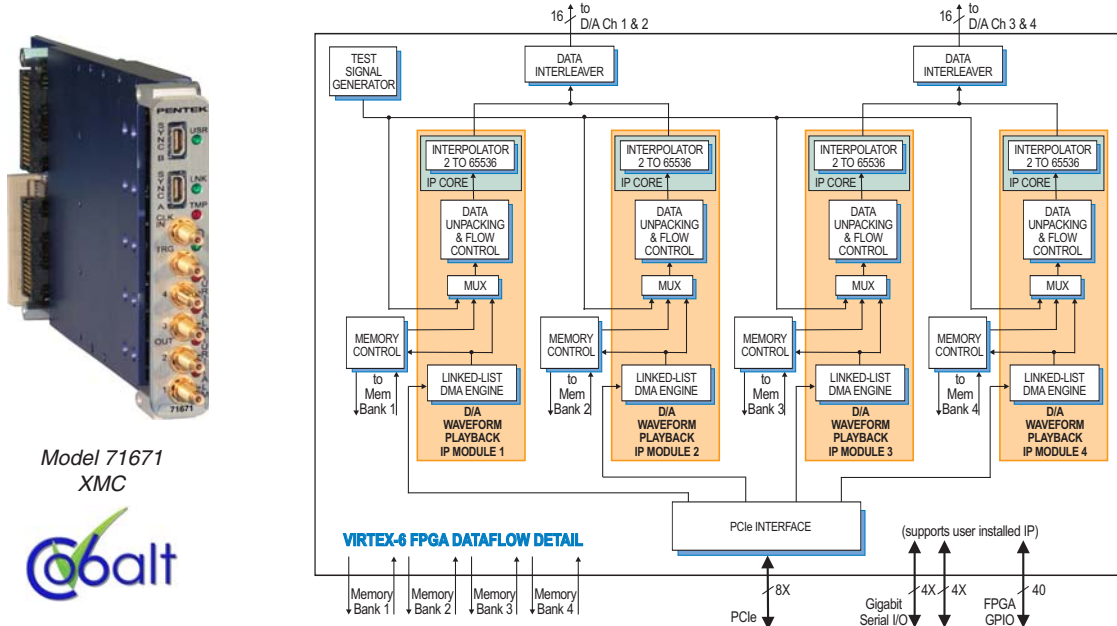

Figure 39



Model 71671
XMC



Model 71671 is a member of the Cobalt family of high performance XMC modules based on the Xilinx Virtex-6 FPGA. A multichannel, high-speed data converter based on the Model 71670 described in the previous page, it includes factory-installed IP cores to enhance the performance of the 71670 and address the requirements of many applications.

The Model 56671 factory-installed functions include a sophisticated D/A Waveform Playback IP module. Four linked-list controllers support waveform generation to the four D/As from tables stored in either on-board memory or off-board host memory.

Two Texas Instruments DAC3484s provide four DUC (digital upconverter) and D/A channels. Each channel accepts a baseband real or complex data stream from the FPGA and provides that input to the upconvert, interpolate and D/A stage.

When operating as a DUC, it interpolates and translates real or complex baseband input signals to a user

selectable IF center frequency. It delivers real or quadrature (I+Q) analog outputs to a 16-bit D/A converter.

If translation is disabled, each D/A acts as an interpolating 16-bit D/A with output sampling rates up to 1.25 GHz. In both modes, the D/A provides interpolation factors of 2x, 4x, 8x and 16x.

In addition to the DAC3484, the 71671 features an FPGA-based interpolation engine which adds two additional interpolation stages programmable from 2x to 256x. The combined interpolation results in a range from 2x to 1,048,576x for each D/A channel and is ideal for matching the digital downconversion and data reduction used on the receiving channels of many communications systems.

Versions of the 71671 are also available as a PCIe half-length board (Model 78671), 3U VPX (Models 52671 and 53671), AMC (Model 56671), 6U cPCI (Models 72671 and 74671 with dual density), and 3U cPCI (Model 73671).

Products

L-Band RF Tuner with 2-Channel 200 MHz A/D and Virtex-6 FPGA

**Model 53690 3U VPX • Model 52690 3U VPX • Model 71690 XMC • Model 78690 PCIe
Model 56690 AMC • Model 72690 6U cPCI • Model 73690 3U cPCI • Model 74690 6U cPCI**

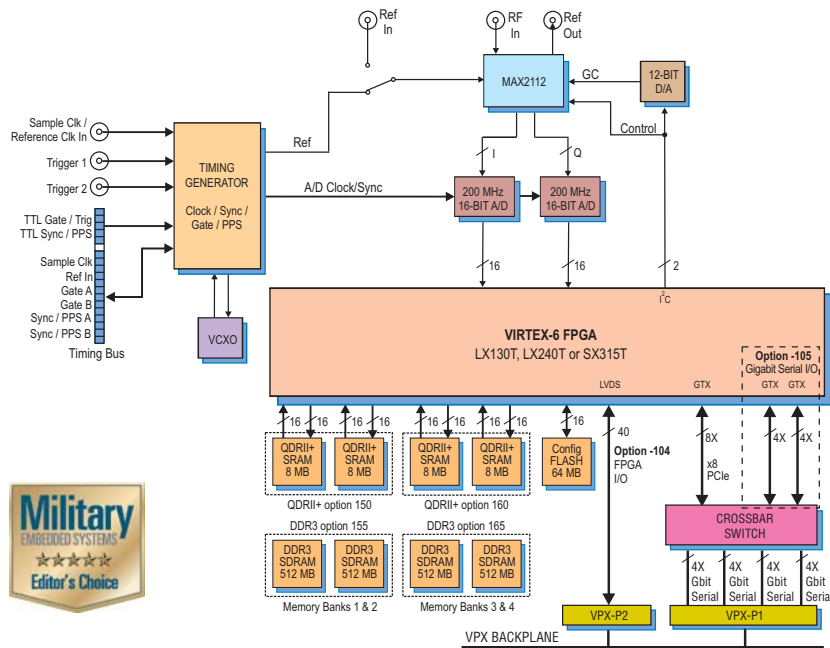

Model 53690 3U VPX
COTS and rugged



Figure 40

Model 53690 is a member of the Cobalt family of high performance 3U VPX boards based on the Xilinx Virtex-6 FPGA. A 2-Channel high-speed data converter, it is suitable for connection directly to the RF port of a communications or radar system. Its built-in data capture features offer an ideal turnkey solution. The Model 53690 includes an L-Band RF tuner, two 200 MHz, 16-bit A/Ds and four banks of memory. It features built-in support for PCI Express over the 3U VPX backplane.

The Pentek Cobalt architecture features a Virtex-6 FPGA. All of the board's data and control paths are accessible by the FPGA, enabling factory-installed functions including data multiplexing, channel selection, data packing, gating, triggering and memory control. The Cobalt architecture organizes the FPGA as a container for data processing applications where each function exists as an intellectual property (IP) module.

Each member of the Cobalt family is delivered with factory-installed applications ideally matched to the

board's analog interfaces. The 53690 factory-installed functions include two A/D acquisition IP modules. IP modules for either DDR3 or QDRII+ memories, a controller for all data clocking and synchronization functions, a test signal generator, and a PCIe interface complete the factory-installed functions.

A front panel connector accepts L-Band signals between 925 MHz and 2175 MHz from an antenna LNB. A Maxim MAX2112 tuner directly converts these signals to baseband using a broadband I/Q downconverter. The device includes an RF variable-gain LNA (low-noise amplifier), a PLL synthesized local oscillator, quadrature (I + Q) downconverting mixers, baseband lowpass filters and variable-gain baseband amplifiers.

Versions of the 53690 are also available as a 3U VPX (Model 52690), an XMC (Model 71690), as a PCIe (Model 78690), AMC (Model 56690), 6U cPCI (Models 72690 and 74690 with dual density), and 3U cPCI (Model 73690).

Products

2.2 GHz Clock, Sync and Gate Distribution Board

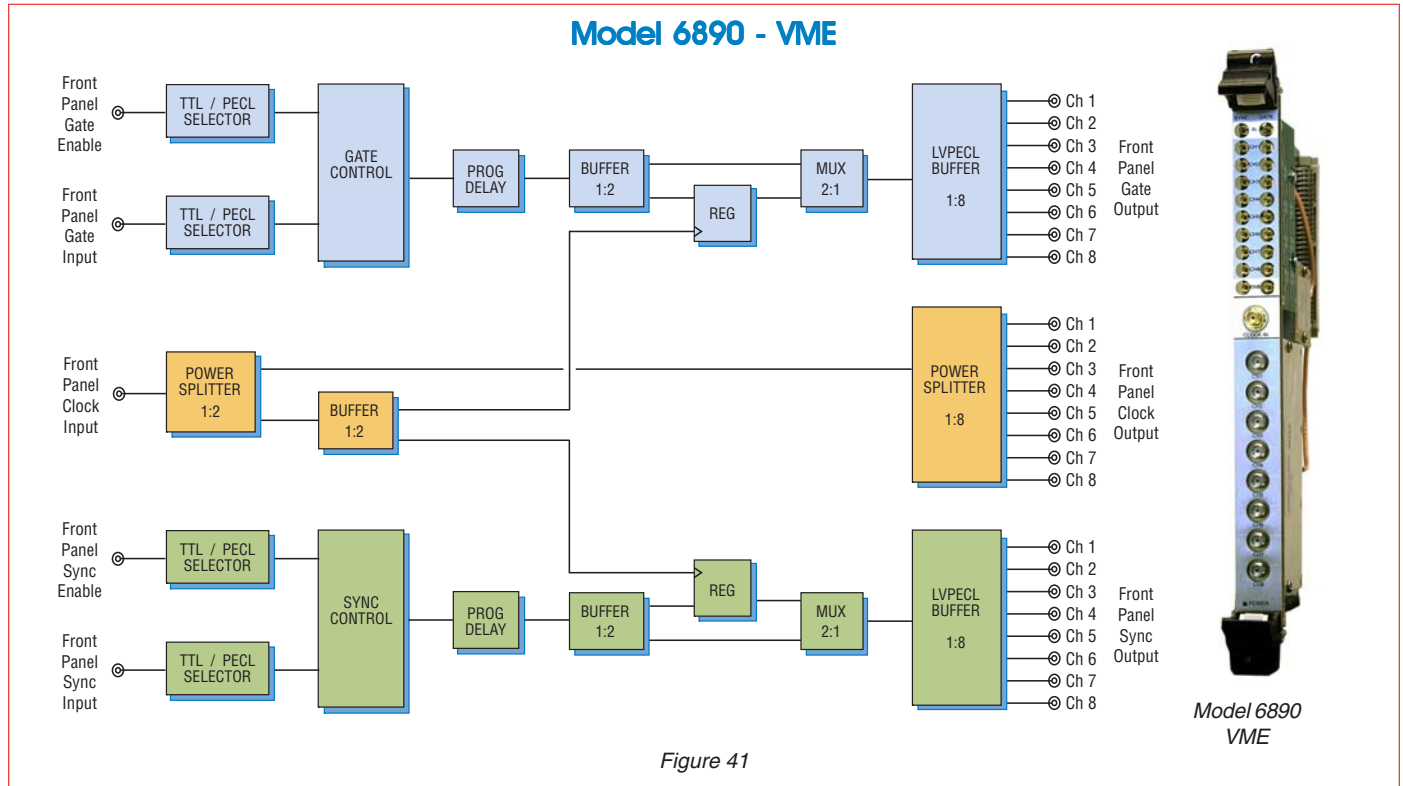

Model 6890 Clock, Sync and Gate Distribution Board synchronizes multiple Pentek I/O boards within a system. It enables synchronous sampling and timing for a wide range of multichannel high-speed data acquisition, DSP and software radio applications. Up to eight boards can be synchronized using the 6890, each receiving a common clock of up to 2.2 GHz along with timing signals that can be used for synchronizing, triggering and gating functions.

Clock signals are applied from an external source such as a high performance sine wave generator. Gate and sync signals can come from an external source, or from one supported board set to act as the master.

The 6890 accepts clock input at +10 dBm to +14 dBm with a frequency range from 800 MHz to 2.2 GHz and uses a 1:2 power splitter to distribute the clock. The first output of this power splitter sends the clock signal to a 1:8 splitter for distribution to up to eight boards using SMA connectors. The second output of the 1:2 power

splitter feeds a 1:2 buffer which distributes the clock signal to both the gate and synchronization circuits.

The 6890 features separate inputs for gate/trigger and sync signals with user-selectable polarity. Each of these inputs can be TTL or LVPECL. Separate Gate Enable and Sync Enable inputs allow the user to enable or disable these circuits using an external signal.

A programmable delay allows the user to make timing adjustments on the gate and sync signals before they are sent to an LVPECL buffer. A bank of eight MMCX connectors at the output of each buffer delivers signals to up to eight boards.

A 2:1 multiplexer in each circuit allows the gate/trigger and sync signals to be registered with the input clock signal before output, if desired.

Sets of input and output cables for two to eight boards are available from Pentek.

Products

System Synchronizer and Distribution Board

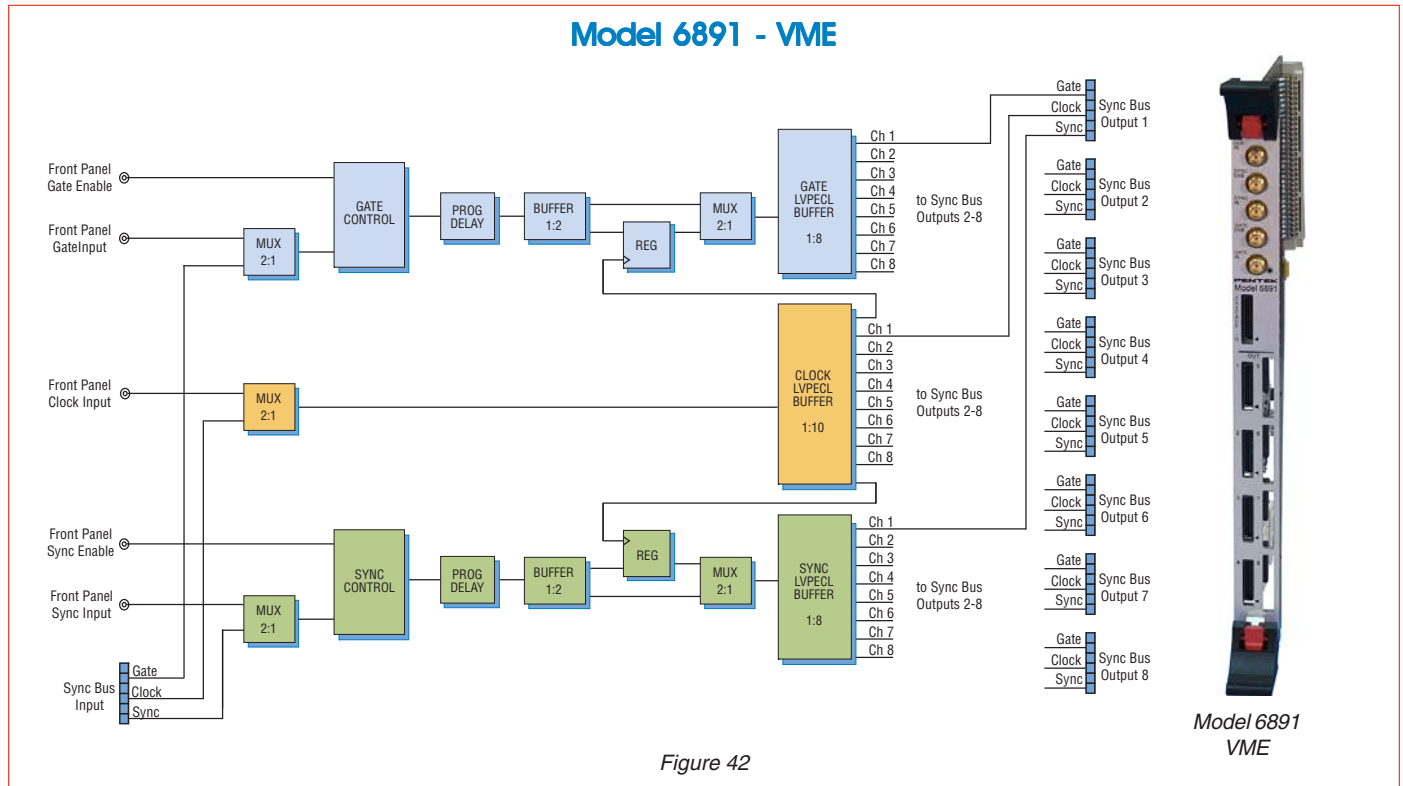

Model 6891 System Synchronizer and Distribution Board synchronizes multiple Pentek I/O modules within a system. It enables synchronous sampling and timing for a wide range of multichannel high-speed data acquisition, DSP and software radio applications.

Up to eight modules can be synchronized using the 6891, each receiving a common clock up to 500 MHz along with timing signals that can be used for synchronizing, triggering and gating functions. For larger systems, up to eight 6891's can be linked together to provide synchronization for up to 64 I/O modules producing systems with up to 256 channels.

Model 6891 accepts three TTL input signals from external sources: one for clock, one for gate or trigger and one for a synchronization signal. Two additional inputs are provided for separate gate and sync enable signals.

Clock signals can be applied from an external source such as a high performance sine-wave generator. Gate/trigger and sync signals can come from an external system source. Alternately, a Sync Bus connector accepts LVPECL inputs from any compatible Pentek products to drive the clock, sync and gate/trigger signals.

The 6891 provides eight front panel Sync Bus output connectors, compatible with a wide range of Pentek I/O modules. The Sync Bus is distributed through ribbon cables, simplifying system design. The 6891 accepts clock input at +10 dBm to +14 dBm with a frequency range from 1 kHz to 800 MHz. This clock is used to register all sync and gate/trigger signals as well as providing a sample clock to all connected I/O modules.

A programmable delay allows the user to make timing adjustments on the gate and sync signals before they are sent to an LVPECL buffer for output through the Sync Bus connectors.

Products

Multifrequency Clock Synthesizer

**Model 7190 PMC • Model 7290 6U cPCI • Model 7390 3U cPCI • Model 7690 PCI
Model 7790 Full-length PCIe • Model 7890 Half-length PCIe • Model 5390 3U VPX**

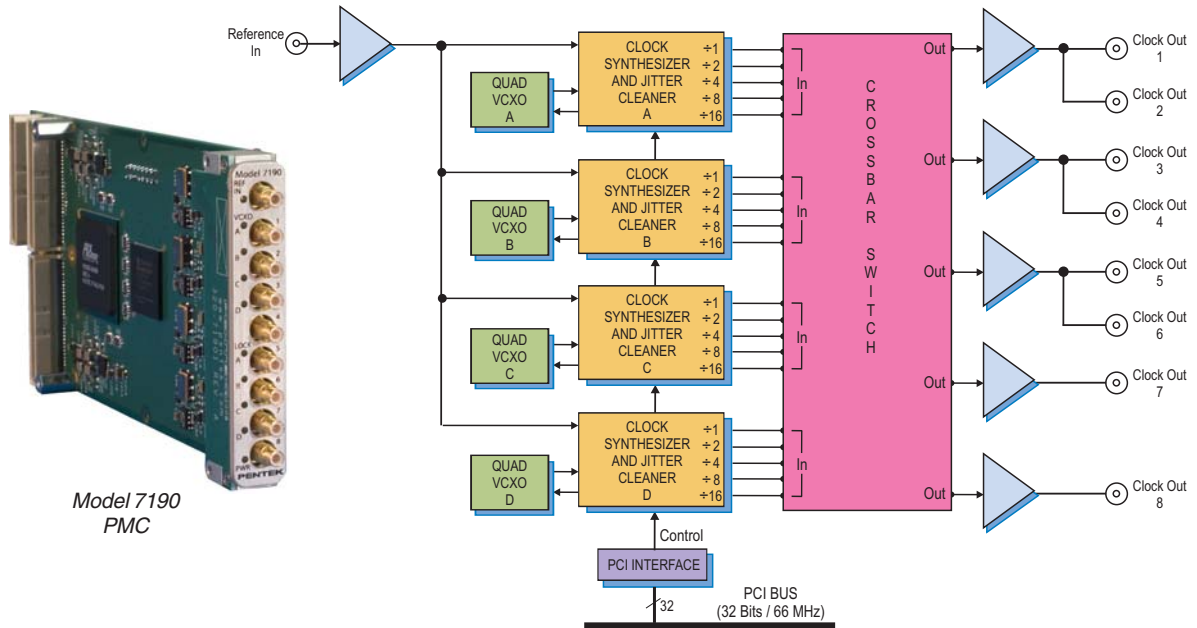

Figure 43

Model 7190 generates up to eight synthesized clock signals suitable for driving A/D and D/A converters in high-performance real-time data acquisition and software radio systems. The clocks offer exceptionally low phase noise and jitter to preserve the signal quality of the data converters. These clocks are synthesized from on-board quad VCXOs and can be phase-locked to an external reference signal.

The 7190 uses four Texas Instruments CDC7005 clock synthesizer and jitter cleaner devices. Each CDC7005 is paired with a dedicated VCXO to provide the base frequency for the clock synthesizer. Each of the four VCXOs can be independently programmed to generate one of four frequencies between 50 MHz and 700 MHz.

The CDC7005 can output the selected frequency of its associated VCXO, or generate submultiples using divisors of 2, 4, 8 or 16. The four CDC7005's can output up to five frequencies each. The 7190 can be programmed to route any of these 20 frequencies to the module's five output drivers.

The CDC7005 includes phase-locking circuitry that locks the frequency of its associated VCXO to an input reference of 5 MHz to 100 MHz.

Eight front panel SMC connectors supply synthesized clock outputs driven from the five clock output drivers. This supports a single identical clock to all eight outputs or up to five different clocks to various outputs. With four independent quad VCXOs and each CDC7005 capable of providing up to five different submultiple clocks, a wide range of clock configurations is possible. In systems where more than five different clock outputs are required simultaneously, multiple 7190's can be used and phase-locked with the 5 MHz to 100 MHz system reference.

Versions of the 7190 are also available as a PCIe full-length board (Models 7790 and 7790D dual density), PCIe half-length board (Model 7890), 3U VPX board (Model 5390), PCI board (Model 7690), 6U cPCI (Models 7290 and 7290D dual density), or 3U cPCI (Model 7390).

Products

Programmable Multifrequency Clock Synthesizer

**Model 7191 PMC • Model 7291 6U cPCI • Model 7391 3U cPCI • Model 7691 PCI
Model 7791 Full-length PCIe • Model 7891 Half-length PCIe • Model 5391 3U VPX**

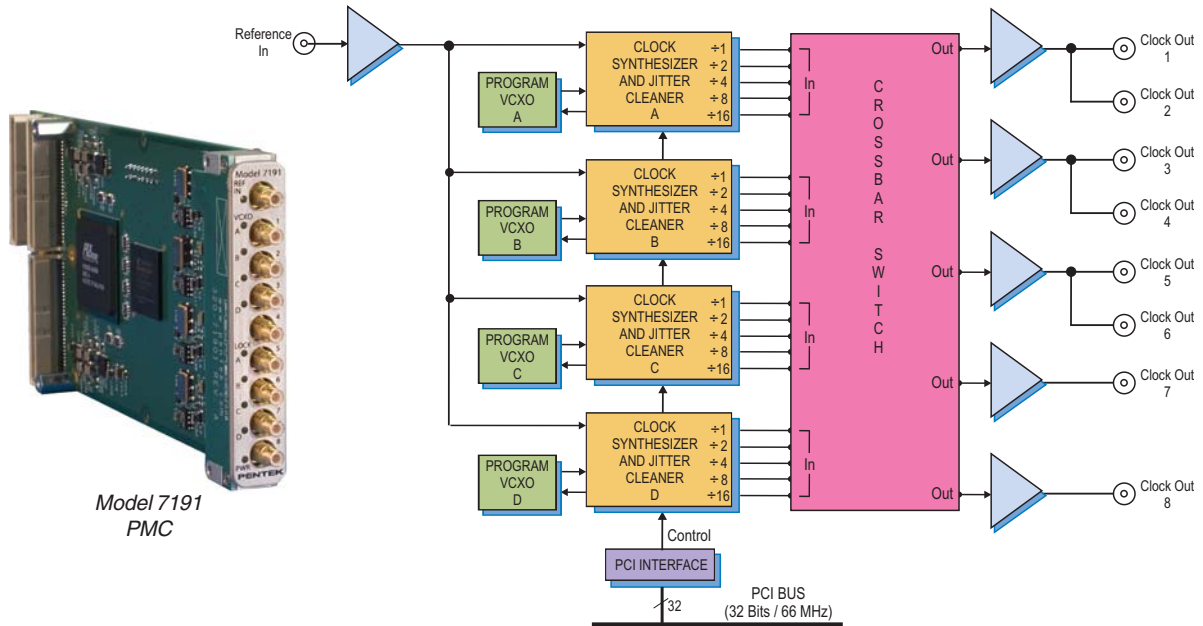

Figure 44

Model 7191 generates up to eight synthesized clock signals suitable for driving A/D and D/A converters in high-performance real-time data acquisition and software radio systems. The clocks offer exceptionally low phase noise and jitter to preserve the signal quality of the data converters. These clocks are synthesized from programmable VCXOs and can be phase-locked to an external reference signal.

The 7191 uses four Texas Instruments CDC7005 clock synthesizer and jitter cleaner devices. Each CDC7005 is paired with a dedicated VCXO to provide the base frequency for the clock synthesizer. Each of the four VCXOs can be independently programmed to a desired frequency between 50 MHz and 700 MHz with 32-bit tuning resolution.

The CDC7005 can output the programmed frequency of its associated VCXO, or generate submultiples using divisors of 2, 4, 8 or 16. The four CDC7005's can output up to five frequencies each. The 7191 can be programmed to route any of these 20 frequencies to the module's five output drivers.

The CDC7005 includes phase-locking circuitry that locks the frequency of its associated VCXO to an input reference of 5 MHz to 100 MHz.

Eight front panel SMC connectors supply synthesized clock outputs driven from the five clock output drivers. This supports a single identical clock to all eight outputs or up to five different clocks to various outputs. With four programmable VCXOs and each CDC7005 capable of providing up to five different submultiple clocks, a wide range of clock configurations is possible. In systems where more than five different clock outputs are required simultaneously, multiple 7191's can be used and phase-locked with the 5 MHz to 100 MHz system reference.

Versions of the 7191 are also available as a PCIe full-length board (Models 7791 and 7791D dual density), PCIe half-length board (Model 7891), 3U VPX board (Model 5391), PCI board (Model 7691), 6U cPCI (Models 7291 and 7291D dual density), or 3U cPCI (Model 7391).

Products

High-Speed Synchronizer and Distribution Board

**Model 7192 PMC/XMC • Model 7892 Half-length PCIe • Model 5292 3U VPX
Model 7292 6U cPCI • Model 7392 3U cPCI • Model 7492 6U cPCI**

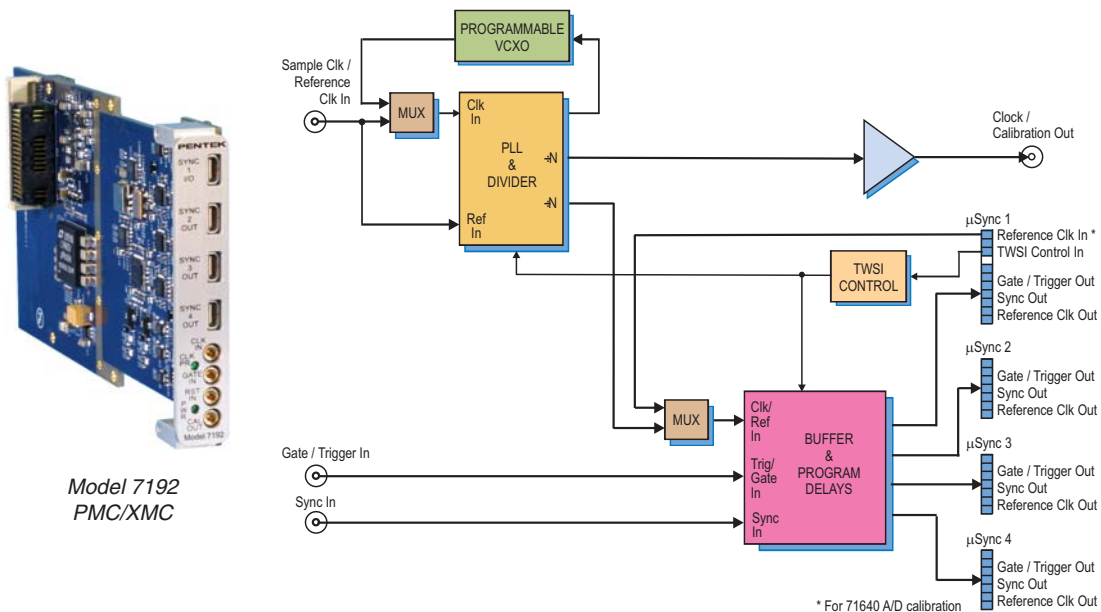

Model 7192
PMC/XMC

Figure 45

The Model 7192 High-Speed Synchronizer and Distribution Board synchronizes multiple Pentek Cobalt or Onyx modules within a system. It enables synchronous sampling and timing for a wide range of multichannel high-speed data acquisition, DSP, and software radio applications. Up to four modules can be synchronized using the 7192, with each receiving a common clock along with timing signals that can be used for synchronizing, triggering and gating functions.

Model 7192 provides three front panel MMCX connectors to accept input signals from external sources: one for clock, one for gate or trigger and one for a synchronization signal. Clock signals can be applied from an external source such as a high performance sine-wave generator. Gate/trigger and sync signals can come from an external system source. In addition to the MMCX connector, a reference clock can be accepted through the first front panel μ Sync output connector, allowing a single Cobalt or Onyx board to generate the clock for all subsequent boards in the system.

The 7192 provides four front panel μ Sync output connectors, compatible with a range of high-speed Pentek Cobalt and Onyx modules. The μ Sync signals include a reference clock, gate/trigger and sync signals and are distributed through matched cables, simplifying system design. The 7192 features a calibration output specifically designed to work with the 71640 or 71740 3.6 GHz A/D module and provide a signal reference for phase adjustment across multiple D/As.

The 7192 supports all high-speed models in the Cobalt family including the 71630 1 GHz A/D and D/A XMC, the 71640 3.6 GHz A/D XMC and the 71670 Four-channel 1.25 GHz, 16-bit D/A XMC. The 7192 will also support high-speed models in the Onyx family as they become available.

Versions of the 7192 are also available as a PCIe half-length board (Model 7892), 3U VPX (Model 5292), 6U cPCI (Models 7292 and 7492 dual density), and 3U cPCI (Model 7392).

Products

System Synchronizer and Distribution Board

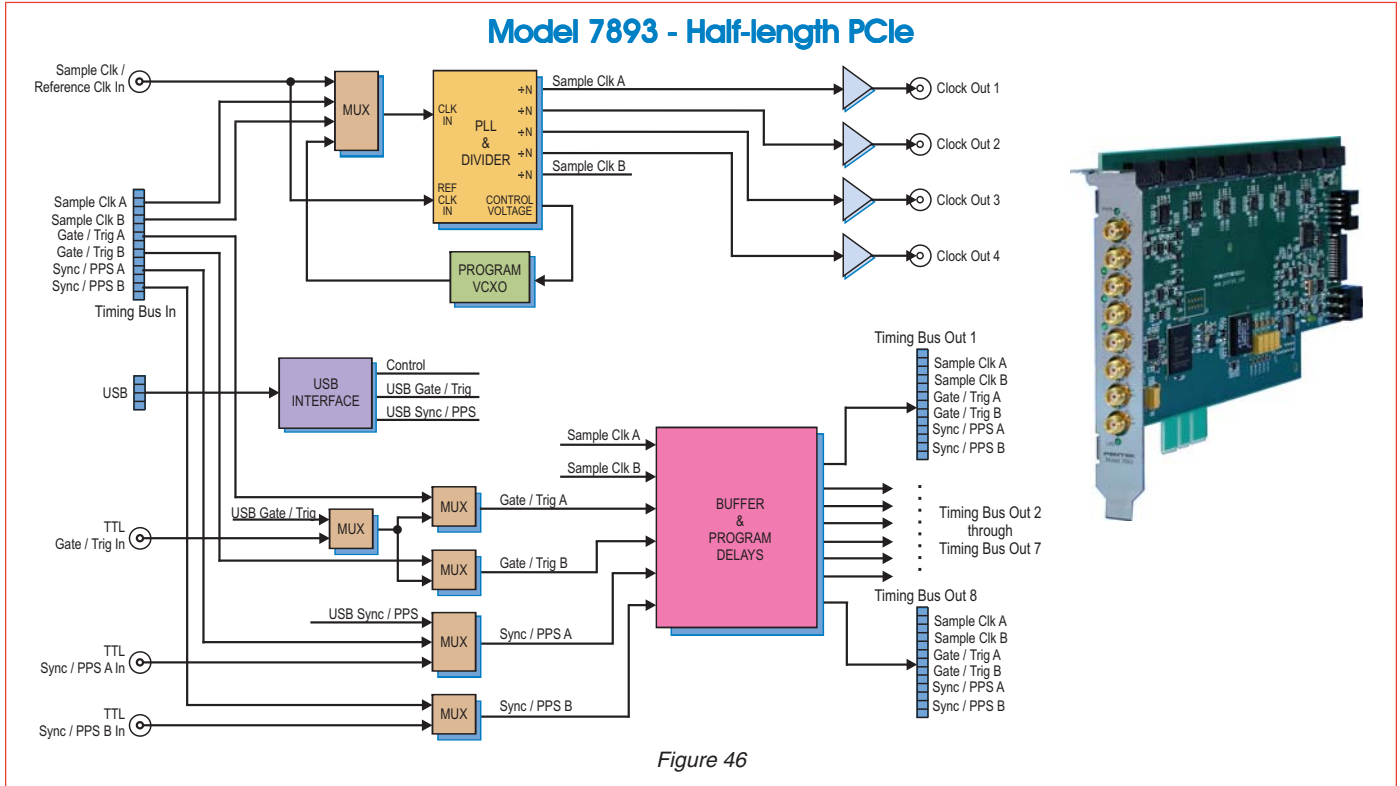

Model 7893 System Synchronizer and Distribution Board synchronizes multiple Pentek Cobalt and Onyx boards within a system. It enables synchronous sampling, playback and timing for a wide range of multichannel high-speed data acquisition, DSP and software radio applications.

Up to eight boards can be synchronized using the 7893, each receiving a common clock up to 800 MHz along with timing signals that can be used for synchronizing, triggering and gating functions. For larger systems, up to eight 7893s can be linked together to provide synchronization for up to 64 Cobalt or Onyx boards.

The Model 7893 provides four front panel SMA connectors to accept LVTTTL input signals from external sources: two for Sync/PPS and one for Gate/Trigger. In addition to the synchronization signals, a front panel SMA connector accepts sample clocks up to 800 MHz or, in an alternate mode, accepts a 10 MHz reference clock to lock an on-board VCXO sample clock source.

The 7893 provides eight timing bus output connectors for distributing all needed timing and clock signals to the front panels of Cobalt and Onyx boards via ribbon cables. The 7893 locks the Gate/Trigger and Sync/PPS signals to the system's sample clock. The 7893 also provides four front panel SMA connectors for distributing sample clocks to other boards in the system.

The 7893 can accept a clock from either the front panel SMA connector or from the timing bus input connector. A programmable on-board VCXO clock generator can be locked to a user-supplied, 10 MHz reference.

The 7893 supports a wide range of products in the Cobalt family including the 78620 and 78621 three-channel A/D 200 MHz transceivers, the 78650 and 78651 two-channel A/D 500 MHz transceivers, the 78660, 78661 and 78662 four-channel 200 MHz A/Ds, and the 78690 L-Band RF Tuner. The 7893 also supports the Onyx 78760 four-channel 200 MHz A/D and will support all complementary models in the Onyx family as they become available.

Products

High-Speed Clock Generator

**Model 7194 PMC/XMC • Model 7894 Half-length PCIe • Model 5294 3U VPX
 Model 5694 AMC • Model 7294 6U cPCI • Model 7394 3U cPCI • Model 7492 6U cPCI**

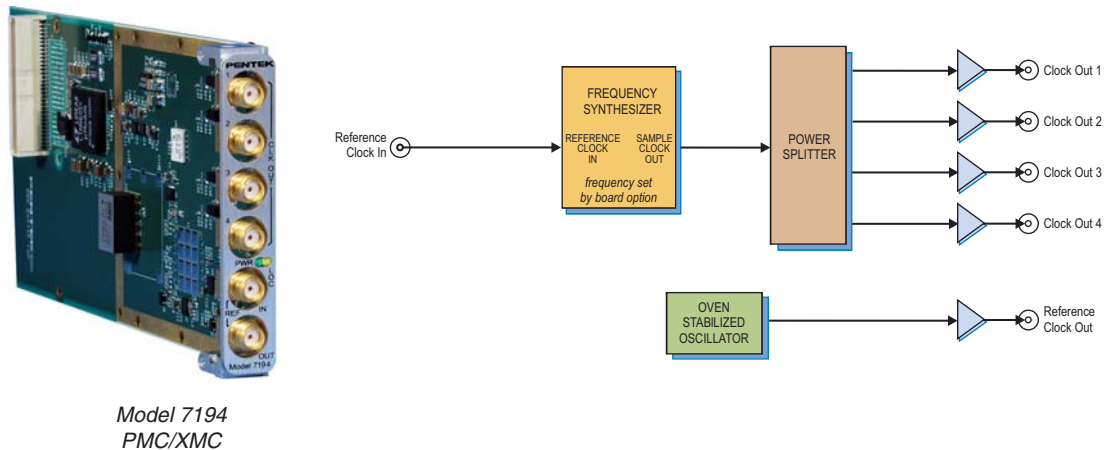

Figure 47

Model 7194 High-Speed Clock Generator provides fixed-frequency sample clocks to Cobalt and Onyx modules in multiboard systems. It enables synchronous sampling, playback and timing for a wide range of multichannel high-speed data acquisition and software radio applications.

The Model 7194 uses a high-precision, fixed-frequency, PLO (Phase-Locked Oscillator) to generate an output sample clock. The PLO accepts a 10 MHz reference clock through a front panel SMA connector. The PLO locks the output sample clock to the incoming reference. A power splitter then receives the sample clock and distributes it to four front panel SMA connectors.

The 7194 is available with sample clock frequencies from 1.4 to 2.0 GHz.

In addition to accepting a reference clock on the front panel, the 7194 includes an on-board 10 MHz reference clock. The reference is an OXCO (Oven-Controlled Crystal Oscillator), which provides an exceptionally precise frequency standard with excellent phase noise characteristics.

The 7194 is a standard PMC/XMC module. The module does not require programming and the PMC P14 or XMC P15 connector is used solely for power. The module can be optionally configured with a PCIe-style 6-pin power connector allowing it to be used in virtually any chassis or enclosure.

Versions of the 7194 are also available as a PCIe half-length board (Model 7894), 3U VPX (Model 5294), AMC (Model 5694), 6U cPCI (Models 7294 and 7494 dual density), and 3U cPCI (Model 7394).

Products

Clock and Sync Generator for I/O Modules

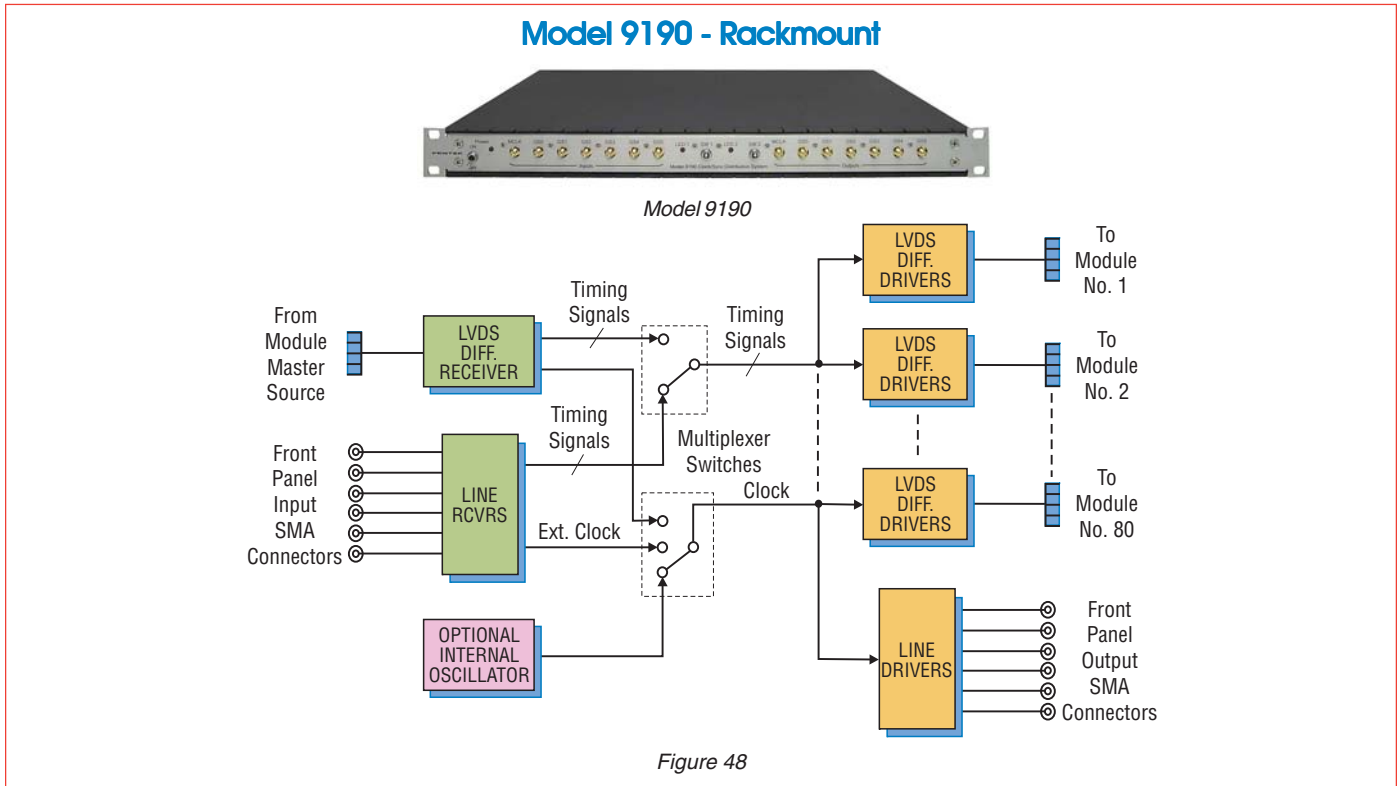

Model 9190 Clock and Sync Generator synchronizes multiple Pentek I/O modules within a system to provide synchronous sampling and timing for a wide range of high-speed, multichannel data acquisition, DSP and software radio applications. Up to 80 I/O modules can be driven from the Model 9190, each receiving a common clock and up to five different timing signals which can be used for synchronizing, triggering and gating functions.

Clock and timing signals can come from six front panel SMA user inputs or from one I/O module set to act as the timing signal master. (In this case, the master I/O module will not be synchronous with the slave modules due to delays through the 9190.) Alternately, the master clock can come from a socketed, user-replaceable crystal oscillator within the Model 9190.

Buffered versions of the clock and five timing signals are available as outputs on the 9190's front panel SMA connectors.

Model 9190 is housed in a line-powered, 1.75 in. high metal chassis suitable for mounting in a standard 19 in. equipment rack, either above or below the cage holding the I/O modules.

Separate cable assemblies extend from openings in the front panel of the 9190 to the front panel clock and sync connectors of each I/O module. Mounted between two standard rack-mount card cages, Model 9190 can drive a maximum of 80 clock and sync cables, 40 to the card cage above and 40 to the card cage below. Fewer cables may be installed for smaller systems.

Products

High-Speed System Synchronizer Unit

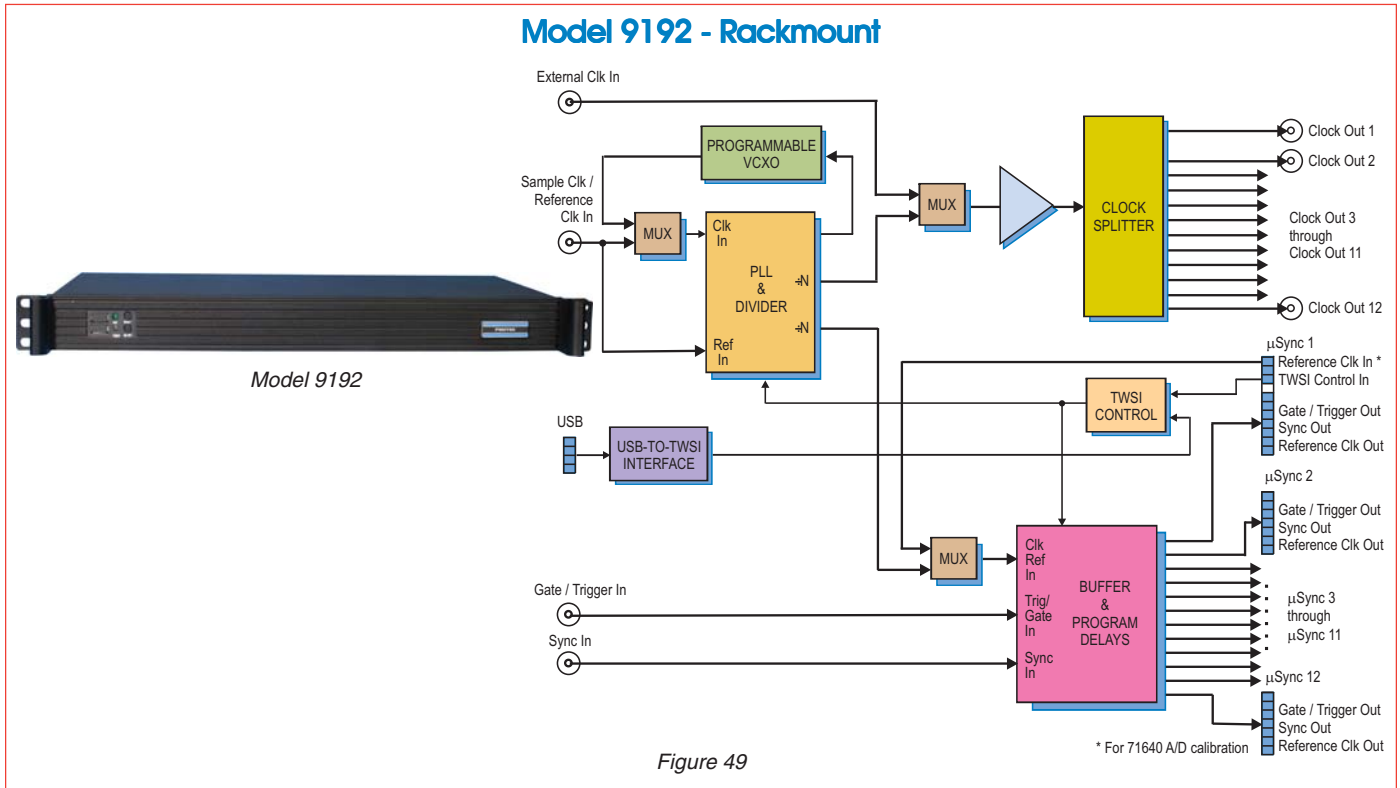

Model 9192 Rackmount High-Speed System Synchronizer Unit synchronizes multiple Pentek Cobalt or Onyx modules within a system. It enables synchronous sampling and timing for a wide range of multichannel high-speed data acquisition, DSP, and software radio applications. Up to twelve boards can be synchronized using the 9192, each receiving a common clock along with timing signals that can be used for synchronizing, triggering and gating functions.

Model 9192 provides four rear panel SMA connectors to accept input signals from external sources: two for clock, one for gate or trigger and one for a synchronization signal. Clock signals can be applied from an external source such as a high performance sine-wave generator. Gate/trigger and sync signals can come from an external system source. In addition to the SMA connector, a reference clock can be accepted through the first rear panel μ Sync output connector, allowing a single Cobalt or Onyx board to generate the clock for all subsequent boards in the system.

The 9192 provides four rear panel μ Sync output connectors, compatible with a range of high-speed Pentek Cobalt and Onyx boards. The μ Sync signals include a reference clock, gate/trigger and sync signals and are distributed through matched cables, simplifying system design.

The 9192 features twelve calibration outputs specifically designed to work with the 71640 or 71740 3.6 GHz A/D module and provide a signal reference for phase adjustment across multiple D/As.

The 9192 allows programming of operation parameters including: VCXO frequency, clock dividers, and delays that allow the user to make timing adjustments on the gate and sync signals. These adjustments are made before they are sent to buffers for output through the μ Sync connectors.

The 9192 supports all high-speed models in the Cobalt family including the 71630 1 GHz A/D and D/A XMC, the 71640 3.6 GHz A/D XMC and the 71670 Four-channel 1.25 GHz, 16-bit D/A XMC. The 9192 will also support high-speed models in the Onyx family as they become available.

Products

Eight-Channel RF/IF, 200 MS/sec Rackmount Recorder

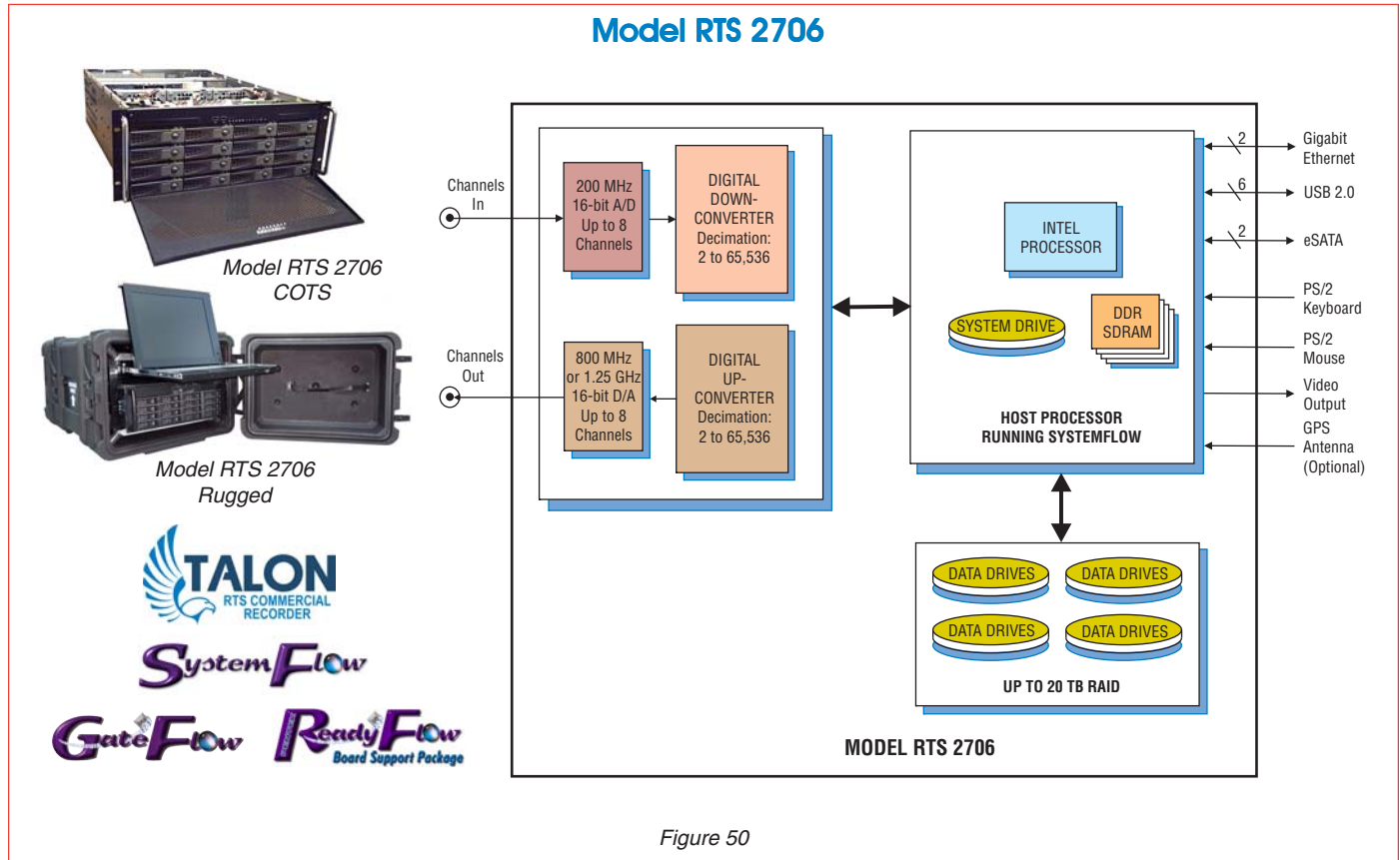

Figure 50

The Talon® RTS 2706 is a turnkey, multiband recording and playback system for recording and reproducing high-bandwidth signals. The RTS 2706 uses 16-bit, 200 MHz A/D converters and provides sustained recording rates up to 2.0 GB/sec in four-channel configuration.

The RTS 2706 uses Pentek's high-powered Virtex-6-based Cobalt modules, that provide flexibility in channel count, with optional digital downconversion capabilities. Optional 16-bit, 800 MHz D/A converters with digital upconversion allow real-time reproduction of recorded signals.

A/D sampling rate, DDC decimation and bandwidth, D/A sampling rate and DUC interpolation are among the GUI-selectable system parameters, providing a fully-programmable system capable of recording and reproducing a wide range of signals.

Included with this system is Pentek's SystemFlow recording software. Optional GPS time and position stamping allows the user to record this critical signal information.

Built on a Windows® 7 Professional workstation with high performance Intel® Core™ i7 processor, the RTS 2706 allows the user to install post-processing and analysis tools to operate on the recorded data. The instrument records data to the native NTFS file system, providing immediate access to the data.

The RTS 2706 is configured in a 4U 19" rackmountable chassis, with hot-swap data drives, front panel USB ports and I/O connectors on the rear panel. Systems are scalable to accommodate multiple chassis to increase channel counts and aggregate data rates. All recorder chassis are connected via Ethernet and can be controlled from a single GUI either locally or from a remote PC.

Products

Four-Channel RF/IF, 500 MS/sec Rackmount Recorder

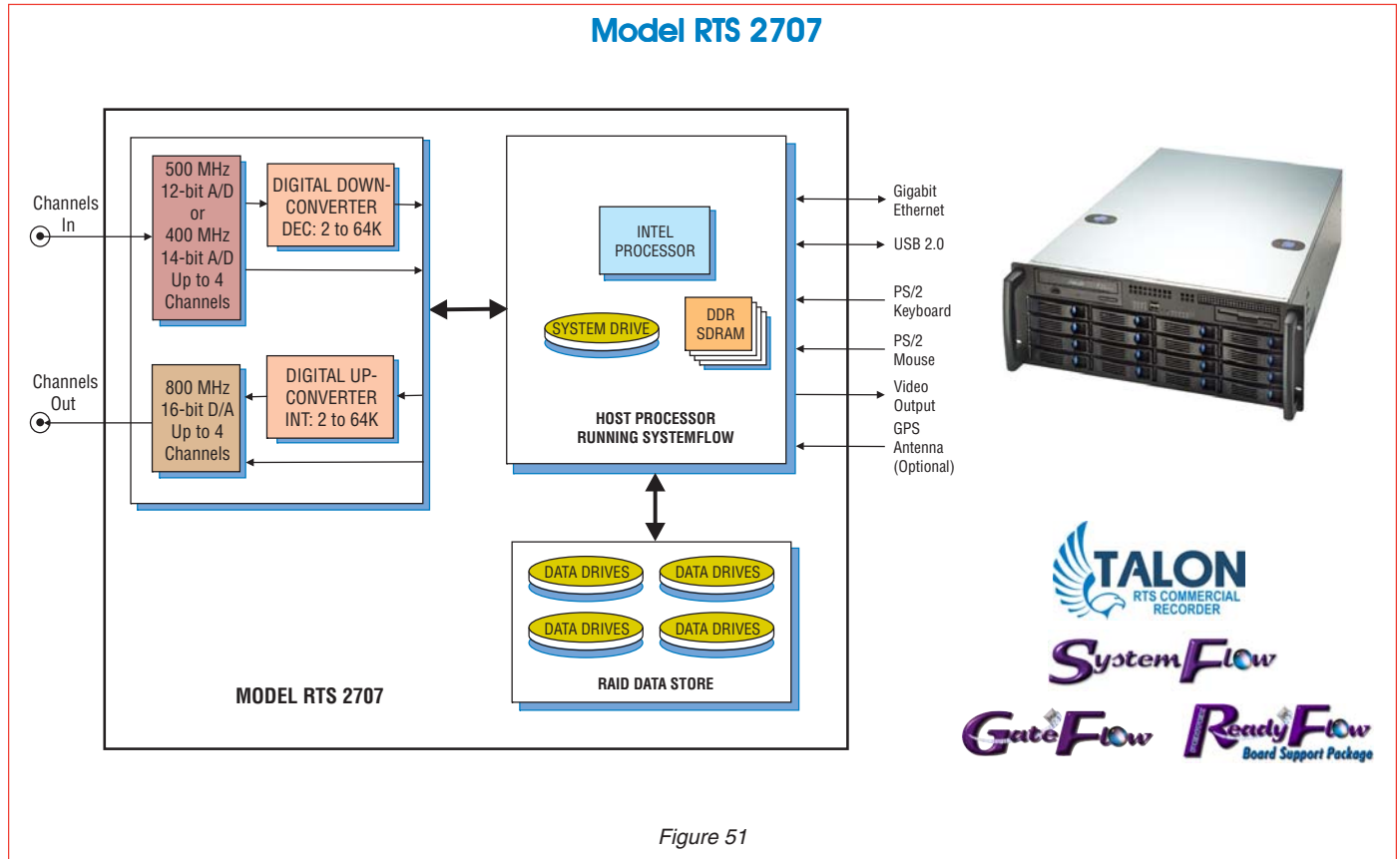

Figure 51

The Talon RTS 2707 is a turnkey, multiband recording and playback system for recording and reproducing high-bandwidth signals. The RTS 2707 uses 12-bit, 500 MHz A/D converters and provides sustained recording rates up to 1.6 GB/sec in two-channel configuration.

The RTS 2707 uses Pentek's high-powered Virtex-6-based Cobalt modules, that provide flexibility in channel count, with optional digital downconversion capabilities. Optional 16-bit, 800 MHz D/A converters with digital upconversion allow real-time reproduction of recorded signals.

A/D sampling rate, DDC decimation and bandwidth, D/A sampling rate and DUC interpolation are among the GUI-selectable system parameters, providing a fully-programmable system capable of recording and reproducing a wide range of signals.

Optional GPS time and position stamping allows the user to record this critical signal information.

Included with the system is the SystemFlow Recording Software. SystemFlow features a Windows-based GUI that provides a simple means to configure and control the recorder. SystemFlow also includes signal viewing and analysis tools, that allow the user to monitor the signal prior to, during, and after a recording session. These tools include a virtual oscilloscope and a virtual spectrum analyzer.

Built on a Windows 7 Professional workstation, the RTS 2707 allows the user to install post-processing and analysis tools to operate on the recorded data. The RTS 2707 records data to the native NTFS file system, providing immediate access to the data.

The RTS 2707 is configured in a 4U 19" rackmountable chassis, with hot-swappable data drives, front panel USB ports and I/O connectors on the rear panel. Systems are scalable to increase channel counts and aggregate data rates.

Products

Ultra Wideband One- or Two-Channel RF/IF, 3.2 GS/sec Rackmount Recorder

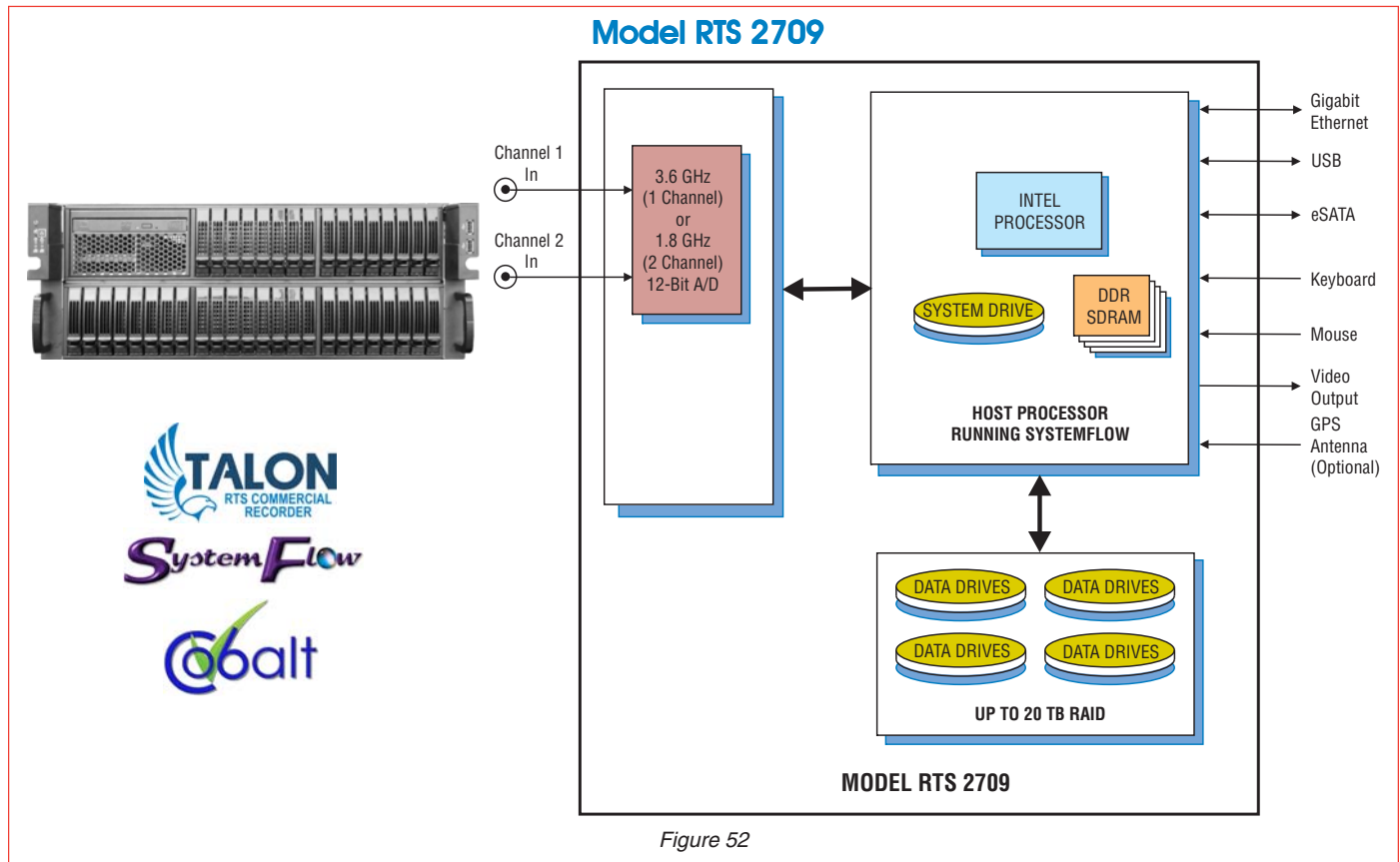

The Talon RTS 2709 is a turnkey system used for recording extremely high-bandwidth signals. The RTS 2709 uses a 12-bit, 3.6 GHz A/D converter and can provide sustained recording rates up to 3.2 GB/sec. It can be configured as a one- or two-channel system and can record sampled data, packed as 8-bit wide consecutive samples, or as 16-bit wide consecutive samples (12-bit digitized samples residing in the 12 MSBs of the 16-bit word.)

The RTS 2709 uses Pentek's high-powered Virtex-6-based Cobalt boards that provide the data streaming engine for the high-speed A/D converter. Channel and packing modes as well as gate and trigger settings are among the GUI-selectable system parameters, providing complete control over this ultra wideband recording system.

Optional GPS time and position stamping allows the user to capture this information in the header of each data file.

The RTS 2709 includes the SystemFlow Recording Software. SystemFlow features a Windows-based GUI that provides a simple means to configure and control the system. Custom configurations can be stored as profiles and later loaded when needed, allowing the user to select preconfigured settings with a single click.

SystemFlow also includes signal viewing and analysis tools that allow the user to monitor the signal prior to, during, and after a recording session.

Built on a Windows 7 Professional workstation, the RTS 2709 allows the user to install post-processing and analysis tools to operate on the recorded data. The RTS 2709 records data to the native NTFS file system that provides immediate access to the data. The RTS 2709 is configured in a 4U 19" rackmountable chassis, with hot-swap data drives, front panel USB ports and I/O connectors on the rear panel.

Products

Two-Channel 10-Gigabit Ethernet Rackmount Recorder

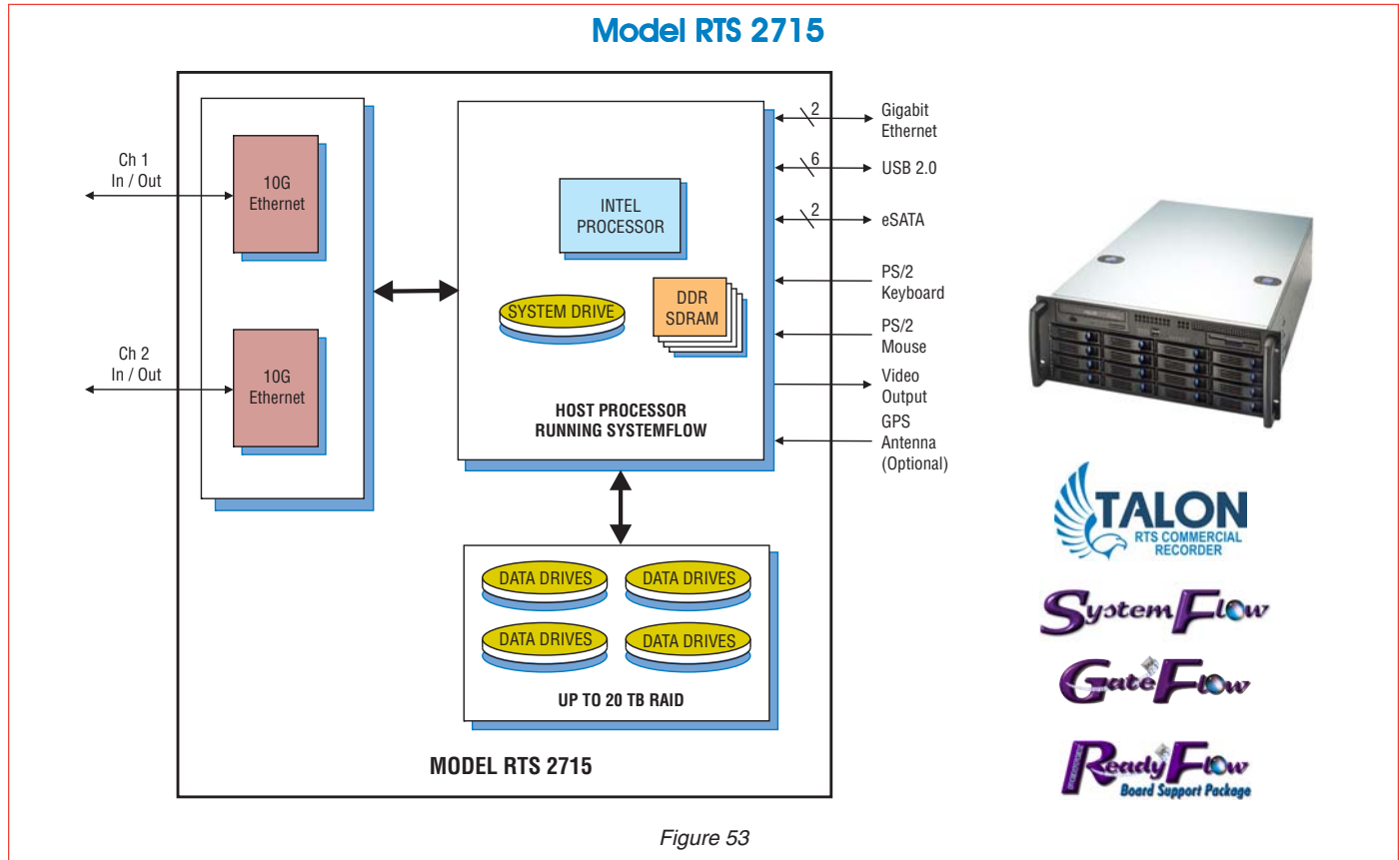

Figure 53

The Talon RTS 2715 is a complete turnkey recording system for storing one or two 10 gigabit Ethernet (10 GbE) streams. It is ideal for capturing any type of streaming sources including live transfers from sensors or data from other computers and supports both TCP and UDP protocols. Using highly-optimized disk storage technology, the system achieves aggregate recording rates up to 2.0 GB/sec.

Two rear panel SFP+LC connectors for 850 nm multi-mode or single-mode fibre cables, or CX4 connectors for copper twinax cables accommodate all popular 10 GbE interfaces. Optional GPS time and position stamping accurately identifies each record in the file header.

The RTS 2715 includes the SystemFlow Recording Software. SystemFlow features a Windows-based GUI (Graphical User Interface) that provides a simple and intuitive means to configure and control the system. Custom configurations can be stored as profiles and later

loaded as needed, allowing the user to select preconfigured settings with a single click.

Built on a server-class Windows 7 Professional workstation, the RTS 2715 allows the user to install post-processing and analysis tools to operate on the recorded data. The RTS 2715 records data to the native NTFS file system, providing immediate access to the data.

The RTS 2715 is configured in a 4U or 5U 19" rack-mountable chassis, with hot-swap data drives, front panel USB ports and I/O connectors on the rear panel. Systems are scalable to accommodate multiple chassis to increase channel counts and aggregate data rates.

All recorder chassis are connected via Ethernet and can be controlled from a single GUI either locally or from a remote PC.

Products

Eight-Channel Serial FPDP Rackmount Recorder

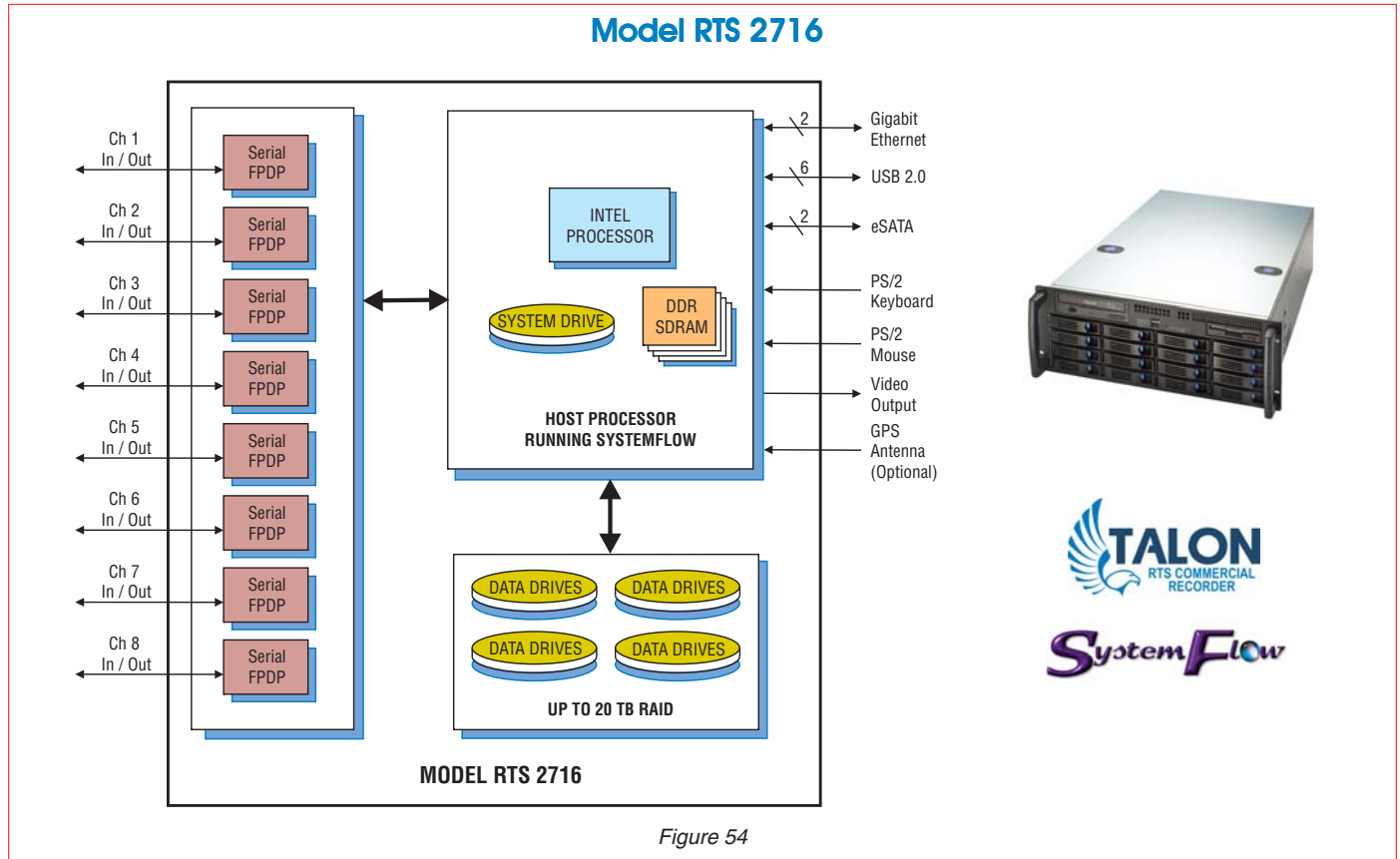

The Talon RTS 2716 is a complete turnkey recording system capable of recording and playing multiple serial FPDP data streams. It is ideal for capturing any type of streaming sources including live transfers from sensors or data from other computers and is fully compatible with the VITA 17.1 specification. Using highly-optimized disk storage technology, the system achieves aggregate recording rates up to 3.4 GB/sec.

The RTS 2716 can be populated with up to eight SFP connectors supporting serial FPDP over copper, single-mode, or multi-mode fiber, to accommodate all popular serial FPDP interfaces. It is capable of both receiving and transmitting data over these links and supports real-time data storage to disk.

Programmable modes include flow control in both receive and transmit directions, CRC support, and copy/loop modes. The system is capable of handling 1.0625,

2.125, 2.5, 3.125 and 4.25 GBaud link rates supporting data transfer rates of up to 425 MB/sec per serial FPDP link.

Built on a server-class Windows 7 Professional workstation, the RTS 2716 allows the user to install post-processing and analysis tools to operate on the recorded data. The RTS 2716 records data to the native NTFS file system, providing immediate access to the data.

The RTS 2716 is configured in a 4U or 5U 19" rack-mountable chassis, with hot-swap data drives, front panel USB ports and I/O connectors on the rear panel. Up to 24 hot-swappable SATA drives are optionally available, allowing up to 20 terabytes of real-time data storage space in a single chassis.

The RTS 2716 includes the SystemFlow Recording Software, which features a Windows-based GUI that provides a simple and intuitive means to configure and control the system.

Products

LVDS Digital I/O Rackmount Recorder

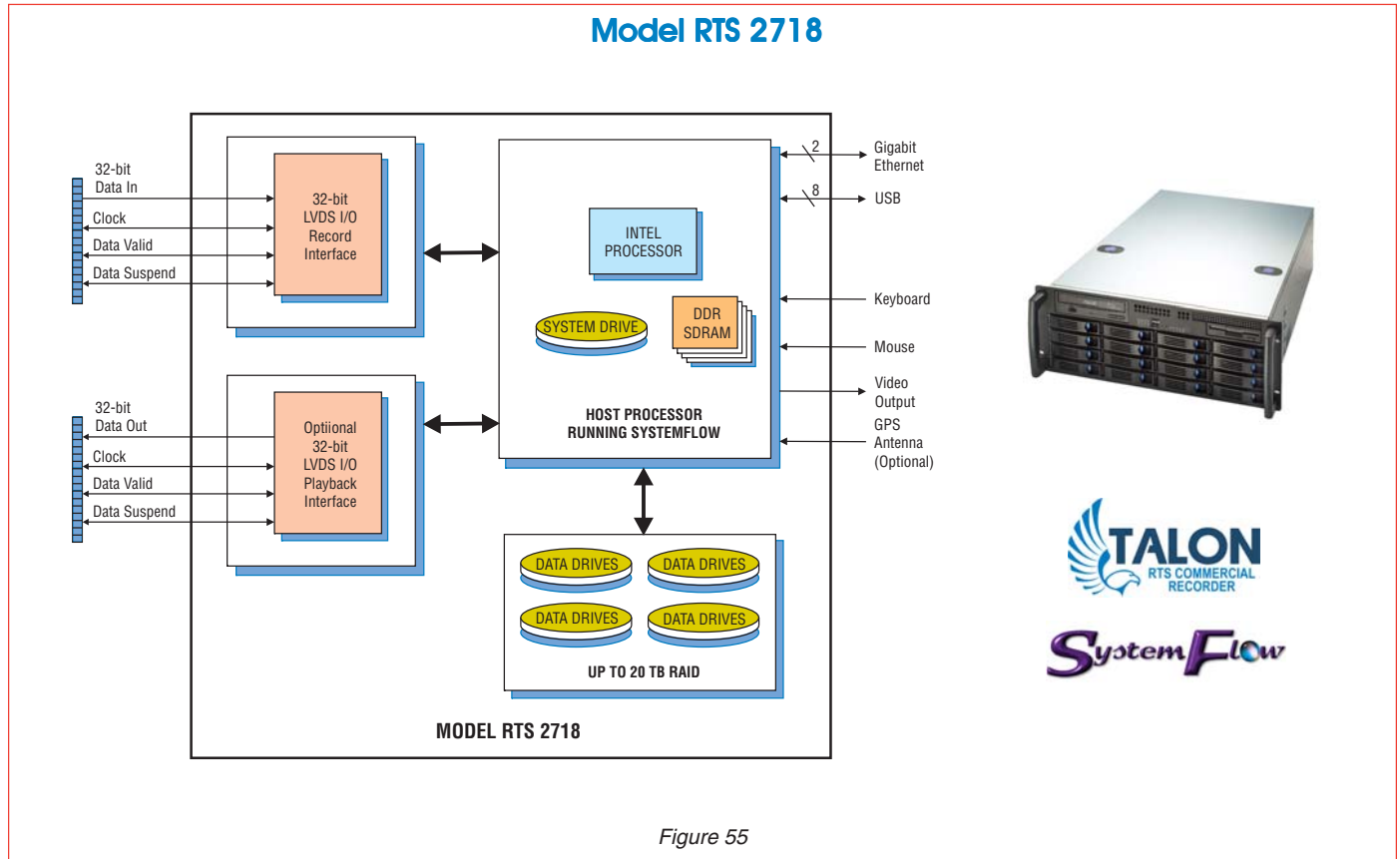

The Talon RTS 2718 is a complete turnkey system for recording and playing back digital data using a Pentek LVDS digital I/O board. Using highly optimized disk storage technology, the system achieves sustained recording rates of up to 1 GB/sec.

The RTS 2718 utilizes a 32-bit LVDS interface that can be clocked at speeds up to 250 MHz. It includes Data Valid and Suspend signals and provides the ability to turn these signals on and off as well as control their polarity.

The RTS 2718 includes the SystemFlow Recording Software. SystemFlow features a Windows-based GUI that provides a simple means to configure and control the system. Custom configurations can be stored as profiles and later loaded when needed, allowing the user to select preconfigured settings with a single click.

Built on a Windows 7 Professional workstation, the RTS 2718 allows the user to install post-processing and analysis tools to operate on the recorded data. The RTS 2718 records data to the native NTFS file system, providing immediate access to the recorded data.

Data can be off-loaded via two gigabit Ethernet ports or eight USB ports. Additionally, data can be copied to optical disk using the 8X double layer DVD \pm R/RW drive.

The RTS 2718 is configured in a 4U 19" rack-mountable chassis, with hot-swap data drives, front panel USB ports and I/O connectors on the rear panel. Systems are scalable to accommodate multiple chassis to increase channel counts and aggregate data rates. All recorder chassis are connected via Ethernet and can be controlled from a single GUI either locally or from a remote PC.

Products

Four-Channel RF/IF 200 MS/sec Rugged Portable Recorder

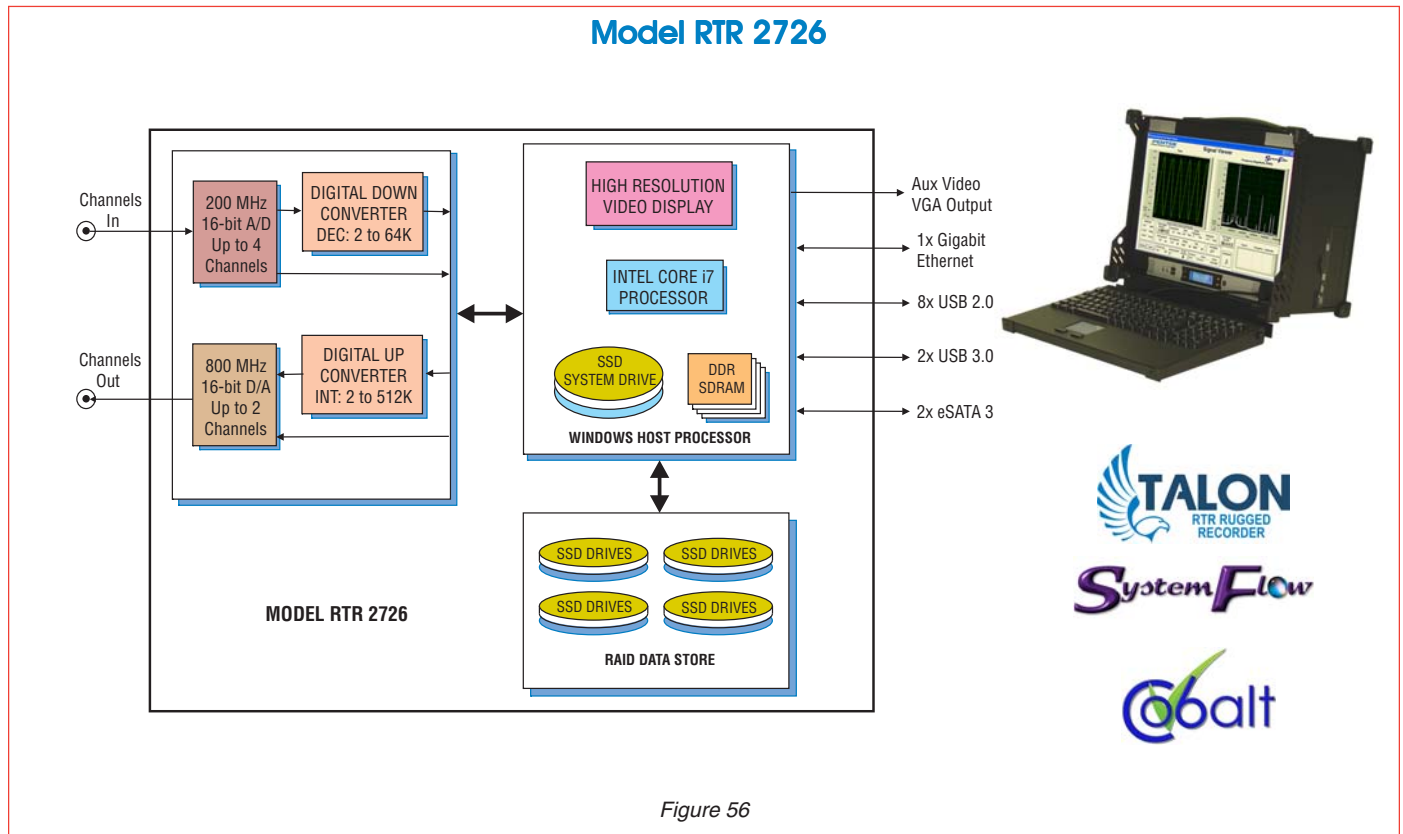

Figure 56

The Talon RTR 2726 is a turnkey, multiband recording and playback system designed to operate under conditions of shock and vibration. It allows the user to record and reproduce high-bandwidth signals with a lightweight, portable and rugged package. The RTR 2726 provides sustained recording rates of up to 1.6 GB/sec in a four-channel system and is ideal for the user who requires both portability and solid performance in a compact recording system.

The RTR 2726 is supplied in a small footprint portable package measuring just 16.9" W x 9.5" D x 13.4" H and weighing about 30 pounds. With measurements similar to a small briefcase, this portable workstation includes an Intel Core i7 processor, a high-resolution 17" LCD monitor, and a high-performance SATA RAID controller.

At the heart of the RTR 2726 are Pentek Cobalt Series Virtex-6 software radio boards featuring A/D and

D/A converters, DDCs (Digital Downconverters), DUCs (Digital Upconverters), and complementary FPGA IP cores. This architecture allows the system engineer to take full advantage of the latest technology in a turnkey system. Optional GPS time and position stamping allows the user to record this critical signal information.

It is built on an extremely rugged, 100% aluminum alloy unit, reinforced with shock absorbing rubber corners and an impact-resistant protective glass. Using vibration and shock resistant SSDs, the RTR 2726 is designed to reliably operate as a portable field instrument in harsh environments.

The eight hot-swappable SSDs provide a storage capacity of up to 3.8 TB. The drives can be easily removed or exchanged during or after a mission to retrieve recorded data. Because SSDs operate reliably under conditions of vibration and shock, the RTR 2726 performs well in ground, shipborne and airborne environments.

Products

Two-Channel RF/IF 500 MS/sec Rugged Portable Recorder

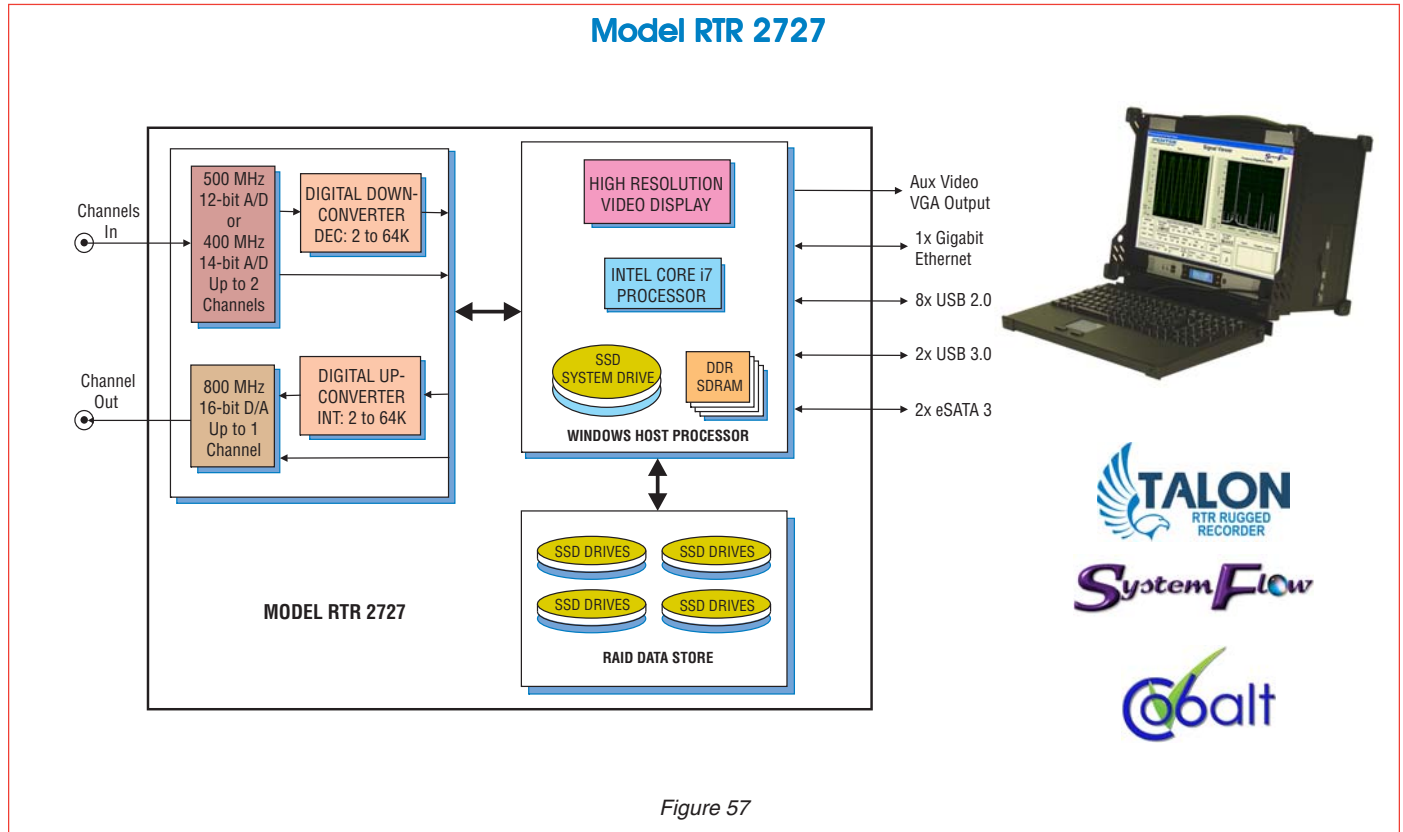

The Talon RTR 2727 is a turnkey, multiband recording and playback system designed to operate under conditions of shock and vibration. It allows the user to record and reproduce high-bandwidth signals with a lightweight, portable and rugged package. The RTR 2727 provides sustained recording rates of up to 2.0 GB/sec in a two-channel system and is ideal for the user who requires both portability and solid performance in a compact recording system.

The RTR 2727 is supplied in a small footprint portable package measuring just 16.9" W x 9.5" D x 13.4" H and weighing about 30 pounds. With measurements similar to a small briefcase, this portable workstation includes an Intel Core i7 processor, a high-resolution 17" LCD monitor, and a high-performance SATA RAID controller.

At the heart of the RTR 2727 are Pentek Cobalt Series Virtex-6 software radio boards featuring A/D and

D/A converters, DDCs (Digital Downconverters), DUCs (Digital Upconverters), and complementary FPGA IP cores. This architecture allows the system engineer to take full advantage of the latest technology in a turnkey system. Optional GPS time and position stamping allows the user to record this critical signal information.

It is built on an extremely rugged, 100% aluminum alloy unit, reinforced with shock absorbing rubber corners and an impact-resistant protective glass. Using vibration and shock resistant SSDs, the RTR 2727 is designed to reliably operate as a portable field instrument in harsh environments.

The eight hot-swappable SSDs provide a storage capacity of up to 3.8 TB. The drives can be easily removed or exchanged during or after a mission to retrieve recorded data. Because SSDs operate reliably under conditions of vibration and shock, the RTR 2727 performs well in ground, shipborne and airborne environments.

Products

Eight-Channel Serial FPDP Rugged Portable Recorder

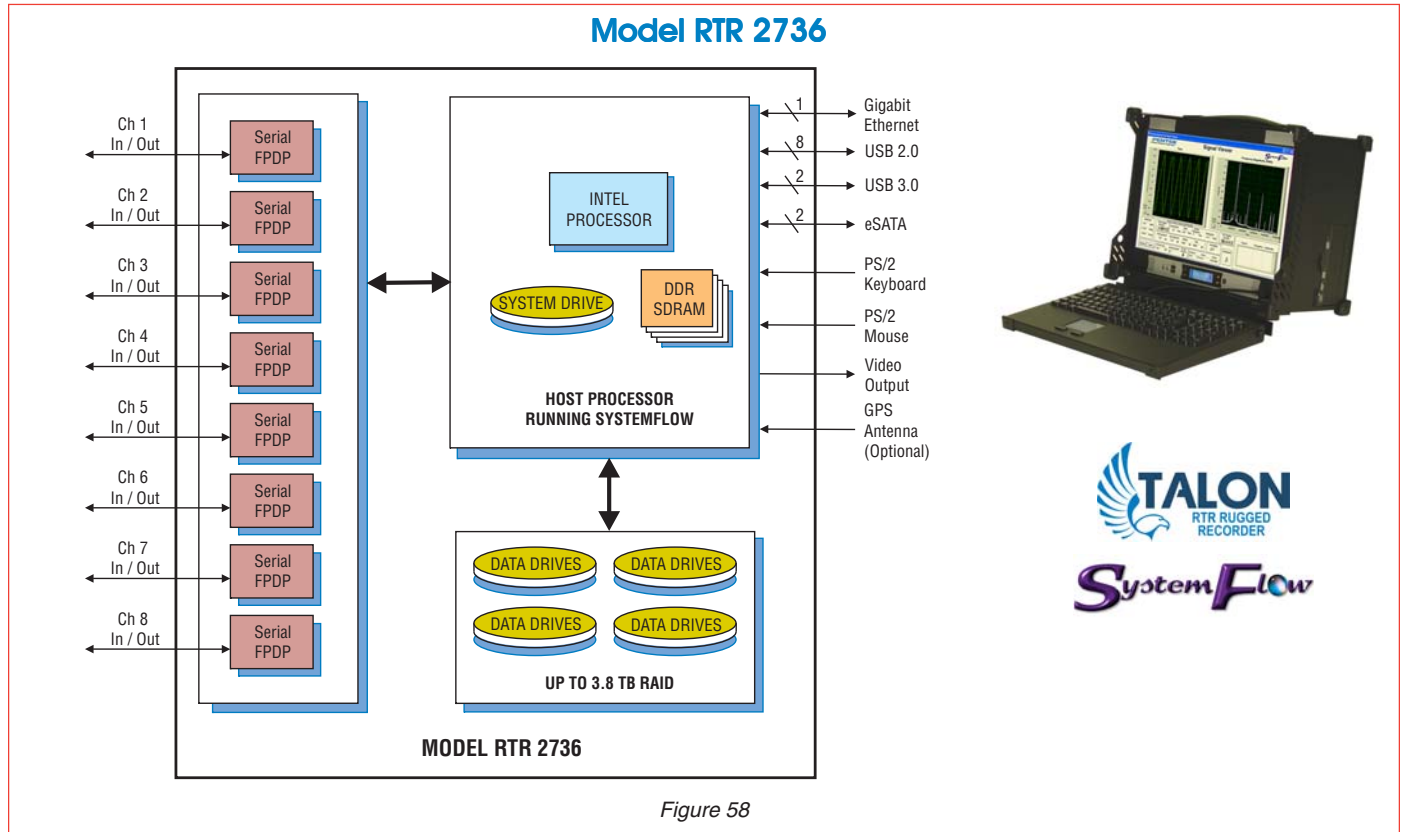

Figure 58

The Talon RTR 2736 is a complete turnkey recording system designed to operate under conditions of shock and vibration. It records and plays back multiple serial FPDP data streams in a rugged, lightweight portable package. It is ideal for capturing any type of streaming sources including live transfers from sensors or data from other computers and is fully compatible with the VITA 17.1 specification. Using highly-optimized disk storage technology, the system achieves aggregate recording rates up to 1.6 GB/sec.

The RTR 2736 can be populated with up to eight SFP connectors supporting serial FPDP over copper, single-mode, or multi-mode fiber, to accommodate all popular serial FPDP interfaces. It is capable of both receiving and transmitting data over these links and supports real-time data storage to disk. The system is capable of handling 1.0625, 2.125, 2.5, 3.125 and 4.25 GBaud link rates supporting data transfer rates of up to 200 MB/sec per serial FPDP link.

The RTR 2736 includes the SystemFlow Recording Software. SystemFlow features a Windows-based GUI that provides a simple and intuitive means to configure and control the system. Custom configurations can be stored as profiles and later loaded as needed, allowing the user to select preconfigured settings with a single click.

The RTR 2736 is configured in a portable, lightweight chassis with eight hot-swap SSDs, front panel USB ports and I/O connections on the side panel. It is built on an extremely rugged, 100% aluminum alloy unit, reinforced with shock absorbing rubber corners and an impact-resistant protective glass. Using vibration and shock resistant SSDs, the RTR 2736 is designed to reliably operate as a portable field instrument in harsh environments.

The eight hot-swappable SSDs provide storage capacities of up to 3.8 TB. Drives can be easily removed or exchanged during or after a mission to retrieve recorded data.

Products

LVDS Digital I/O Rugged Portable Recorder

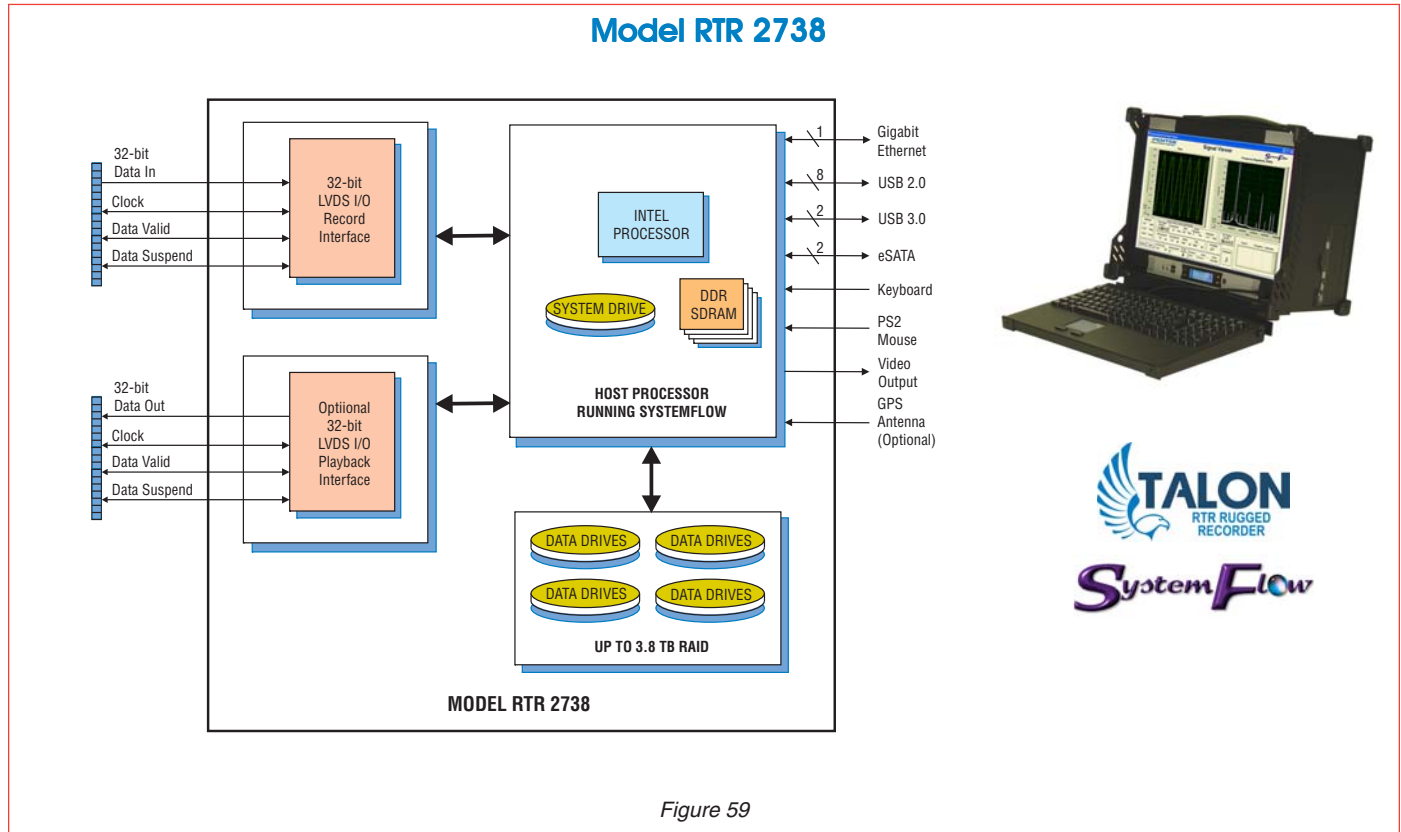

Figure 59

The Talon RTR 2738 is a complete turnkey system for recording and playing back digital data using a Pentek LVDS digital I/O board. Using highly optimized disk storage technology, the rugged, lightweight portable package achieves sustained recording rates of up to 1 GB/sec.

The RTR 2738 utilizes a 32-bit LVDS interface that can be clocked at speeds up to 250 MHz. It includes Data Valid and Suspend signals and provides the ability to turn these signals on and off as well as control their polarity. Optional GPS time and position stamping accurately identifies each record in the file header.

The RTR 2738 includes the SystemFlow Recording Software. SystemFlow features a Windows-based GUI that provides a simple means to configure and control the system. Custom configurations can be stored as profiles and later loaded when needed, allowing the user to select preconfigured settings with a single click.

Built on a Windows 7 Professional workstation, the RTR 2738 allows the user to install post-processing and analysis tools to operate on the recorded data. The RTR 2738 records data to the native NTFS file system, providing immediate access to the recorded data.

Data can be off-loaded via a gigabit Ethernet port, eight USB 2.0 ports, two USB 3.0 ports or two eSATA 3 Ports. Additionally, data can be copied to optical disk, using the 8X double layer DVD \pm R/RW drive.

The RTR 2738 is configured in a portable, lightweight chassis with eight hot-swap SSDs, front panel USB ports and I/O connections on the side panel. It is built on an extremely rugged, 100% aluminum alloy unit, reinforced with shock absorbing rubber corners and an impact-resistant protective glass. Using shock- and vibration-resistant SSDs, the RTR 2738 is designed to reliably operate as a portable field instrument.

Products

Eight-Channel RF/IF 200 MS/Sec Rugged Rackmount Recorder

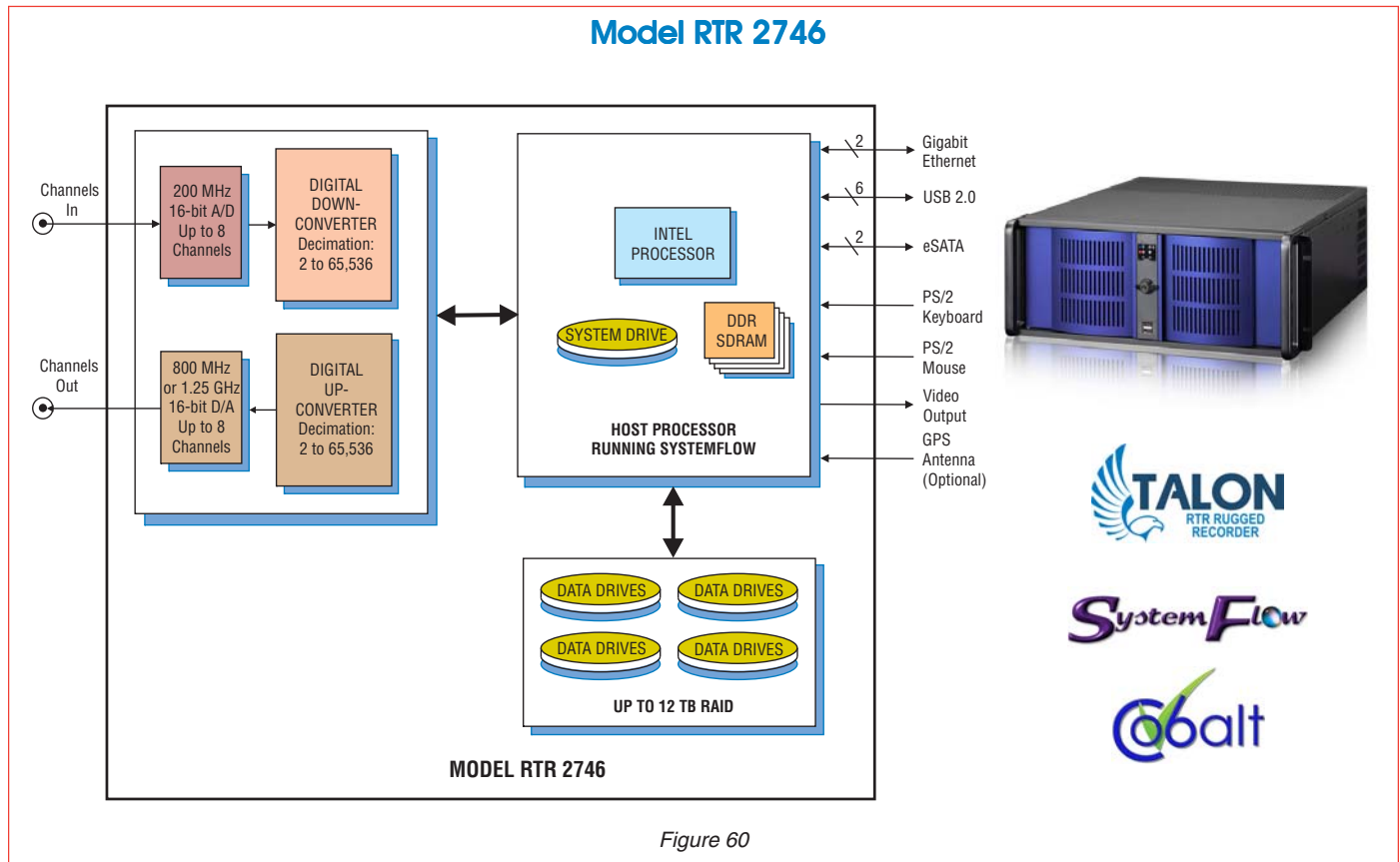

The Talon RTR 2746 is a turnkey multiband recording and playback system designed to operate under conditions of shock and vibration. The RTR 2746 is intended for military, airborne, and UAV applications requiring a rugged system. With scalable A/Ds, D/As and SSD (solid-state drive) storage, the RTR 2746 can be configured to stream data to and from disk at rates as high as 2.0 GB/sec.

The RTR 2746 uses Pentek's high-performance Virtex-6-based Cobalt boards, that provide flexibility in channel count with optional digital downconversion capabilities. Optional 16-bit, 800 MHz or 1.25 GHz D/A converters with digital upconversion allow real-time reproduction of recorded signals.

A/D sampling rate, DDC decimation and bandwidth, D/A sampling rate, and DUC interpolation are among the GUI-selectable system parameters, that provide a fully programmable system.

The 24 hot-swappable SSD's provide storage capacity of up to 12 TB. The drives can be easily removed or exchanged during or after a mission to retrieve recorded data. Because SSDs operate reliably under conditions of vibration and shock, the RTR 2746 performs well in ground, shipborne and airborne environments.

The RTR 2746 is configured in a 4U 19" rugged rackmountable chassis, with hot-swap data drives, front panel USB ports and I/O connectors on the rear panel.

All recorder chassis are connected via Ethernet and can be controlled from a single GUI either locally or from a remote PC. Multiple RAID levels, including 0, 1, 5, 6, 10, and 50, provide a choice for the required level of redundancy.

Systems are scalable to accommodate multiple chassis to increase channel counts and aggregate data rates.

Products

Four-Channel RF/IF 500 MS/Sec Rugged Rackmount Recorder

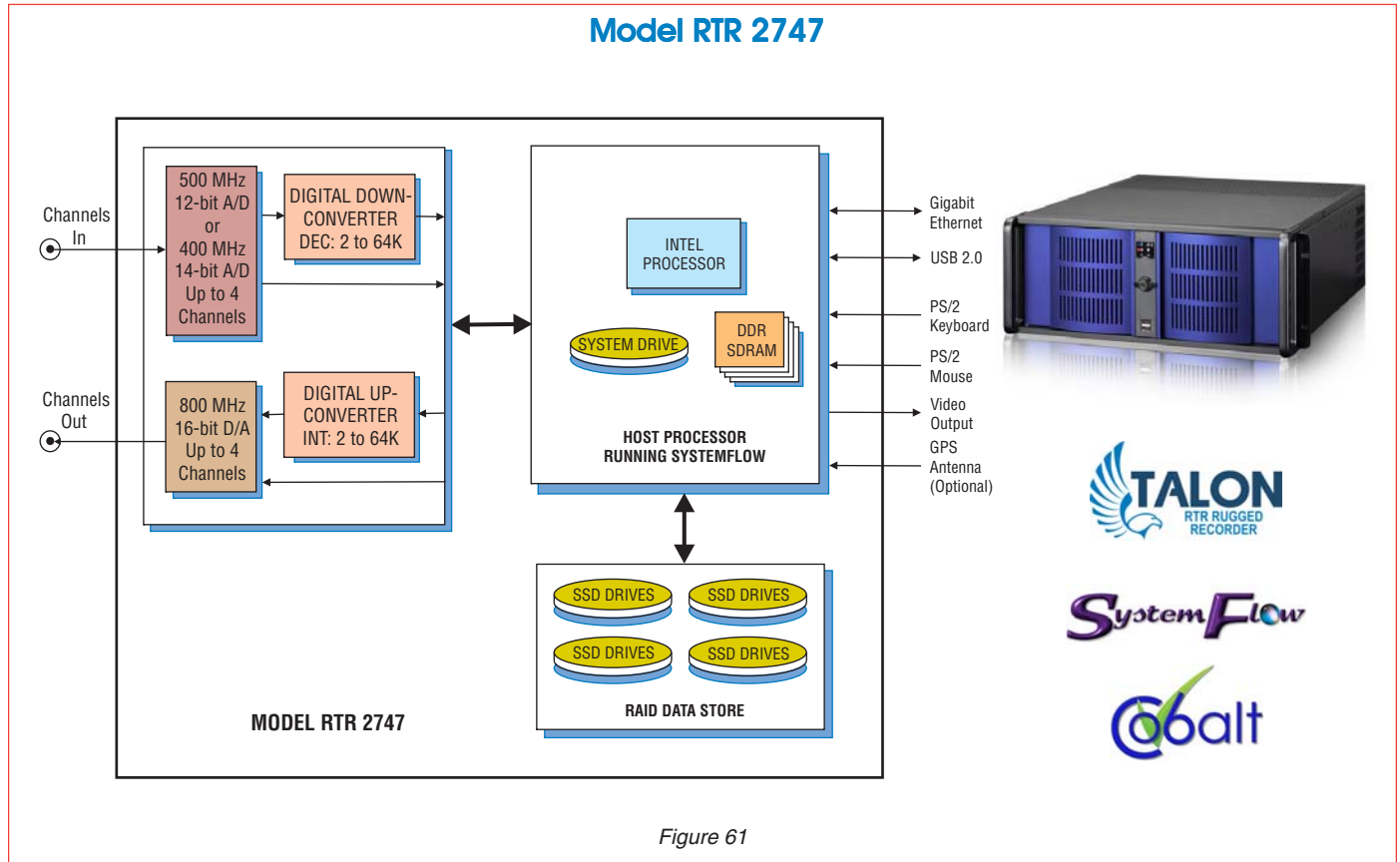

Figure 61

The Talon RTR 2747 is a turnkey multiband recording and playback system designed to operate under conditions of shock and vibration. The RTR 2747 is intended for military, airborne, and UAV applications requiring a rugged system. With scalable A/Ds, D/As and SSD (solid-state drive) storage, the RTR 2747 can be configured to stream data to and from disk at rates as high as 4.0 GB/sec.

The RTR 2747 uses Pentek's high-performance Virtex-6-based Cobalt boards, that provide flexibility in channel count with optional digital downconversion capabilities. Optional 16-bit, 800 MHz converters with digital upconversion allow real-time reproduction of recorded signals.

A/D sampling rate, DDC decimation and bandwidth, D/A sampling rate, and DUC interpolation are among the GUI-selectable system parameters, that provide a fully programmable system.

The hot-swappable SSD's provide storage capacity of up to 11.5 TB. The drives can be easily removed or exchanged during or after a mission to retrieve recorded data. Because SSDs operate reliably under conditions of vibration and shock, the RTR 2747 performs well in ground, shipborne and airborne environments.

The RTR 2747 is configured in a 4U 19" rugged rackmountable chassis, with hot-swap data drives, front panel USB ports and I/O connectors on the rear panel.

All recorder chassis are connected via Ethernet and can be controlled from a single GUI either locally or from a remote PC. Multiple RAID levels, including 0, 1, 5, 6, 10, and 50, provide a choice for the required level of redundancy.

Systems are scalable to accommodate multiple chassis to increase channel counts and aggregate data rates.

Products

Ultra Wideband One- or Two-Channel RF/IF, 3.2 GS/sec Rugged Rackmount Recorder

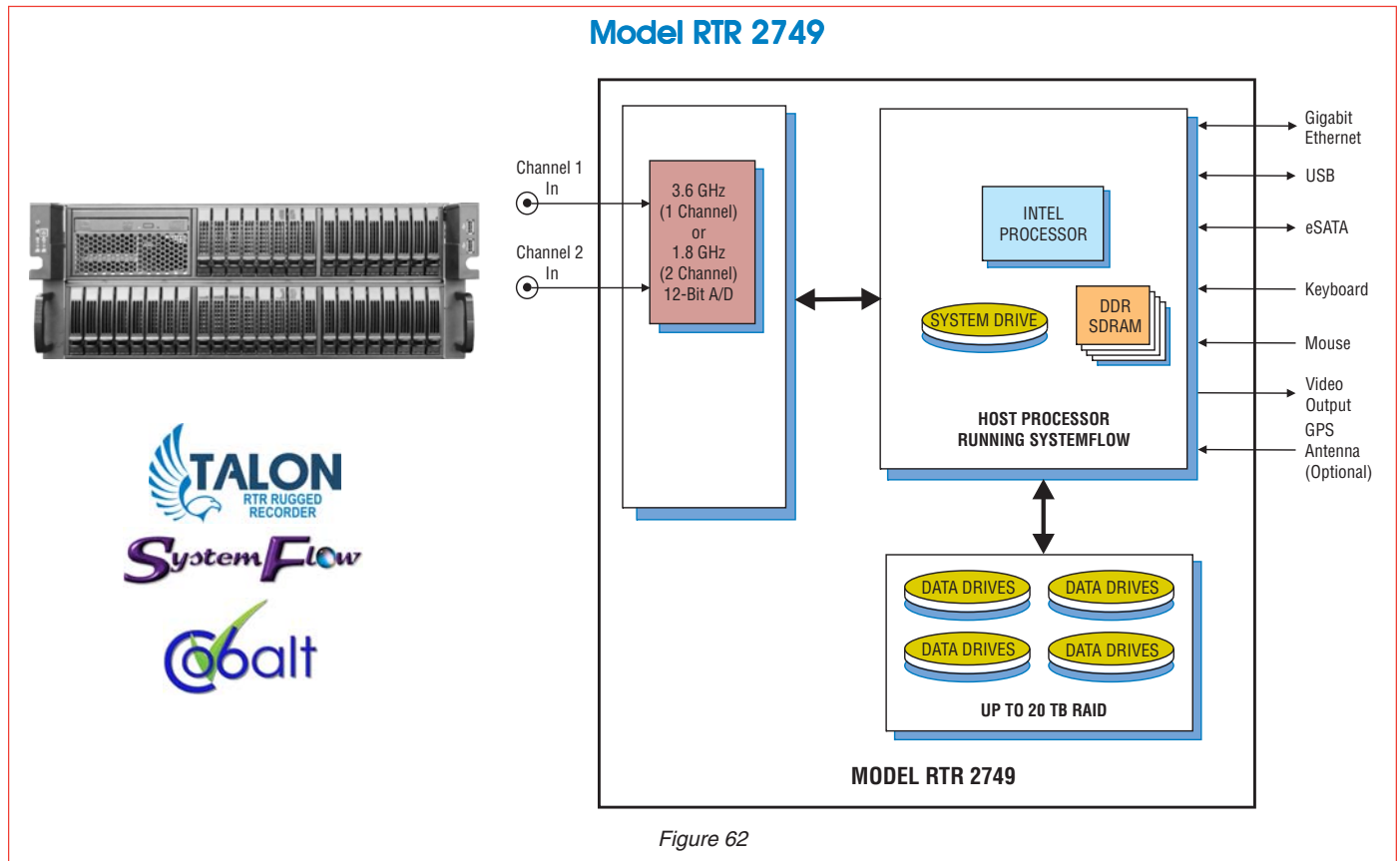

Designed to operate under conditions of shock and vibration, the Talon RTR 2749 is a turnkey system used for recording extremely high-bandwidth signals. The RTR 2749 uses a 12-bit, 3.6 GHz A/D converter and can provide sustained recording rates up to 3.2 GB/sec. It can be configured as a one- or two-channel system and can record sampled data, packed as 8-bit wide consecutive samples, or as 16-bit wide consecutive samples (12-bit digitized samples residing in the 12 MSBs of the 16-bit word.)

The RTR 2749 uses Pentek's high-performance Virtex-6-based Cobalt boards that provide the data streaming engine for the high-speed A/D converter. Channel and packing modes as well as gate and trigger settings are among the GUI-selectable system parameters, providing complete control over this ultra-wideband recording system. Optional GPS time and position stamping allows the user to capture this information in the header of each data file.

The RTR 2749 includes the SystemFlow Recording Software. SystemFlow features a Windows-based GUI that provides a simple means to configure and control the system. Custom configurations can be stored as profiles and later loaded when needed, allowing the user to select preconfigured settings with a single click. SystemFlow also includes signal viewing and analysis tools that allow the user to monitor the signal prior to, during, and after a recording session.

Built on a Windows 7 Professional workstation, the RTR 2749 allows the user to install post-processing and analysis tools to operate on the recorded data. The hot-swappable SSDs provide a storage capacity of up to 19.2 TB. The drives can be easily removed or exchanged during or after a mission to retrieve recorded data. Because SSDs operate reliably under conditions of vibration and shock, the RTR 2749 performs well in ground, shipborne and airborne environments.

Products

Two-Channel 10-Gigabit Ethernet Rugged Rackmount Recorder

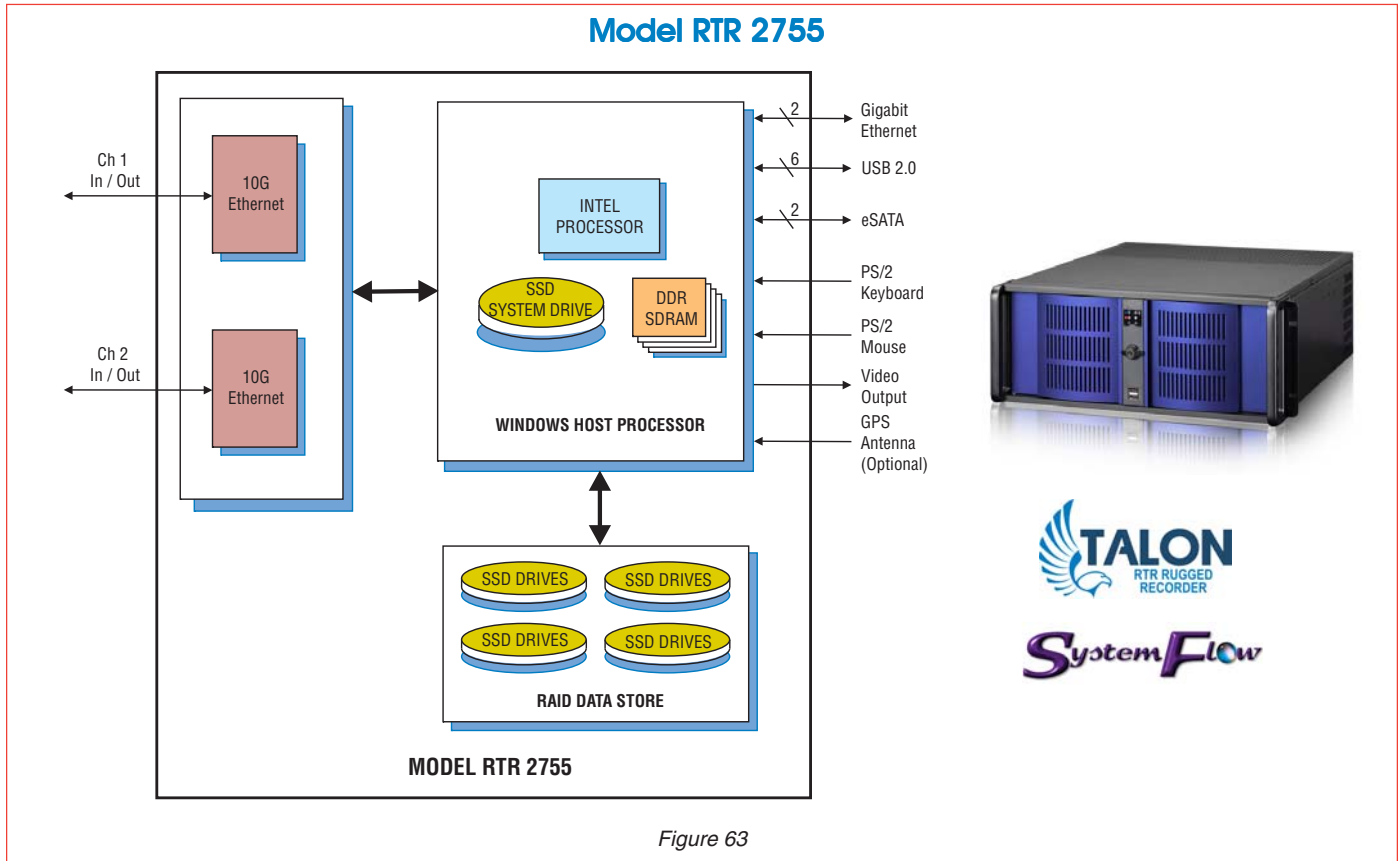

Designed to operate under conditions of shock and vibration, the Talon RTR 2755 is a complete turnkey recording system for storing one or two 10 gigabit Ethernet (10 GbE) streams. It is ideal for capturing any type of streaming sources including live transfers from sensors or data from other computers and supports both TCP and UDP protocols.

Using highly-optimized solid-state drive storage technology, the system guarantees loss-free performance at aggregate recording rates up to 2.0 GB/sec.

Two rear panel SFP+ LC connectors for 850 nm multi-mode or single-mode fibre cables, or CX4 connectors for copper twinax cables accommodate all popular 10 GbE interfaces.

Optional GPS time and position stamping accurately identifies each record in the file header.

The RTR 2755 includes the SystemFlow Recording Software that provides a simple and intuitive means to configure and control the system. Custom configurations can be stored as profiles and later loaded as needed, allowing the user to select preconfigured settings with a single click.

Built on a server-class Windows 7 Professional workstation, the RTR 2755 allows the user to install post-processing and analysis tools to operate on the recorded data. The RTR 2755 records data to the native NTFS file system, providing immediate access to the recorded data.

Because SSDs operate reliably under conditions of vibration and shock, the RTR 2755 performs well in ground, shipborne and airborne environments. The 24 hot-swappable SSD's provide a storage capacity of up to 12 TB. The drives can be easily removed or exchanged during or after a mission to retrieve recorded data.

Products

Eight-Channel Serial FPDP Rugged Rackmount Recorder

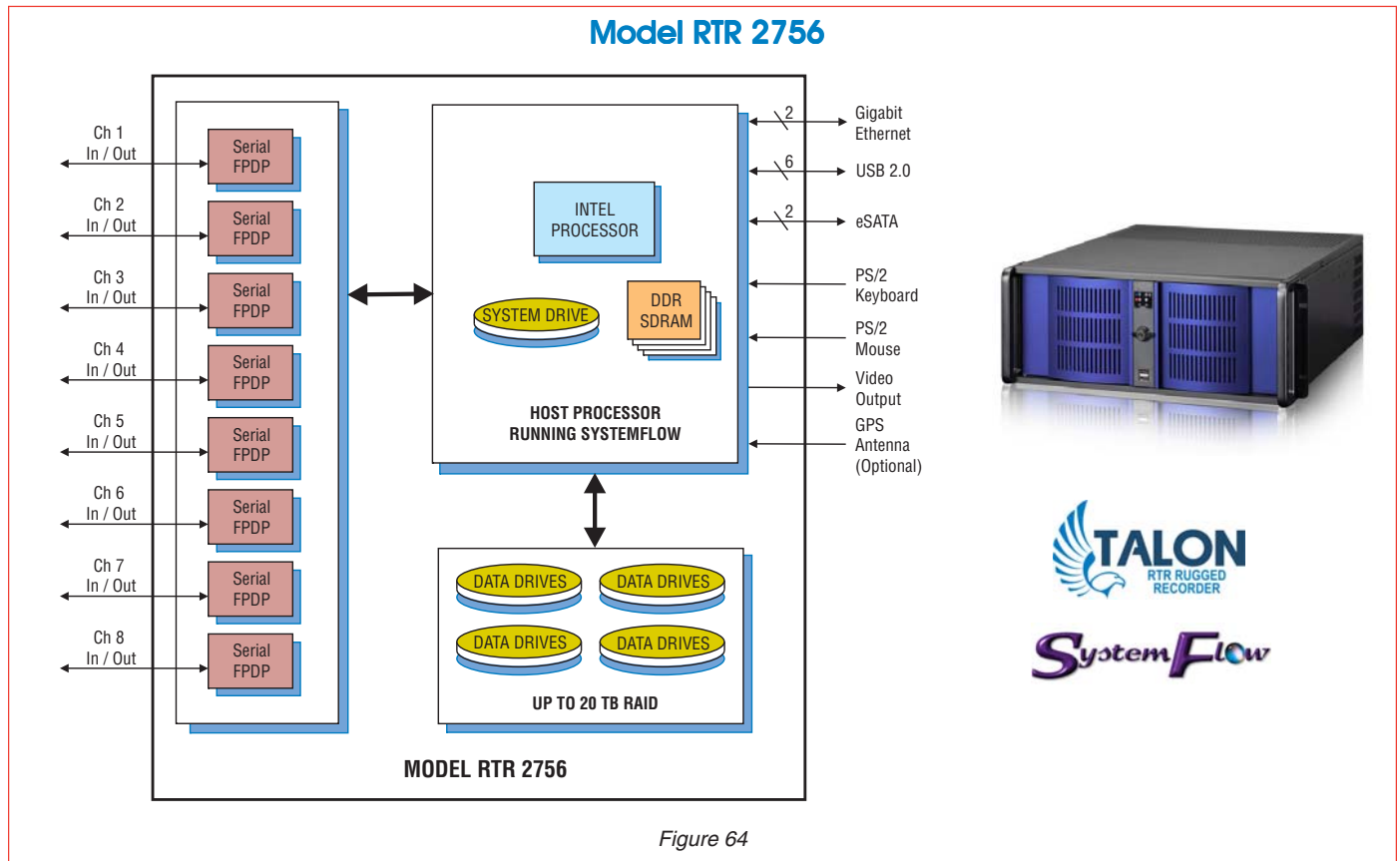

Designed to operate under conditions of shock and vibration, the Talon RTR 2756 is a complete turnkey recording system capable of recording and playing multiple serial FPDP data streams. It is ideal for capturing any type of streaming sources and is fully compatible with the VITA 17.1 specification. Using highly-optimized disk storage technology, the system achieves aggregate recording rates up to 3.4 GB/sec.

The RTR 2756 can be populated with up to eight SFP connectors supporting serial FPDP over copper, single-mode, or multi-mode fiber to accommodate all popular serial FPDP interfaces. It is capable of both receiving and transmitting data over these links and supports real-time data storage to disk. The system is capable of handling 1.0625, 2.125, 2.5, 3.125 and 4.25 GBaud link rates supporting data transfer rates of up to 425 MB/sec per serial FPDP link.

Built on a server-class Windows 7 Professional workstation, the RTR 2756 allows the user to install post-processing and analysis tools to operate on the recorded data. The RTR 2756 records data to the native NTFS file system, providing immediate access to the data.

Because SSDs operate reliably under conditions of vibration and shock, the RTR 2756 performs well in ground, ship and airborne environments. Configurable with as many as 40 hot-swappable SSDs, the RTR 2756 can provide storage capacities of up to 19.2 TB in a rugged 4U chassis. Drives can be easily removed or exchanged during or after a mission to retrieve recorded data.

Multiple RAID levels, including 0,1,5, 6, 10 and 50 provide a choice for the required level on redundancy. Redundant power supplies are optionally available to provide a robust and reliable high-performance recording system.

Products

LVDS Digital I/O Rugged Rackmount Recorder

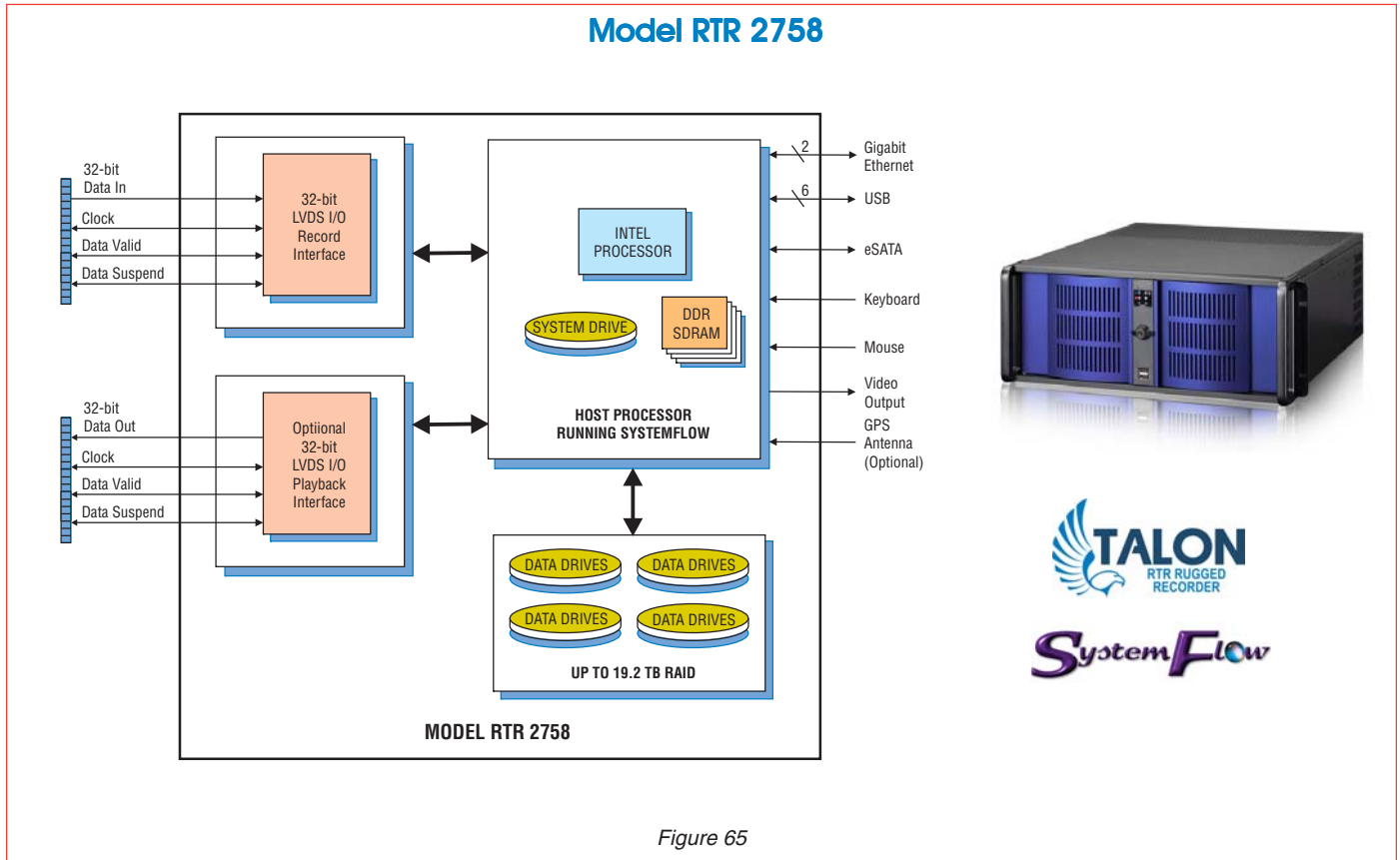

Figure 65

The Talon RTR 2758 is a complete turnkey system for recording and playing back digital data using a Pentek LVDS digital I/O board. Using highly optimized disk storage technology, the rugged rackmount system achieves sustained recording rates up to 1 GB/sec.

The RTR 2758 utilizes a 32-bit LVDS interface that can be clocked at speeds up to 250 MHz. It includes Data Valid and Suspend signals and provides the ability to turn these signals on and off as well as control their polarity. Optional GPS time and position stamping accurately identifies each record in the file header.

The RTR 2758 includes the SystemFlow Recording Software. SystemFlow features a Windows-based GUI that provides a simple means to configure and control the system. Custom configurations can be stored as profiles and later loaded when needed, allowing the user to select preconfigured settings with a single click.

Built on a Windows 7 Professional workstation, the RTR 2758 allows the user to install post-processing and analysis tools to operate on the recorded data. The RTR 2758 records data to the native NTFS file system, providing immediate access to the recorded data.

Because SSDs operate reliably under conditions of shock and vibration, the RTR 2758 performs well in ground, shipborne and airborne environments. Configurable with as many as 40 hot-swappable SSDs, the RTR 2758 can provide storage capacities of up to 19.2 TB in a rugged 4U chassis. Drives can be easily removed or exchanged during or after a mission to retrieve recorded data.

The RTR 2758 is configured in a 4U 19" rack-mountable chassis, with hot-swap data drives, front panel USB ports and I/O connectors on the rear panel. Systems are scalable to accommodate multiple chassis that increase channel counts and aggregate data rates.

Products

Four-Channel RF/IF 200 MS/Sec Extreme 3U VPX Recorder

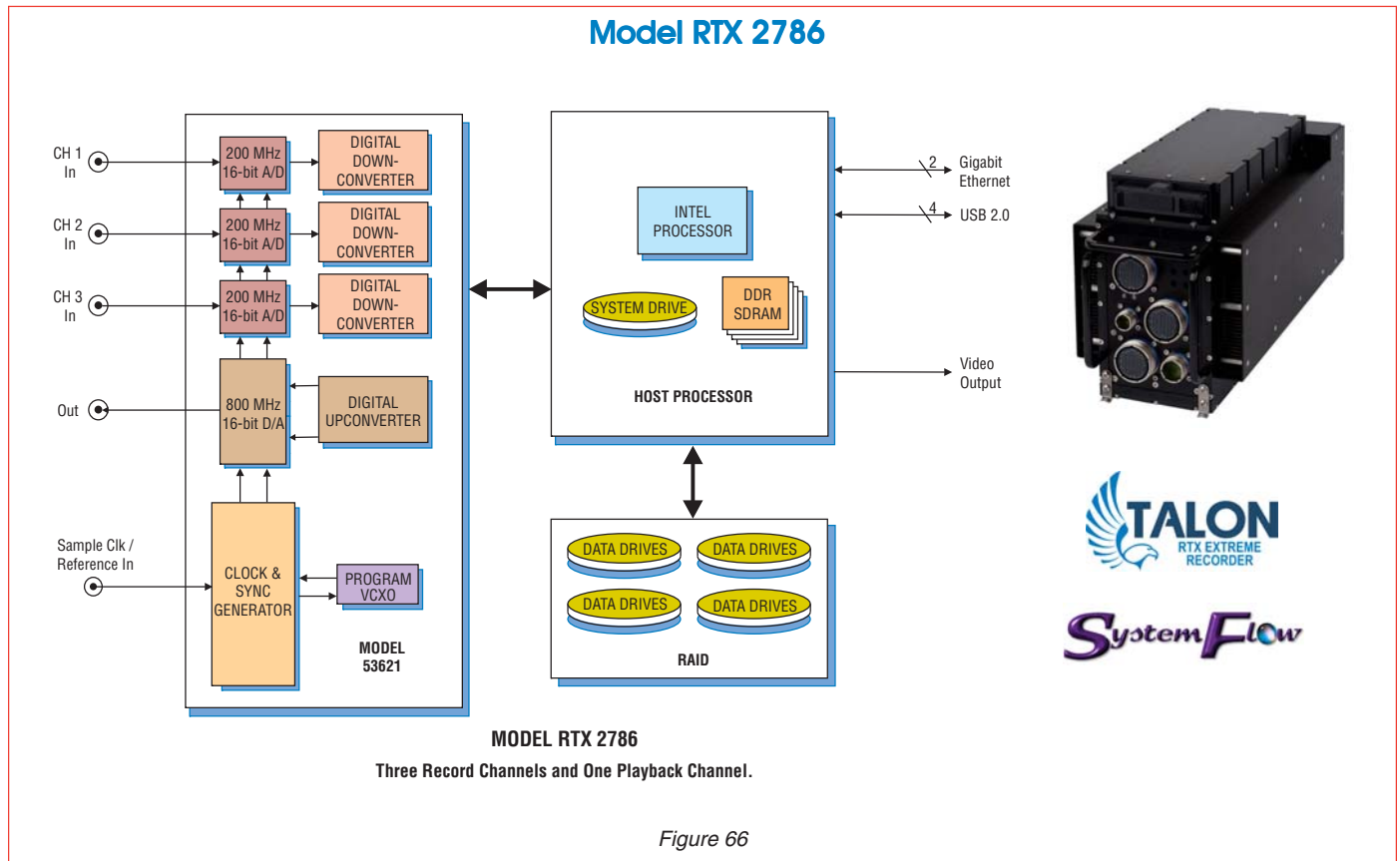

The Talon RTX 2786 is a turnkey, RF/IF signal recorder designed to operate under extreme environmental conditions. Housed in a 1/2 ATR chassis, the RTX 2786 leverages Pentek's 3U VPX SDR modules to provide a rugged recording system with up to four 16-bit, 200 MHz A/D converters with built-in digital downconversion capabilities. Optionally, the RTX 2786 provides one 800 MHz, 16-bit D/A converter with a digital upconverter for signal playback or waveform generation. As shown in the block diagram, the maximum number of record channels with this option is three.

The RTX 2786 uses conduction cooling to draw heat from the system components allowing it to operate in reduced air environments. It includes 1.92 TB of solid-state data storage, that allows it to operate with no degradation under conditions of extreme shock and vibration. The system is hermetically sealed and provides five D38999 connectors for power and I/O with four SMA connectors for analog I/O.

The RTX 2786 includes Pentek's SystemFlow Recording Software. SystemFlow features a Windows-based GUI that provides a simple means to configure and control the system. Custom configurations can be stored as profiles and later loaded when needed, allowing the user to select preconfigured settings with a single click. SystemFlow also includes signal viewing and analysis tools, that allow the user to monitor the signal prior to, during, and after a recording session. These tools include a virtual oscilloscope and a virtual spectrum analyzer.

The user API allows users to integrate the recorder as a subsystem of a larger system. The API is provided as a C-callable library and allows for the recorder to be controlled over Ethernet, thus providing the ability to remotely control the recorder from a custom interface.

Four built-in solid-state drives provide reliable, high-speed storage with a total capacity of 1.92 TB.

Products

Pentek SystemFlow Recording Software for Analog Recorders

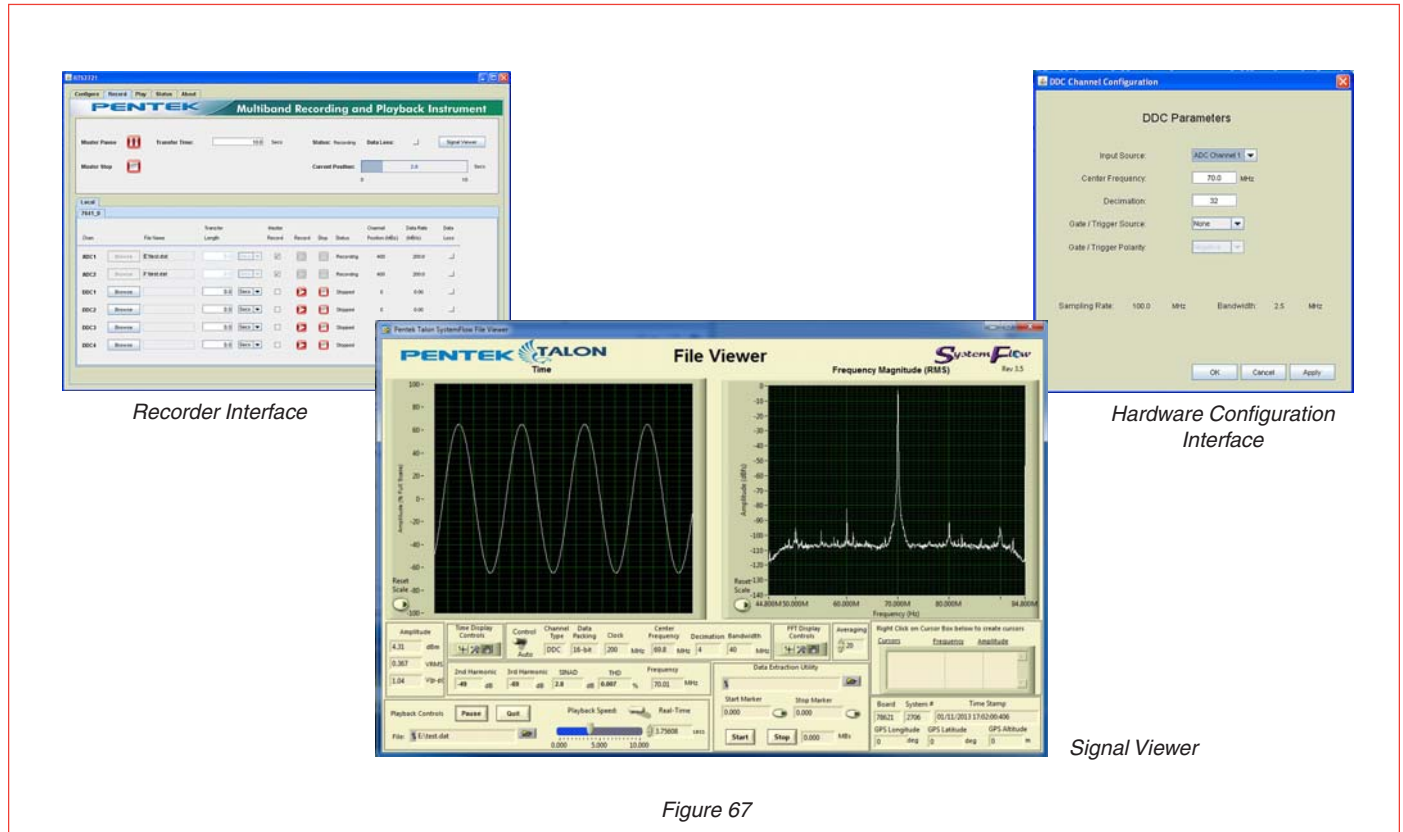

Figure 67

The Pentek SystemFlow Recording Software for Analog Recorders provides a rich set of function libraries and tools for controlling all Pentek high-speed real-time recording systems. SystemFlow software allows developers to configure and customize system interfaces and behavior.

The **Recorder Interface** includes configuration, record, playback and status screens, each with intuitive controls and indicators. The user can easily move between screens to set configuration parameters, control and monitor a recording, play back a recorded signal and monitor board temperatures and voltage levels.

The **Hardware Configuration Interface** provides entries for input source, center frequency, decimation, as well as gate and trigger information. All parameters contain limit-checking and integrated help to provide an easier-to-use out-of-the-box experience.

The SystemFlow **Signal Viewer** includes a virtual oscilloscope and spectrum analyzer for signal monitoring in both the time and frequency domains. It is extremely useful for previewing live inputs prior to recording, and for monitoring signals as they are being recorded to help ensure successful recording sessions. The viewer can also be used to inspect and analyze the recorded files after the recording is complete.

Advanced signal analysis capabilities include automatic calculators for signal amplitude and frequency, second and third harmonic components, THD (total harmonic distortion) and SINAD (signal to noise and distortion). With time and frequency zoom, panning modes and dual annotated cursors to mark and measure points of interest, the SystemFlow Signal Viewer can often eliminate the need for a separate oscilloscope or spectrum analyzer in the field.

Products

Pentek SystemFlow Recording Software for Digital Recorders

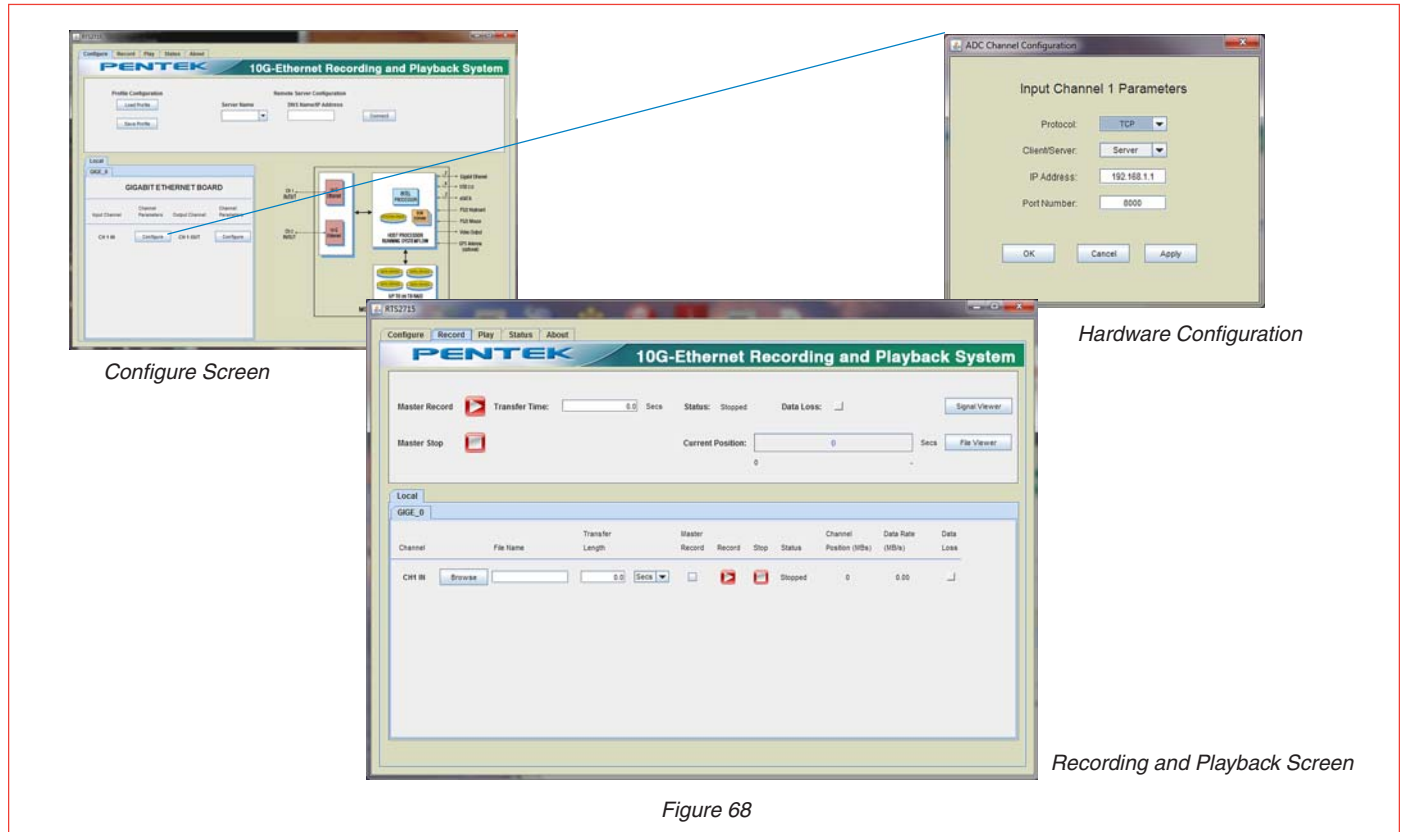

The SystemFlow Software for Digital Recorders provides the user with a control interface for the recording system. It includes Configuration, Record, Playback, and Status screens, each with intuitive controls and indicators.

The user can easily move between screens to set configuration parameters, control and monitor a recording, and play back a recorded stream. All parameters contain limit-checking and integrated help to provide an easier-to-use out-of-the-box experience.

The **Configure Screen** shows a block diagram of the system, and presents operational system parameters including temperature and voltages. Parameters are entered for each input or output channel specifying UDP or TCP protocol, client or server connection, the IP address and port number.

The **Recording and Playback Screen** allows you to browse a folder and enter a file name for the recording. The length of the recording for each channel can be specified in megabytes or in seconds. Intuitive buttons for Record, Pause and Stop simplify operation. Status indicators for each channel display the mode, the number of recorded bytes, and the average data rate. A Data Loss indicator alerts the user to any problem, such as a disk-full condition.

By checking the Master Record boxes, any combination of channels in the lower screen can be grouped for synchronous recording via the upper Master Record screen. The recording time can be specified, and monitoring functions inform the operator of recording progress.

Products

PC Development System for PCIe Cobalt and Onyx Boards

Model 8266

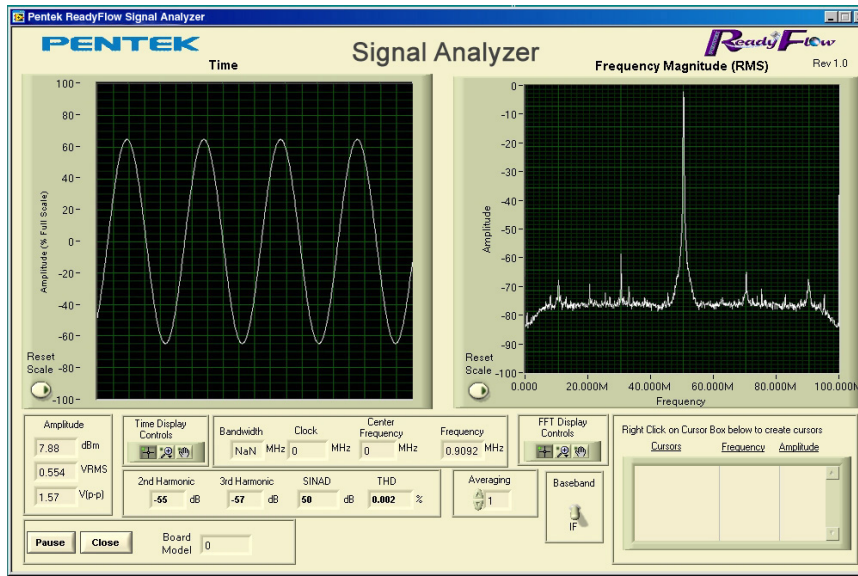

ReadyFlow
Board Support Package

Figure 69

The Model 8266 is a fully-integrated PC development system for Pentek 786xx Cobalt and 787xx Onyx PCI Express software radio, data acquisition, and I/O boards. It was created to save engineers and system integrators the time and expense associated with building and testing a development system that ensures optimum performance of Pentek boards.

A fully-integrated system-level solution, the 8266 provides the user with a streamlined out-of-the-box experience. It comes preconfigured with Pentek hardware, drivers and software examples installed and tested to allow development engineers to run example applications out of the box.

Pentek ReadyFlow drivers and board support libraries are preinstalled and tested with the 8266. ReadyFlow includes example applications with full source code, a command line interface for custom

control over hardware, and Pentek's Signal Analyzer, a full-featured analysis tool that continuously displays live signals in both time and frequency domains.

Built on a professional 4U rackmount workstation, the 8266 is equipped with the latest Intel processor, DDR3 SDRAM and a high-performance motherboard. These features accelerate application code development and provide unhindered access to the high-bandwidth data available with Cobalt and Onyx analog and digital interfaces. The 8266 can be configured with 64-bit Windows or Linux operating systems.

The 8266 uses a 19" 4U rackmount chassis that is 21" deep. Enhanced forced-air ventilation assures adequate cooling for Pentek Cobalt and Onyx boards. A 1000-W power supply guarantees more than enough power for additional boards.

Products

Bandit Modular Analog RF Slot Receivers and Downconverters

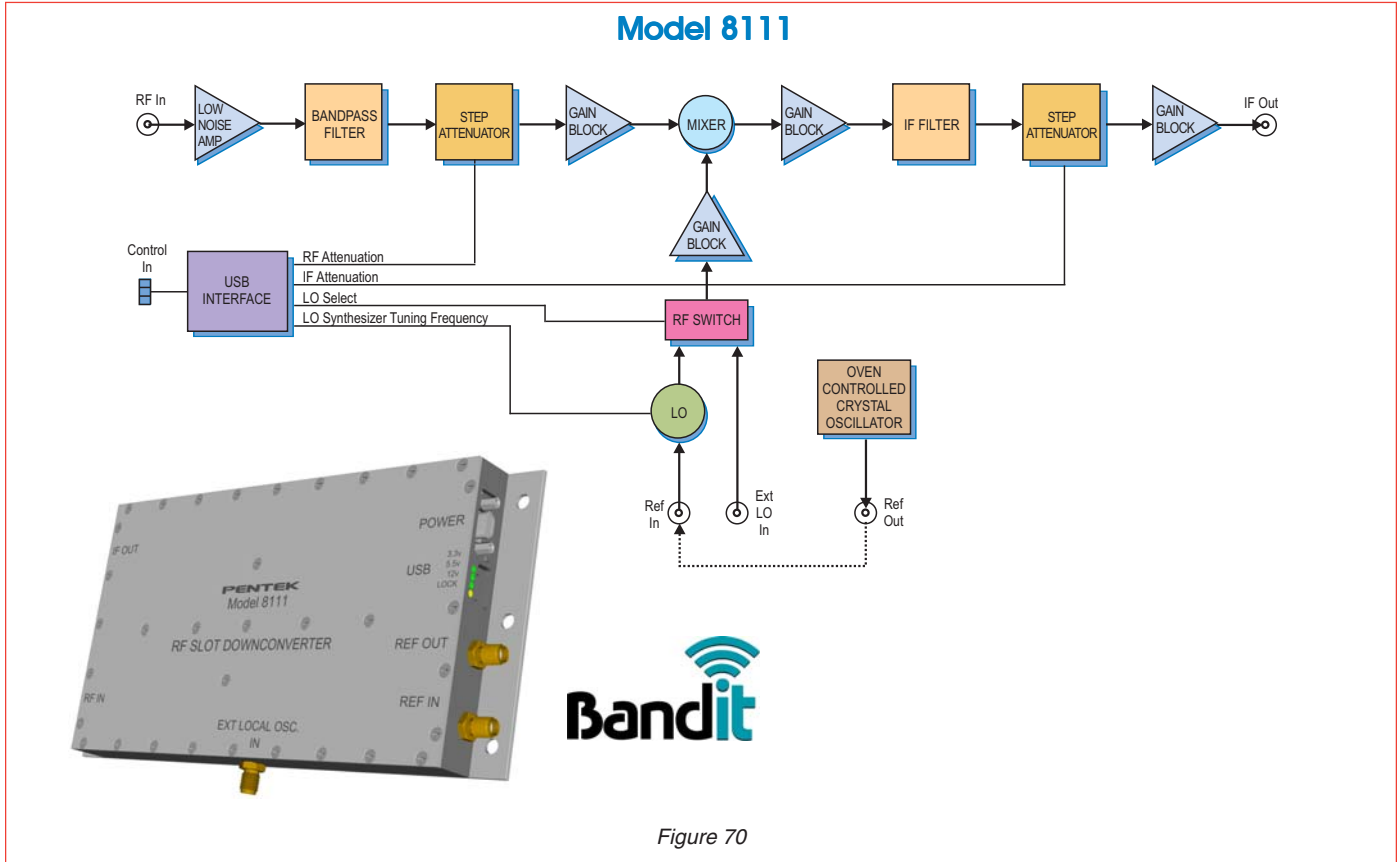

The Bandit® Model 8111 provides a series of high-performance, stand-alone RF slot receiver modules. Packaged in a small, shielded enclosure with connectors for easy integration into RF systems, the modules offer programmable gain, high dynamic range and a low noise figure. With input options to cover specific frequency bands of the RF spectrum, and an IF output optimized for A/D converters, the 8111 is an ideal solution for amplifying and down-converting antenna signals for communications, radar and signal intelligence systems.

The 8111 accepts RF signals on a front panel SMA connector. An LNA (Low Noise-figure Amplifier) is provided along with two programmable attenuators allowing downconversion of input signals ranging from -60 dBm to -20 dBm in steps of 0.5 dB. Higher level signals can be attenuated prior to input.

Seven different input-frequency band options are offered, each tunable across a 400 MHz band, with an overlap of 100 MHz between adjacent bands. As a group, these seven options accommodate RF input signals from 800 MHz to 3.000 GHz as follows:

Option	Frequency Band
001	800-1200 MHz
002	1100-1500 MHz
003	1400-1800 MHz
004	1700-2100 MHz
005	2000-2400 MHz
006	2300-2700 MHz
007	2600-3000 MHz

An 80 MHz wide IF output is provided at a 225 MHz center frequency. This output is suitable for A/D conversion using Pentek high-performance signal acquisition products, such as those in the Cobalt and Onyx families.

Applications

64-Channel Software Radio Recording System

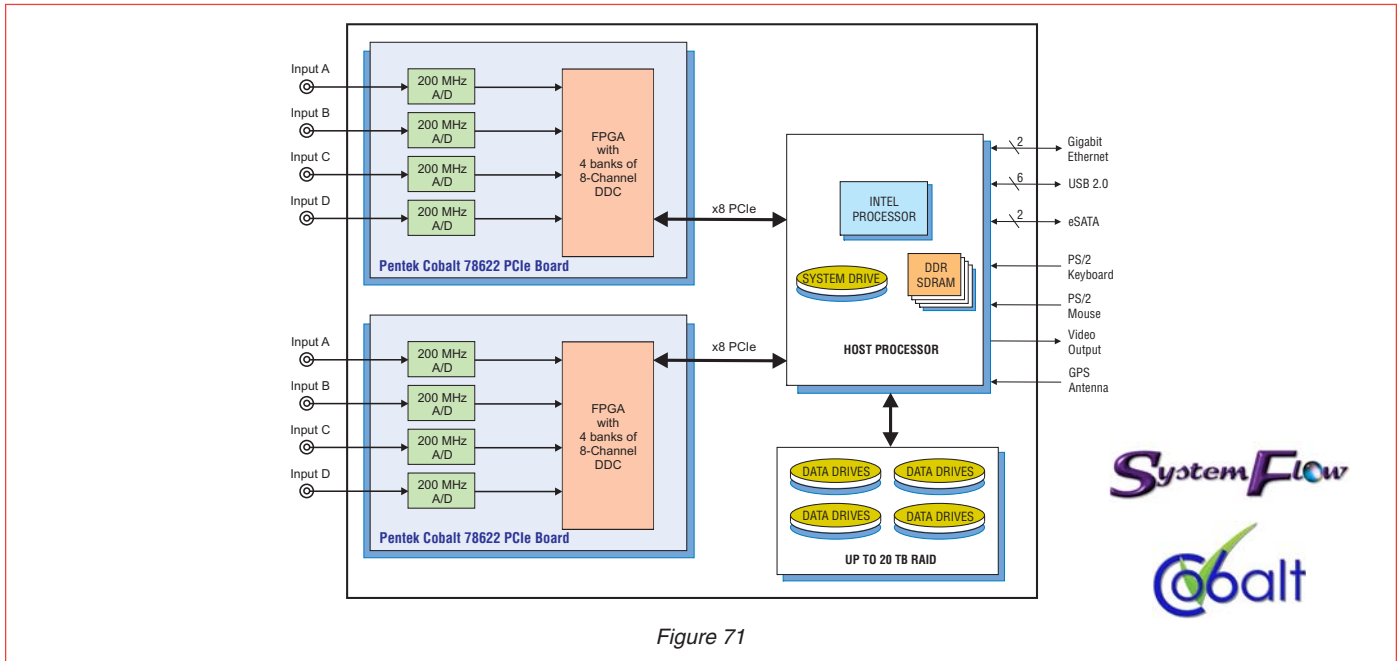

Figure 71

Shown above is a 64-channel recording system utilizing two Pentek Cobalt 78662 PCIe boards. The 78662 samples four input channels at up to 200 megasamples per second, thereby accommodating input signals with up to 80 MHz bandwidth.

Factory-installed in the FPGA of each 78662 is a powerful DDC IP core containing 32 channels. Each of the 32 channels has an independent 32-bit tuning frequency setting that ranges from DC to f_s , where f_s is the A/D sampling frequency. All of the 8 channels within each bank share a common decimation setting that can range from 16 to 8192, programmable in steps of 8. For example, with a sampling rate of 200 MHz, the available output bandwidths range from 19.53 kHz to 10.0 MHz. Each 8-channel bank can have its own unique decimation setting supporting a different bandwidth associated with each of the four acquisition modules.

The decimating filter for each DDC bank accepts a unique set of user-supplied 18-bit coefficients. The 80% default filters deliver an output bandwidth of $0.8 \cdot f_s / N$, where N is the decimation setting. The rejection of adjacent-band components within the 80% output bandwidth is better than 100 dB.

Each DDC delivers a complex output stream consisting of 24-bit I + 24-bit Q samples at a rate of f_s / N . Any number of channels can be enabled within each bank, selectable from 0 to 8. Each bank includes an output sample interleaver that delivers a channel-multiplexed stream for all enabled channels within a bank.

An internal timing bus provides all timing and synchronization required by the eight A/D converters. It includes a clock, two sync and two gate or trigger signals. An on-board clock generator receives an external sample clock. This clock can be used directly by the A/D or divided by a built-in clock synthesizer circuit.

Built on a Windows 7 Professional workstation with high performance Intel® Core™ i7 processor this system allows the user to install post processing and analysis tools to operate on the recorded data. The system records data to the native NTFS file system, providing immediate access to the recorded data.

Included with this system is Pentek's SystemFlow recording software. Optional GPS time and position stamping allows the user to record this critical signal information.

Applications

L-Band Signal Processing System

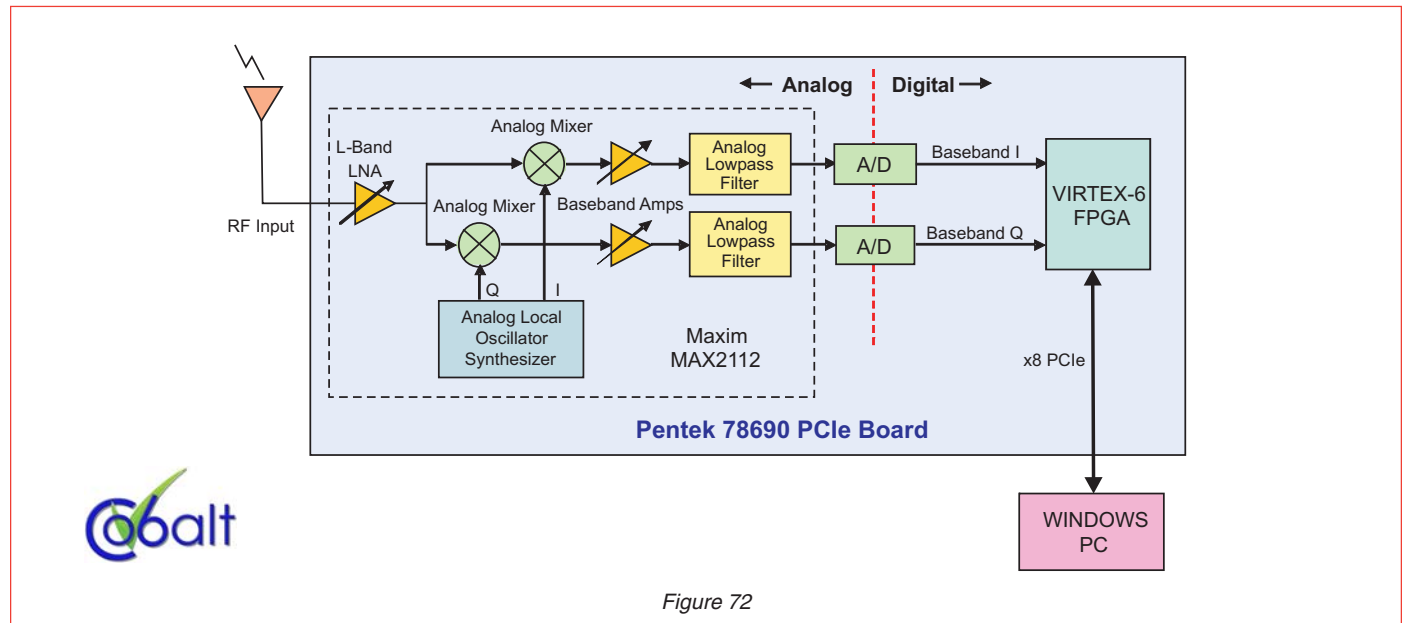

Figure 72

The Cobalt Model 78690 L-Band RF Tuner targets reception and processing of digitally-modulated RF signals such as satellite television and terrestrial wireless communications. The 78690 requires only an antenna and a host computer to form a complete L-band SDR development platform.

This system receives L-Band signals between 925 MHz and 2175 MHz directly from an antenna. Signals above this range such as C Band, Ku Band and K band can be downconverted to L-Band through an LNB (Low Noise Block) downconverter installed in the receiving antenna.

The Maxim Max2112 L-Band Tuner IC features a low-noise amplifier with programmable gain from 0 to 65 dB and a synthesized local oscillator programmable from 925 to 2175 MHz. The complex analog mixer translates the input signals down to DC. Baseband amplifiers provide programmable gain from 0 to 15 dB in steps of 1 dB. The bandwidth of the baseband lowpass filters can be programmed from 4 to 40 MHz. The Maxim IC accommodates full-scale input levels of -50 dBm to +10 dbm and delivers I and Q complex baseband outputs.

The complex I and Q outputs are digitized by two 200 MHz 16-bit A/D converters operating synchronously.

The Virtex-6 FPGA is a powerful resource for recovering and processing a wide range of signals while supporting decryption, decoding, demodulation, detection, and analysis. It is ideal for intercepting or monitoring traffic in SIGINT and COMINT applications. Other applications that benefit include mobile phones, GPS, satellite terminals, military telemetry, digital video and audio in TV broadcasting satellites, and voice, video and data communications.

This L-Band signal processing system is ideal as a front end for government and military systems. Its small size addresses space-limited applications. Ruggedized options are also available from Pentek with the Models 71690 XMC module and the 53690 OpenVPX board to address UAV applications and other severe environments.

Development support for this system is provided by the Pentek ReadyFlow board support package for Windows, Linux and VxWorks. Also available is the Pentek GateFlow FPGA Design Kit to support custom algorithm development.

Applications

8-Channel OpenVPX Beamforming System

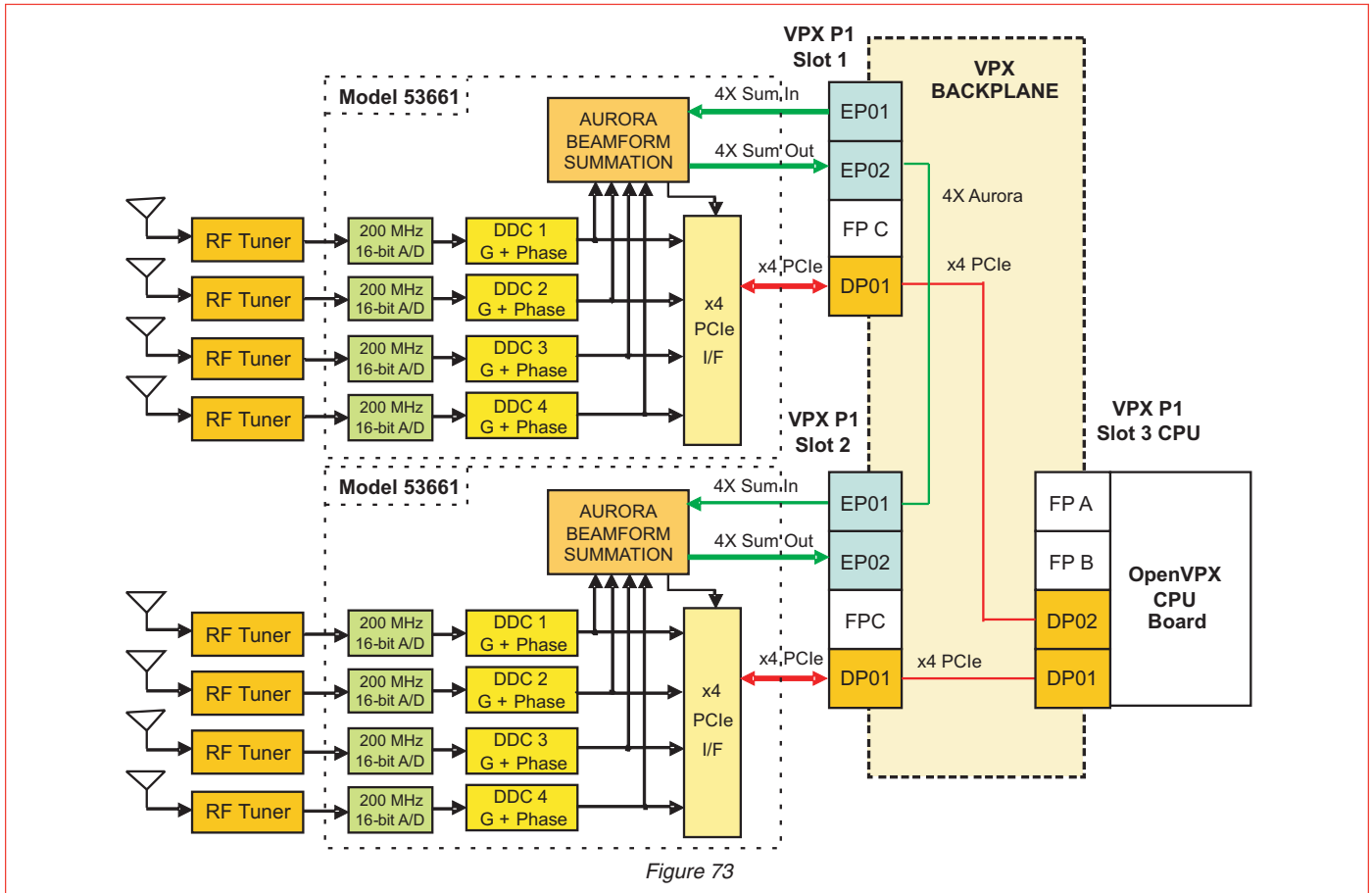

Two Model 53661 boards are installed in slots 1 and 2 of an OpenVPX backplane, along with a CPU board in slot 3. Eight dipole antennas designed for receiving 2.5 GHz signals feed RF Tuners containing low noise amplifiers, local oscillators and mixers. The RF Tuners translate the 2.5 GHz antenna frequency signal down to an IF frequency of 50 MHz.

The 200 MHz 16-bit A/Ds digitize the IF signals and perform further frequency downconversion to baseband, with a DDC decimation of 128. This provides I+Q complex output samples with a bandwidth of about 1.25 MHz. Phase and gain coefficients for each channel are applied to steer the array for directionality.

The CPU board in VPX slot 3 sends commands and coefficients across the backplane over two x4 PCIe links, or OpenVPX “fat pipes”.

The first four signal channels are processed in the upper left 53661 board in VPX slot 1, where the 4-channel beamformed sum is propagated through the 4X Aurora Sum Out link across the backplane to the 4X Aurora Sum In port on the second 53661 in slot 2. The 4-channel local summation from the second 53661 is added to the propagated sum from the first board to form the complete 8-channel sum. This final sum is sent across the x4 PCIe link to the CPU card in slot 3.

Assignment of the three OpenVPX 4X links on the Model 53661 boards is simplified through the use of a crossbar switch which allows the 53661 to operate with a wide variety of different backplanes.

Because OpenVPX does not restrict the use of serial protocols across the backplane links, mixed protocol architectures like the one shown are fully supported. ➤

Applications

8-Channel OpenVPX Beamforming Demo system

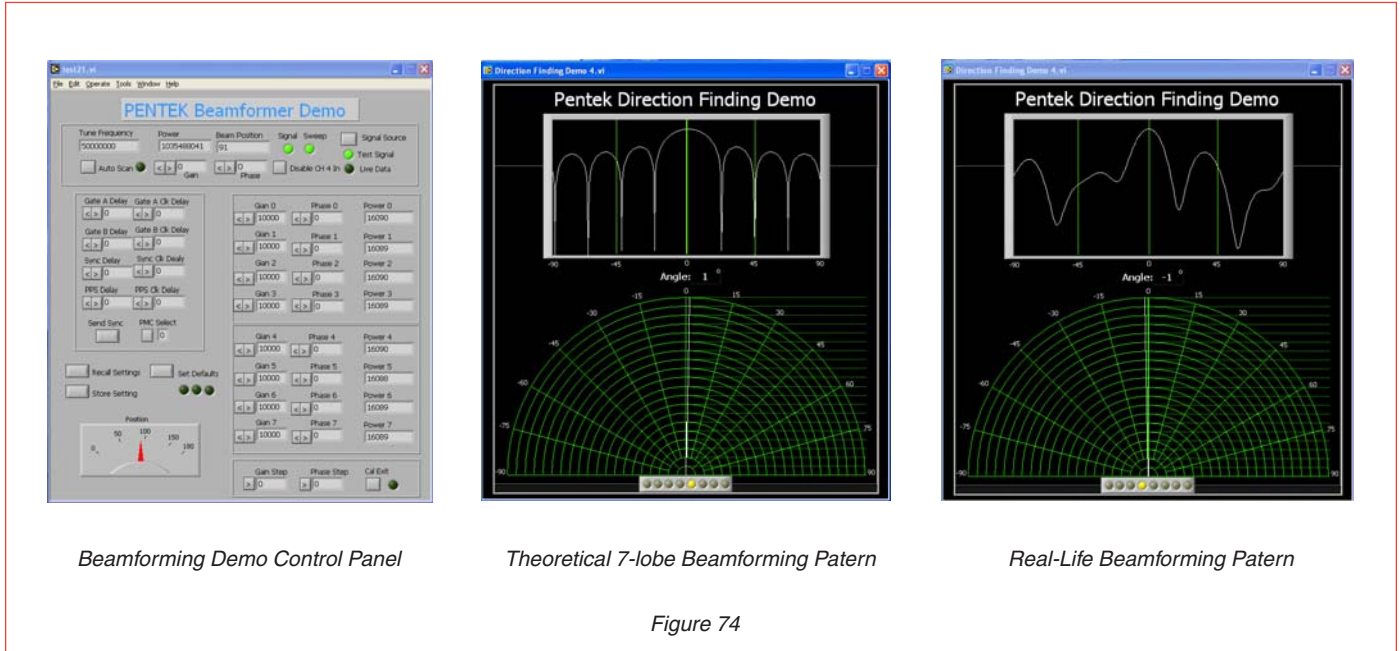

► The beamforming demo system is equipped with a Control Panel that runs under Windows on the CPU board. It includes an automatic signal scanner to detect the strongest signal frequency arriving from a test transmitter. This frequency is centered around the 50 MHz IF frequency of the RF downconverter. Once the frequency is identified, the eight DDCs are set accordingly to bring that signal down to 0 Hz for summation.

The control panel software also allows specific hardware settings for all of the parameters for the eight channels including gain, phase, and sync delay.

An additional display shows the beam-formed pattern of the array. This display is formed by adjusting the phase shift of each of the eight channels to provide maximum sensitivity across arrival angles from -90° to $+90^{\circ}$ perpendicular to the plane of the array.

The classic 7-lobe pattern for an ideal 8-element array for a signal arriving at 0° angle (directly in front of the array) is shown above. Below the lobe pattern is a polar plot showing a single vector pointing to the computed angle of arrival. This is derived from identifying the lobe with the maximum response.

An actual plot of a real-life transmitter is also shown for a source directly in front of the display. In this case the perfect lobe pattern is affected by physical objects, reflections, cable length variations and minor differences in the antennas. Nevertheless, the directional information is computed quite well. As the signal source is moved left and right in front of the array, the peak lobe moves with it, changing the computed angle of arrival.

This demo system is available online at Pentek. If you are interested in viewing a live demonstration, please let us know of your interest by clicking on this link:

[Beamforming Demo.](#)

Links



The following links provide you with additional information about the Pentek products presented in this handbook: just click on the model number. Links are also provided to other handbooks or catalogs that may be of interest in your software radio development projects.

Model	Description	Page
7142	Multichannel Transceiver with Virtex-4 FPGAs - PMC/XMC	15
7242	Multichannel Transceiver with Virtex-4 FPGAs - 6U cPCI	15
7342	Multichannel Transceiver with Virtex-4 FPGAs - 3U cPCI	15
7642	Multichannel Transceiver with Virtex-4 FPGAs - PCI	15
7742	Multichannel Transceiver with Virtex-4 FPGAs - Full-length PCIe	15
7842	Multichannel Transceiver with Virtex-4 FPGAs - Half-length PCIe	15
5342	Multichannel Transceiver with Virtex-4 FPGAs - 3U VPX	15
7142-428	Multichannel Transceiver w. Four Multiband DDCs and Interpolation Filter - PMC/XMC	16
7242-428	Multichannel Transceiver w. Four Multiband DDCs and Interpolation Filter- 6U cPCI	16
7342-428	Multichannel Transceiver w. Four Multiband DDCs and Interpolation Filter- 3U cPCI	16
7642-428	Multichannel Transceiver w. Four Multiband DDCs and Interpolation Filter- PCI	16
7742-428	Multichannel Transceiver w. Four Multiband DDCs and Interpolation Filter- Full-length PCIe	16
7842-428	Multichannel Transceiver w. Four Multiband DDCs and Interpolation Filter- Half-length PCIe	16
5342-428	Multichannel Transceiver w. Four Multiband DDCs and Interpolation Filter- 3U VPX	16
7150	Quad 200 MHz, 16-bit A/D with Virtex-5 FPGAs - PMC/XMC	17
7250	Quad 200 MHz, 16-bit A/D with Virtex-5 FPGAs - 6U cPCI	17
7350	Quad 200 MHz, 16-bit A/D with Virtex-5 FPGAs - 3U cPCI	17
7650	Quad 200 MHz, 16-bit A/D with Virtex-5 FPGAs - PCI	17
7750	Quad 200 MHz, 16-bit A/D with Virtex-5 FPGAs - Full-length PCIe	17
7850	Quad 200 MHz, 16-bit A/D with Virtex-5 FPGAs - Half-length PCIe	17
5350	Quad 200 MHz, 16-bit A/D with Virtex-5 FPGAs - 3U VPX	17
7151	256-Channel DDC with Quad 200 MHz, 16-bit A/D - PMC	18
7251	256-Channel DDC with Quad 200 MHz, 16-bit A/D - 6U cPCI	18
7351	256-Channel DDC with Quad 200 MHz, 16-bit A/D - 3U cPCI	18
7651	256-Channel DDC with Quad 200 MHz, 16-bit A/D - PCI	18
7751	256-Channel DDC with Quad 200 MHz, 16-bit A/D - Full-length PCIe	18
7851	256-Channel DDC with Quad 200 MHz, 16-bit A/D - Half-length PCIe	18
5351	256-Channel DDC with Quad 200 MHz, 16-bit A/D - 3U VPX	18
7152	32-Channel DDC with Quad 200 MHz, 16-bit A/D - PMC	19
7252	32-Channel DDC with Quad 200 MHz, 16-bit A/D - 6U cPCI	19
7352	32-Channel DDC with Quad 200 MHz, 16-bit A/D - 3U cPCI	19
7652	32-Channel DDC with Quad 200 MHz, 16-bit A/D - PCI	19
7752	32-Channel DDC with Quad 200 MHz, 16-bit A/D - Full-length PCIe	19
7852	32-Channel DDC with Quad 200 MHz, 16-bit A/D - Half-length PCIe	19
5352	32-Channel DDC with Quad 200 MHz, 16-bit A/D - 3U VPX	19
7153	4-Channel DDC with Quad 200 MHz, 16-bit A/D - PMC/XMC	20
7253	4-Channel DDC with Quad 200 MHz, 16-bit A/D - 6U cPCI	20
7353	4-Channel DDC with Quad 200 MHz, 16-bit A/D - 3U cPCI	20
7653	4-Channel DDC with Quad 200 MHz, 16-bit A/D - PCI	20
7753	4-Channel DDC with Quad 200 MHz, 16-bit A/D - Full-length PCIe	20
7853	4-Channel DDC with Quad 200 MHz, 16-bit A/D - Half-length PCIe	20
5353	4-Channel DDC with Quad 200 MHz, 16-bit A/D - 3U VPX	20

More links on the next page ➤

Links



Model	Description	Page
7156	Dual SDR Transceiver, 400 MHz A/D, 800 MHz D/A, Virtex-5 FPGAs - PMC/XMC	21
7256	Dual SDR Transceiver, 400 MHz A/D, 800 MHz D/A, Virtex-5 FPGAs - 6U cPCI	21
7356	Dual SDR Transceiver, 400 MHz A/D, 800 MHz D/A, Virtex-5 FPGAs - 3U cPCI	21
7656	Dual SDR Transceiver, 400 MHz A/D, 800 MHz D/A, Virtex-5 FPGAs - PCI	21
7756	Dual SDR Transceiver, 400 MHz A/D, 800 MHz D/A, Virtex-5 FPGAs - Full-length PCIe	21
7856	Dual SDR Transceiver, 400 MHz A/D, 800 MHz D/A, Virtex-5 FPGAs - Half-length PCIe	21
5356	Dual SDR Transceiver, 400 MHz A/D, 800 MHz D/A, Virtex-5 FPGAs - 3U VPX	21
7158	Dual SDR Transceiver, 500 MHz A/D, 800 MHz D/A, Virtex-5 FPGAs - PMC/XMC	22
7258	Dual SDR Transceiver, 500 MHz A/D, 800 MHz D/A, Virtex-5 FPGAs - 6U cPCI	22
7358	Dual SDR Transceiver, 500 MHz A/D, 800 MHz D/A, Virtex-5 FPGAs - 3U cPCI	22
7658	Dual SDR Transceiver, 500 MHz A/D, 800 MHz D/A, Virtex-5 FPGAs - PCI	22
7758	Dual SDR Transceiver, 500 MHz A/D, 800 MHz D/A, Virtex-5 FPGAs - Full-length PCIe	22
7858	Dual SDR Transceiver, 500 MHz A/D, 800 MHz D/A, Virtex-5 FPGAs - Half-length PCIe	22
5358	Dual SDR Transceiver, 500 MHz A/D, 800 MHz D/A, Virtex-5 FPGAs - 3U VPX	22
71620	3-Channel 200 MHz A/D, DUC, 2-Channel 800 MHz D/A, Virtex-6 FPGA - XMC	23
78620	3-Channel 200 MHz A/D, DUC, 2-Channel 800 MHz D/A, Virtex-6 FPGA - PCIe	23
52620 & 53620	3-Channel 200 MHz A/D, DUC, 2-Channel 800 MHz D/A, Virtex-6 FPGA - 3U VPX	23
56620	3-Channel 200 MHz A/D, DUC, 2-Channel 800 MHz D/A, Virtex-6 FPGA - AMC	23
72620	3-Channel 200 MHz A/D, DUC, 2-Channel 800 MHz D/A, Virtex-6 FPGA - 6U cPCI	23
73620	3-Channel 200 MHz A/D, DUC, 2-Channel 800 MHz D/A, Virtex-6 FPGA - 3U cPCI	23
74620	6-Channel 200 MHz A/D, DUC, 4-Channel 800 MHz D/A, Two Virtex-6 FPGAs - 6U cPCI	23
71720	3-Channel 200 MHz A/D, DUC, 2-Channel 800 MHz D/A, Virtex-7 FPGA - XMC	24
78720	3-Channel 200 MHz A/D, DUC, 2-Channel 800 MHz D/A, Virtex-7 FPGA - PCIe	24
52720 & 52720	3-Channel 200 MHz A/D, DUC, 2-Channel 800 MHz D/A, Virtex-7 FPGA - 3U VPX	24
56720	3-Channel 200 MHz A/D, DUC, 2-Channel 800 MHz D/A, Virtex-7 FPGA - AMC	24
72720	3-Channel 200 MHz A/D, DUC, 2-Channel 800 MHz D/A, Virtex-7 FPGA - 6U cPCI	24
73720	3-Channel 200 MHz A/D, DUC, 2-Channel 800 MHz D/A, Virtex-7 FPGA - 3U cPCI	24
74720	6-Channel 200 MHz A/D, DUC, 4-Channel 800 MHz D/A, Two Virtex-7 FPGAs - 6U cPCI	24
—	GateXpress for FPGA-PCIE Configuration Management	25
71621	3-Channel 200 MHz A/D, DUC, 2-Channel 800 MHz D/A, Installed IP Cores - XMC	26
78621	3-Channel 200 MHz A/D, DUC, 2-Channel 800 MHz D/A, Installed IP Cores - PCIe	26
52621 & 53621	3-Channel 200 MHz A/D, DUC, 2-Channel 800 MHz D/A, Installed IP Cores - 3U VPX	26
56621	3-Channel 200 MHz A/D, DUC, 2-Channel 800 MHz D/A, Installed IP Cores - AMC	26
72621	3-Channel 200 MHz A/D, DUC, 2-Channel 800 MHz D/A, Installed IP Cores - 6U cPCI	26
73621	3-Channel 200 MHz A/D, DUC, 2-Channel 800 MHz D/A, Installed IP Cores - 3U cPCI	26
74621	6-Channel 200 MHz A/D, DUC, 4-Channel 800 MHz D/A, Installed IP Cores - 6U cPCI	26
78630	1 GHz A/D, 1 GHz D/A, Virtex-6 FPGA - PCIe	27
71630	1 GHz A/D, 1 GHz D/A, Virtex-6 FPGA - XMC	27
52630 & 53630	1 GHz A/D, 1 GHz D/A, Virtex-6 FPGA - 3U VPX	27
56630	1 GHz A/D, 1 GHz D/A, Virtex-6 FPGA - AMC	27
72630	1 GHz A/D, 1 GHz D/A, Virtex-6 FPGA - 6U cPCI	27
73630	1 GHz A/D, 1 GHz D/A, Virtex-6 FPGA - 3U cPCI	27
74630	Two 1 GHz A/Ds, Two 1 GHz D/As, Two Virtex-6 FPGAs - 6U cPCI	27

More links on the next page ➤

Links



Model	Description	Page
72640	1-Channel 3.6 GHz and 2-Channel 1.8 GHz, 12-bit A/D, Virtex-6 FPGA - 6U cPCI	28
73640	1-Channel 3.6 GHz and 2-Channel 1.8 GHz, 12-bit A/D, Virtex-6 FPGA - 3U cPCI	28
74640	2-Channel 3.6 GHz and 4-Channel 1.8 GHz, 12-bit A/D, Virtex-6 FPGAs - 6U cPCI	28
71640	1-Channel 3.6 GHz and 2-Channel 1.8 GHz, 12-bit A/D, Virtex-6 FPGA - XMC	28
78640	1-Channel 3.6 GHz and 2-Channel 1.8 GHz, 12-bit A/D, Virtex-6 FPGA - PCIe	28
52640 & 53640	1-Channel 3.6 GHz and 2-Channel 1.8 GHz, 12-bit A/D, Virtex-6 FPGA - 3U VPX	28
56640	1-Channel 3.6 GHz and 2-Channel 1.8 GHz, 12-bit A/D, Virtex-6 FPGA - AMC	28
56641	1-Channel 3.6 GHz and 2-Channel 1.8 GHz, 12-bit A/D, DDC, Virtex-6 FPGA - AMC	29
71641	1-Channel 3.6 GHz and 2-Channel 1.8 GHz, 12-bit A/D, DDC, Virtex-6 FPGA - XMC	29
78641	1-Channel 3.6 GHz and 2-Channel 1.8 GHz, 12-bit A/D, DDC, Virtex-6 FPGAs - PCIe	29
52641 & 53641	1-Channel 3.6 GHz and 2-Channel 1.8 GHz, 12-bit A/D, DDC, Virtex-6 FPGA - 3U VPX	29
72641	1-Channel 3.6 GHz and 2-Channel 1.8 GHz, 12-bit A/D, DDC, Virtex-6 FPGA - 6U cPCI	29
73641	1-Channel 3.6 GHz and 2-Channel 1.8 GHz, 12-bit A/D, DDC, Virtex-6 FPGA - 3U cPCI	29
74641	2-Channel 3.6 GHz and 4-Channel 1.8 GHz, 12-bit A/D, DDCs, Virtex-6 FPGA - 6U cPCI	29
52650 & 53650	2-Channel 500 MHz A/D, DUC, 2-Channel 800 MHz D/A, Virtex-6 FPGA - 3U VPX	30
71650	2-Channel 500 MHz A/D, DUC, 2-Channel 800 MHz D/A, Virtex-6 FPGA - XMC	30
78650	2-Channel 500 MHz A/D, DUC, 2-Channel 800 MHz D/A, Virtex-6 FPGA - PCIe	30
56650	2-Channel 500 MHz A/D, DUC, 2-Channel 800 MHz D/A, Virtex-6 FPGA - AMC	30
72650	2-Channel 500 MHz A/D, DUC, 2-Channel 800 MHz D/A, Virtex-6 FPGA - 6U cPCI	30
73650	2-Channel 500 MHz A/D, DUC, 2-Channel 800 MHz D/A, Virtex-6 FPGA - 3U cPCI	30
74650	4-Channel 500 MHz A/D, DUC, 4-Channel 800 MHz D/A, Two Virtex-6 FPGAs - 6U cPCI	30
72651	2-Channel 500 MHz A/D, with DDCs, DUC, 2-Channel 800 MHz D/A, Virtex-6 FPGA - 6U cPCI	31
73651	2-Channel 500 MHz A/D, with DDCs, DUC, 2-Channel 800 MHz D/A, Virtex-6 FPGA - 3U cPCI	31
74651	4-Channel 500 MHz A/D, with DDCs, DUCs, 4-Channel 800 MHz D/A, Virtex-6 FPGA - 6U cPCI	31
71651	2-Channel 500 MHz A/D, with DDCs, DUC, 2-Channel 800 MHz D/A, Virtex-6 FPGA - XMC	31
78651	2-Channel 500 MHz A/D, with DDCs, DUC, 2-Channel 800 MHz D/A, Virtex-6 FPGA - PCIe	31
52651 & 53651	2-Channel 500 MHz A/D, with DDCs, DUC, 2-Channel 800 MHz D/A, Virtex-6 FPGA - 3U VPX	31
56651	2-Channel 500 MHz A/D, with DDCs, DUC, 2-Channel 800 MHz D/A, Virtex-6 FPGA - AMC	31
71660	4-Channel 200 MHz 16-bit A/D with Virtex-6 FPGA - XMC	32
78660	4-Channel 200 MHz 16-bit A/D with Virtex-6 FPGA - PCIe	32
52660 & 53660	4-Channel 200 MHz 16-bit A/D with Virtex-6 FPGA - 3U VPX	32
56660	4-Channel 200 MHz 16-bit A/D with Virtex-6 FPGA - AMC	32
72660	4-Channel 200 MHz 16-bit A/D with Virtex-6 FPGA - 6U cPCI	32
73660	4-Channel 200 MHz 16-bit A/D with Virtex-6 FPGAs - 3U cPCI	32
74660	8-Channel 200 MHz 16-bit A/D with Two Virtex-6 FPGAs - 6U cPCI	32
71760	4-Channel 200 MHz 16-bit A/D with Virtex-7 FPGA - XMC	33
78760	4-Channel 200 MHz 16-bit A/D with Virtex-7 FPGA - PCIe	33
52760 & 53760	4-Channel 200 MHz 16-bit A/D with Virtex-7 FPGA - 3U VPX	33
56760	4-Channel 200 MHz 16-bit A/D with Virtex-7 FPGA - AMC	33
72760	4-Channel 200 MHz 16-bit A/D with Virtex-7 FPGA - 6U cPCI	33
73760	4-Channel 200 MHz 16-bit A/D with Virtex-7 FPGA - 3U cPCI	33
74760	8-Channel 200 MHz 16-bit A/D with Two Virtex-7 FPGAs - 6U cPCI	33

More links on the next page ➤

Links



Model	Description	Page
71661	4-Channel 200 MHz 16-bit A/D with Installed IP Cores - XMC	34
78661	4-Channel 200 MHz 16-bit A/D with Installed IP Cores - PCIe	34
52661 & 53661	4-Channel 200 MHz 16-bit A/D with Installed IP Cores - 3U VPX	34
56661	4-Channel 200 MHz 16-bit A/D with Installed IP Cores - AMC	34
72661	4-Channel 200 MHz 16-bit A/D with Installed IP Cores - 6U cPCI	34
73661	4-Channel 200 MHz 16-bit A/D with Installed IP Cores - 3U cPCI	34
74661	8-Channel 200 MHz 16-bit A/D with Installed IP Cores - 6U cPCI	34
78662	4-Channel 200 MHz 16-bit A/D with Installed IP Cores - PCIe	35
71662	4-Channel 200 MHz 16-bit A/D with Installed IP Cores - XMC	35
52662 & 53662	4-Channel 200 MHz 16-bit A/D with Installed IP Cores - 3U VPX	35
56662	4-Channel 200 MHz 16-bit A/D with Installed IP Cores - AMC	35
72662	4-Channel 200 MHz 16-bit A/D with Installed IP Cores - 6U cPCI	35
73662	4-Channel 200 MHz 16-bit A/D with Installed IP Cores - 3U cPCI	35
74662	8-Channel 200 MHz 16-bit A/D with Installed IP Cores - 6U cPCI	35
56670	4-Channel 1.25 GHz D/A with DUC, Virtex-6 FPGA - AMC	36
71670	4-Channel 1.25 GHz D/A with DUC, Virtex-6 FPGA - XMC	36
78670	4-Channel 1.25 GHz D/A with DUC, Virtex-6 FPGA - PCIe	36
52670 & 53670	4-Channel 1.25 GHz D/A with DUC, Virtex-6 FPGA - 3U VPX	36
72670	4-Channel 1.25 GHz D/A with DUC, Virtex-6 FPGA - 6U cPCI	36
73670	4-Channel 1.25 GHz D/A with DUC, Virtex-6 FPGA - 3U cPCI	36
74670	8-Channel 1.25 GHz D/A with DUCs, and Two Virtex-6 FPGAs - 6U cPCI	36
71671	4-Channel 1.25 GHz D/A with DUC, Extended Interpolation, Virtex-6 FPGA - XMC	37
78671	4-Channel 1.25 GHz D/A with DUC, Extended Interpolation, Virtex-6 FPGA - PCIe	37
52671 & 53671	4-Channel 1.25 GHz D/A with DUC, Extended Interpolation, Virtex-6 FPGA - 3U VPX	37
56671	4-Channel 1.25 GHz D/A with DUC, Extended Interpolation, Virtex-6 FPGA - AMC	37
72671	4-Channel 1.25 GHz D/A with DUC, Extended Interpolation, Virtex-6 FPGA - 6U cPCI	37
73671	4-Channel 1.25 GHz D/A with DUC, Extended Interpolation, Virtex-6 FPGA - 3U cPCI	37
74671	8-Channel 1.25 GHz D/A with DUCs, Ext. Interpolation, Two Virtex-6 FPGAs - 6U cPCI	37
53690 & 52690	L-Band RF Tuner with 2-Channel 200 MHz A/D and Virtex-6 FPGA - 3U VPX	38
71690	L-Band RF Tuner with 2-Channel 200 MHz A/D and Virtex-6 FPGA - XMC	38
78690	L-Band RF Tuner with 2-Channel 200 MHz A/D and Virtex-6 FPGA - PCIe	38
56690	L-Band RF Tuner with 2-Channel 200 MHz A/D and Virtex-6 FPGA - AMC	38
72690	L-Band RF Tuner with 2-Channel 200 MHz A/D and Virtex-6 FPGA - 6U cPCI	38
73690	L-Band RF Tuner with 2-Channel 200 MHz A/D and Virtex-6 FPGA - 3U cPCI	38
74690	Dual L-Band RF Tuner with 4-Channel 200 MHz A/D and Two Virtex-6 FPGAs - 6U cPCI	38
6890	2.2 GHz Clock, Sync and Gate Distribution Board - VME	39
6891	System Synchronizer and Distribution Board - VME	40
7190	Multifrequency Clock Synthesizer - PMC	41
7290	Multifrequency Clock Synthesizer - 6U cPCI	41
7390	Multifrequency Clock Synthesizer - 3U cPCI	41
7690	Multifrequency Clock Synthesizer - PCI	41
7790	Multifrequency Clock Synthesizer - Full-length PCIe	41
7890	Multifrequency Clock Synthesizer - Half-length PCIe	41
5390	Multifrequency Clock Synthesizer - 3U VPX	41

More links on the next page ►

Links



Model	Description	Page
7191	Programmable Multifrequency Clock Synthesizer - PMC	42
7291	Programmable Multifrequency Clock Synthesizer - 6U cPCI	42
7391	Programmable Multifrequency Clock Synthesizer - 3U cPCI	42
7691	Programmable Multifrequency Clock Synthesizer - PCI	42
7791	Programmable Multifrequency Clock Synthesizer - Full-length PCIe	42
7891	Programmable Multifrequency Clock Synthesizer - Half-length PCIe	42
5391	Programmable Multifrequency Clock Synthesizer - 3U VPX	42
7192	High-Speed Synchronizer and Distribution Board - PMC/XMC	43
7892	High-Speed Synchronizer and Distribution Board - PCIe	43
5292	High-Speed Synchronizer and Distribution Board - 3U VPX	43
7292	High-Speed Synchronizer and Distribution Board - 6U cPCI	43
7392	High-Speed Synchronizer and Distribution Board - 3U cPCI	43
7492	High-Speed Synchronizer and Distribution Board - 6U cPCI	43
7893	System Synchronizer and Distribution Board - PCIe	44
7194	High-Speed Clock Generator - PMC/XMC	45
7894	High-Speed Clock Generator - PCIe	45
5294	High-Speed Clock Generator - 3U VPX	45
5694	High-Speed Clock Generator - AMC	45
7294	High-Speed Clock Generator - 6U cPCI	45
7394	High-Speed Clock Generator - 3U cPCI	45
7494	High-Speed Clock Generator- 6U cPCI	45
9190	Clock and Sync Generator for I/O Modules - Rackmount	46
9192	High-Speed System Synchronizer Unit - Rackmount	47
RTS 2706	Eight-Channel RF/IF 200 MS/sec Rackmount Recorder	48
RTS 2707	Four-Channel RF/IF 500 MS/sec Rackmount Recorder	49
RTS 2709	Ultra Wideband One- or Two-Channel RF/IF, 3.2 GS/sec Rackmount Recorder	50
RTS 2715	Two-Channel 10 Gigabit Ethernet Rackmount Recorder	51
RTS 2716	Eight-Channel Serial FPDP Rackmount Recorder	52
RTS 2718	LVDS Digital I/O Rackmount Recorder	53
RTR 2726	Four-Channel RF/IF 200 MS/sec Rugged Portable Recorder	54
RTR 2727	Two-Channel RF/IF 500 MS/sec Rugged Portable Recorder	55
RTR 2736	Eight-Channel Serial FPDP Rugged Portable Recorder	56
RTR 2738	LVDS Digital I/O Rugged Portable Recorder	57
RTR 2746	Eight-Channel RF/IF 200 MS/sec Rugged Rackmount Recorder	58
RTR 2747	Four-Channel RF/IF 500 MS/sec Rugged Rackmount Recorder	59
RTR 2749	Ultra Wideband One- or Two-Channel RF/IF, 3.2 GS/sec Rugged Rackmount Recorder	60
RTR 2755	Two-Channel 10 Gigabit Ethernet Rugged Rackmount Recorder	61
RTR 2756	Eight-Channel Serial FPDP Rugged Rackmount Recorder	62
RTR 2758	LVDS Digital I/O Rugged Rackmount Recorder	63
RTX 2786	Four-Channel RF/IF 200 MS/sec Extreme 3U VPX Recorder	64
8266	PC Development System for PCIe Cobalt and Onyx Boards	67
8111	Bandit Modular Analog RF Slot Receivers and Downconverters	68

More links on the next page ►

Links



Other Handbooks and Catalogs

Click here	Software Defined Radio Handbook
Click here	Critical Techniques for High-Speed A/D Converters in Real-Time Systems Handbook
Click here	High-Speed Switched Serial Fabrics Improve System Design Handbook
Click here	High-Speed, Real-Time Recording Systems Handbook
Click here	Onyx Virtex-7 and Cobalt Virtex-6 Product Catalog
Click here	Pentek Product Catalog