



High-Speed, Real-Time Recording Systems

First Edition

Recording Systems

Talon™ Recorders

Application

Appendix A: High-Speed A/D Converters

Appendix B: Switched Serial Fabrics

Links

by

Rodger H. Hosking

Vice-President & Cofounder of Pentek, Inc.

Pentek, Inc.

One Park Way, Upper Saddle River, New Jersey 07458

Tel: (201) 818-5900 • Fax: (201) 818-5904

Email: info@pentek.com • <http://www.pentek.com>

Copyright © 2011 Pentek Inc.
Last updated: December 2011
All rights reserved.

Contents of this publication may not be reproduced in any form without written permission.
Specifications are subject to change without notice.

Pentek, GateFlow, ReadyFlow and VIM are registered trademarks of Pentek, Inc.

Preface

In today's world of high-speed A/D converters operating in the gigahertz range, real-time signal recording has become a challenging task that requires specialized hardware and intelligent application software. When designing a real-time recorder capable of streaming sustained data to disk at rates of up to 2 GB/sec and higher, the system developer has to consider the limitations presented by the recorder's operating and file systems, the limitations of disk drive technology, the hardware interfaces, and the RAID controller technology.

Fortunately for the application developer, serial fabrics have emerged to provide the high-speed interfaces required to move this data; disk drive and RAID HBAs (Host-Bus Adapters) have begun to exploit serial interfaces; finally, the emergence of SSD (Solid State Drive) technology provides a performance level previously unattainable in real-time recording systems. Developing software that can take advantage of these new technologies presents a challenge that can be met by understanding some key concepts required to build a high-speed, real-time recording system.

In this handbook, we will look at some of these techniques and will discuss some of the features that are widely desired in such a system, including the use of a non-proprietary file system, the use of a client-server architecture, and the presence of a user-friendly API (Application Programming Interface). Finally, we will highlight the latest Pentek Talon™ High-Speed Recording and Playback Systems and an application based on one of them.

*More information on high-speed A/Ds is presented in our **Critical Techniques for High-Speed A/D Converters in Real-Time Systems** handbook.*

*More information on high-speed interfaces and gigabit serial links is presented in our **Switched Serial Fabrics Improve System Design** handbook.*

Links to download these and our other handbooks are included on the last page of this handbook.

Recording Systems

Introduction

- Desired sustained data transfers up to 2 GB/sec
- Limitations to such transfers are presented by the:
 - Operating system
 - File system
 - Disk drive technology
 - Hardware interfaces
 - RAID controller technology
- Serial fabrics and RAID HBAs provide the high-speed interfaces to move this data
- Solid State Drives provide performance levels previously unattainable

Figure 1

When designing a real-time recording system capable of streaming sustained data to disk at rates of up to 2 GB/sec, the system developer has to consider the limitations presented by the recorder's operating and file systems, the limitations of disk drive technology, the hardware interfaces, and the RAID controller technology.

The high-speed A/D converters we review in Appendix A that operate at sampling frequencies in excess of 100 MHz, present real-time signal recording with a challenging task that requires specialized hardware and intelligent application software.

Fortunately for the application developer, the serial fabrics we present in Appendix B provide the high-speed interfaces required to move this data.

The disk drive and RAID HBAs (Host-Bus Adapters) we will discuss in this chapter also exploit serial interfaces; finally, the emergence of solid-state drive technology provides a performance level previously unattainable in real-time recording systems.

Developing software that can take advantage of these new technologies presents a challenge that can be met by understanding some key concepts required to build a real-time recording system.

Real-Time Recording

- Real-Time recording captures every sample provided by the front-end without loss
- Desire to move data faster today than could be done yesterday
- The commercial server PC market provides an excellent choice as a recording platform
- CPU technology is constantly advancing in architecture and processing speed
- Memory interfaces can stream data at 10 GB/sec
- Serial fabrics provide PCI Express capable of data rates of 8 GB/sec

Figure 2

In order for a recording system to be considered "real-time", it must capture every sample of data provided by the front-end with absolutely no loss. This must happen consistently to create confidence that the system will perform in the most mission-critical situations.

When choosing a platform to develop the recording system, it is important to consider the constant requirement to move data faster today than could be done yesterday. With this in mind, the commercial server PC market provides an excellent platform choice as it benefits from the consumer-driven requirement to move, process and store greater and greater amounts of data every day.

Within the server PC, microprocessor technology is constantly advancing in both processing speed and in architecture. Memory interfaces are capable of streaming data at rates of 10 GB/sec and higher. Serial fabrics have provided PCI Express Gen. 2 with x16 interfaces capable of maximum data rates of 8 GB/sec. Finally, SATA II provides disk storage rates of 3 Gb/sec to a single drive.

The latest Intel processors are approaching 4 GHz clock rates with hex and octal cores, while memory continues to get smaller, cheaper and faster. This provides us with a solid foundation to build on, one that we can grow with as new high-speed digitizers are introduced.

Recording Systems

Recording System Overview

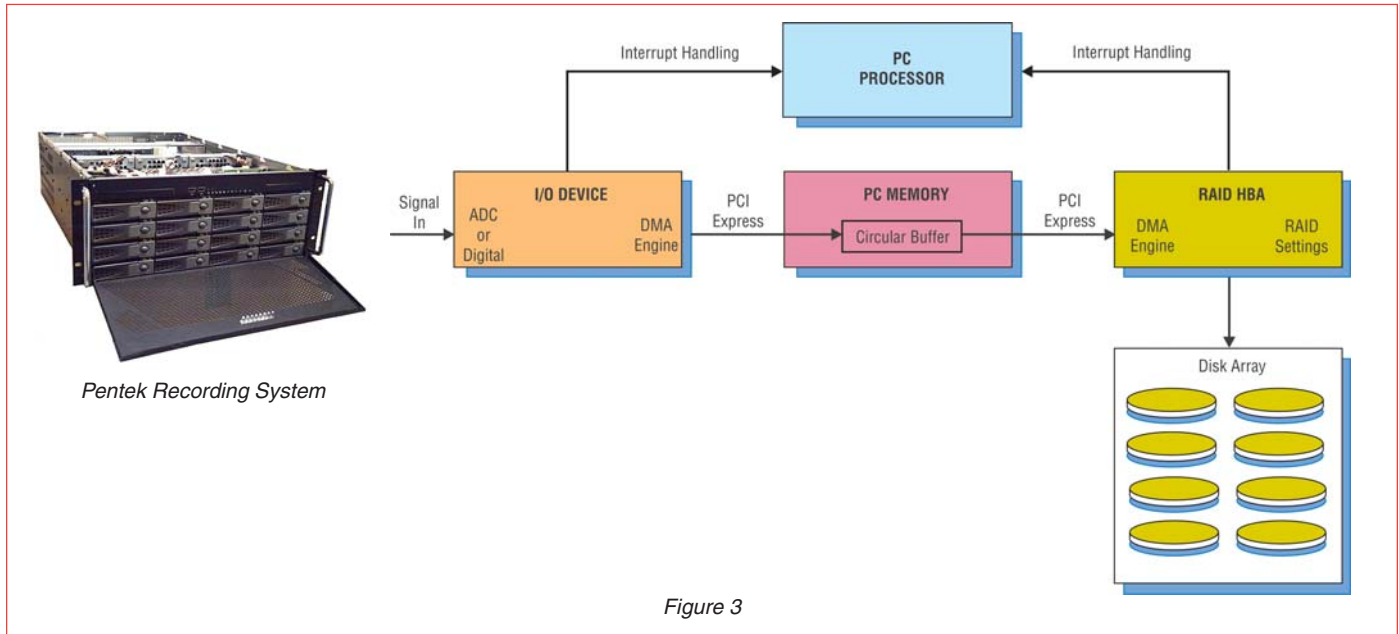

Once the foundation of our recorder is established, it is essential to provide a front-end I/O device that is capable of streaming data in real-time. As shown in the above figure, this front-end device typically consists of one or more high-speed A/D converters or digital interfaces that acquire data at a constant rate, and a set of DMA engines that move data off the device. In a real-time system, these DMA engines are the most critical feature of the I/O device, since their design dictates how well this hardware can stream the data and maintain its real-time performance requirement.

While the DMA engines are responsible for moving data off the device, it is the PCI Express engine, inherent within the device that provides the path to the server PC's system memory. It is here that the data is buffered and made available to the storage device. The server PC's PCIe interface is the path from the I/O device to the system's memory. It is essential that our I/O device provides a sufficiently fast PCIe interface with the bandwidth required to maintain the data rates of the front-end.

It is also essential that the I/O device has the ability to stream data continuously with no software interven-

tion, allowing the hardware to be solely responsible for the data movement. The latest high-performance I/O devices provide intelligent DMA chaining that allow the system developer to custom-tailor the data flow to maximize performance and assure the system meets the real-time requirements.

The DMA engine should allow the user to chain large buffers of data and should provide many chains in a link list. If this is provided, it is the application developer's responsibility to create a large circular buffer, consisting of many chains, each of considerable size. Buffering this data in such a way will allow the system to absorb any momentary latency hits, which can be caused by a number of external factors.

Buffered data must be sent to disk at data rates that match those of the front end I/O device. Utilizing off-the-shelf high-performance RAID HBAs, allows the developer to take advantage of the inherent features and functionality provided, including selectable RAID-level control and automated disk recovery facilities. The challenge in selecting the best RAID controller lies in finding one that reliably meets the sustained streaming read/write requirements of the system.

Recording Systems

Hard Disk Drive



Figure 4

A hard disk drive (HDD or hard drive or hard disk) is a non-volatile, random access digital data storage device. It features rotating rigid platters on a motor-driven spindle within a protective enclosure. Data is magnetically read from and written to the platter by read/write heads that float on a film of air above the platters.

Hard disk drives have decreased in cost and physical size over the years while dramatically increasing in capacity. Hard disk drives have been the dominant device for data storage in general-purpose computers since the early 1960s. They have maintained this position because advances in their recording density have kept pace with storage requirements. Today's HDDs operate on high-speed serial interfaces, such as SATA (Serial ATA).

The factors that limit the time to access the data on a hard disk drive are mostly related to the mechanical nature of the rotating disks and moving heads. Seek time is a measure of how long it takes the head assembly to travel to the track of the disk that contains data. Rotational latency is incurred because the desired disk sector may not be directly under the head when data transfer is requested. These two delays are on the order of milliseconds each.

HDD Read/Write Rates

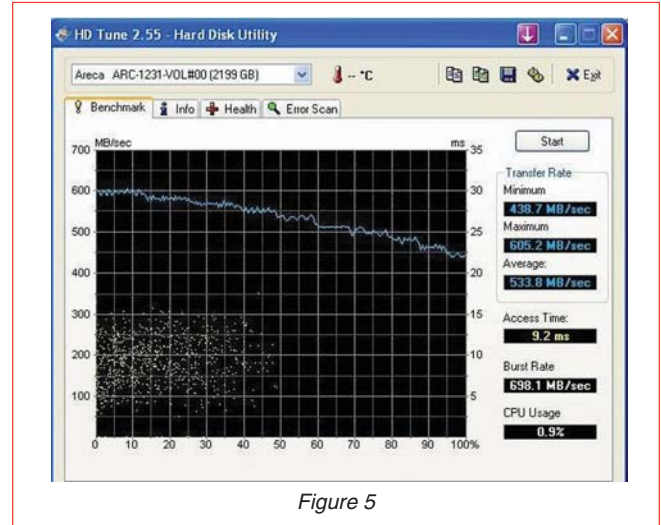

Figure 5

When developing a recording system, it is important to recognize the non-linearity of the HDD.

Since the density of an HDD remains constant through the disk and the rotation speed remains constant, the read and write rates of a disk fall as HDD accesses move from the outer edge of the disk to the inner edge. This is due to the fact that the circumference of the outer edge of a disk is longer than the circumference of the inner edge. Since the disk rotates at the same speed for either edge and the density is the same, the disk will provide many more bytes per second on the outer edge than the inner edge.

Since disks present their logical addressing from the outer edge to the inner edge, disk read and write rates fall as a disk fills up. This can be seen in the above screen plot. RAID*s built on several HDDs, provide a similar non-linearity in their data rates. Because of this, it is imperative that the system developer either provide enough drives in the RAID to meet the maximum data-rate requirement for the entire volume, or limit the size of the drive volume to the percentage of disk space that will meet the system's data-rate requirement.

* RAID, acronym for Redundant Array of Independent Disks, is a storage technology that provides increased reliability and functions through redundancy.

Recording Systems

RAID Array

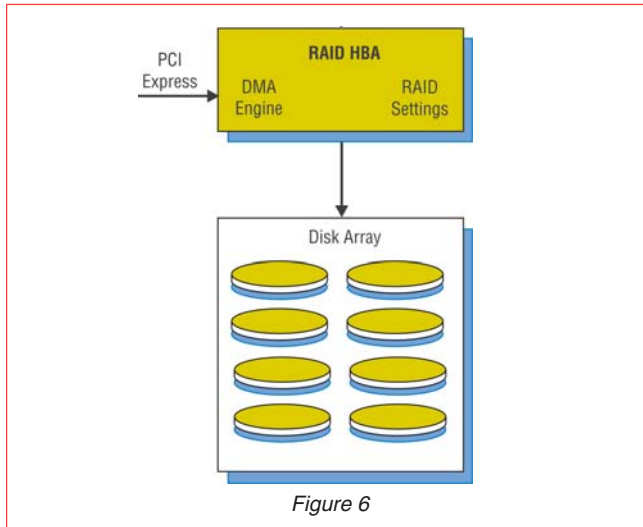

As we said previously, RAID arrays built on several HDDs display a similar non-linearity in data rates.

For example, let's consider the case of designing a recording system that would maintain 500 MB/sec data transfer rates. The drive volume should be formatted to use about 50% of the available disk capacity. This is done simply by formatting the drive to the appropriate size within the operating system.

It is important to leave a sufficient amount of overhead, when selecting the formatted disk amount. In this case, while the system may keep up with the 500 MB/sec requirement for almost seventy percent of the drive volume, fifty percent is a much safer number, provided it supplies enough storage for the application.

There are other critical factors to consider to assure real-time performance when designing a recording system. When dealing with non-real-time operating systems like Windows and Linux, it is important to minimize the operating system's impact on the recording application. The amount of processor intervention in the recording software can be minimized by dedicating the data transfers to the DMA controllers and simply leaving the processor to manage the data flow. The developer should also elevate the priorities of real-time tasks within the application and keep background tasks at lower priorities to avoid impacting the recorder's performance.

Solid-State Drive

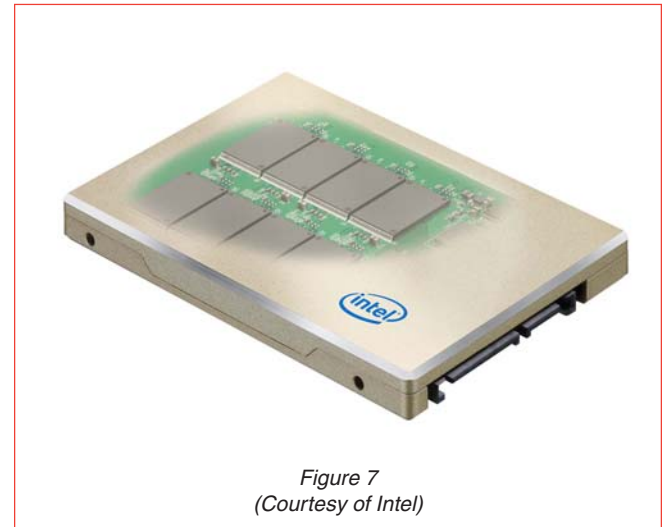

A solid-state drive (SSD) is a data storage device that uses solid-state memory to store data with the intention of providing access in the same manner as a traditional HDD. SSDs are distinguished from traditional HDDs, which are electromechanical devices containing spinning disks and movable read/write heads. Instead, SSDs use microchips which retain data in non-volatile memory chips and contain no moving parts.

Compared to HDDs, SSDs are typically less susceptible to shock and vibration, are silent, have much lower access time and latency, do not display data rate non-linearity, and typically support a limited number of writes over the life of the device. SSDs use the same interface as hard disk drives, thus easily replacing them in most applications.

Most SSDs use NAND-based flash memory, which retains memory even without power. SSDs using volatile random-access memory (RAM) also exist for situations which require even faster access, but do not necessarily need data persistence after power loss, or use external power or batteries to maintain the data after power is removed.

A hybrid drive combines the features of an HDD and an SSD into one unit, containing a large HDD, with a smaller SSD cache to improve performance of frequently accessed files. These are not suitable for data-intensive work, nor do they offer the other advantages of SSDs.

Recording Systems

Client-Server Architecture

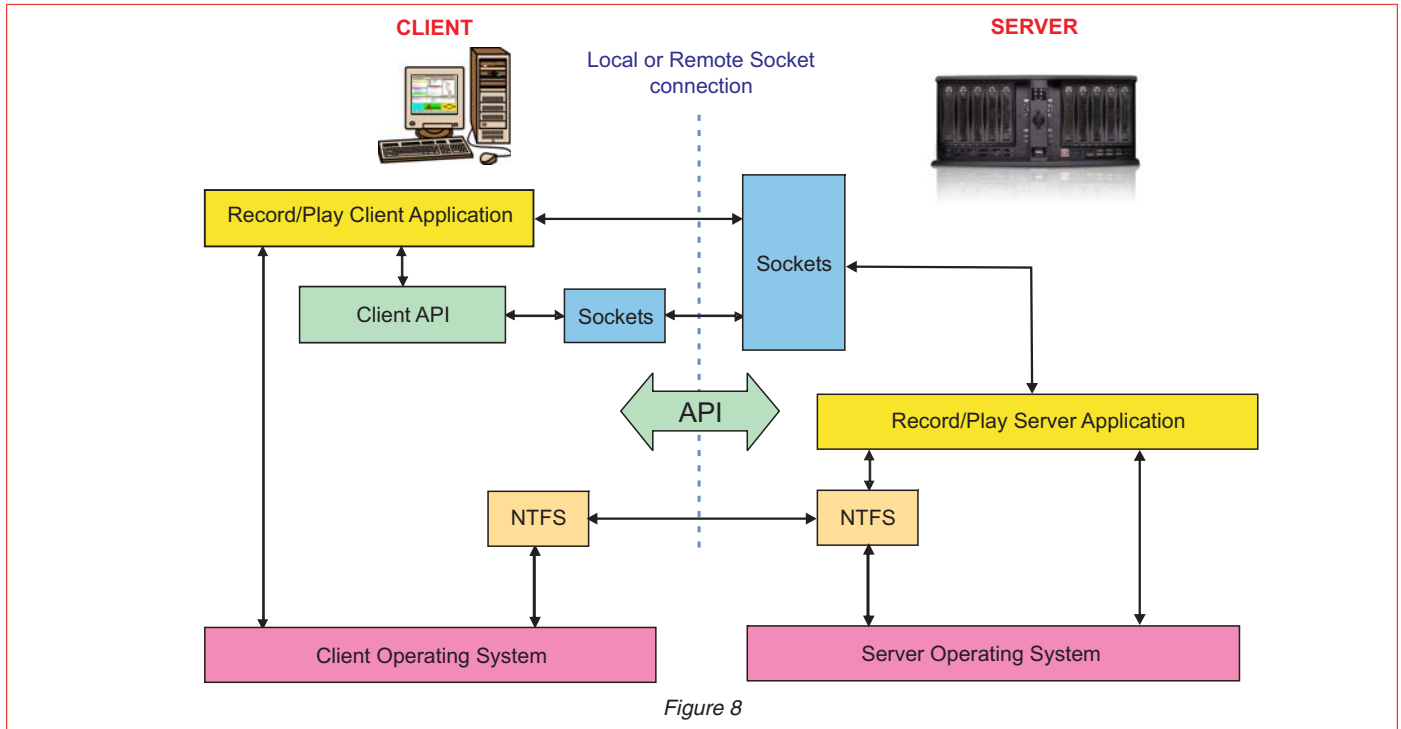

When designing a real-time recorder, it is important to provide the user a control interface that is intuitive and easy to use. The easiest way to achieve this is through a GUI (Graphical User Interface). A GUI enables the user to control the recorder by pushing virtual buttons with a mouse or via a touch screen. The GUI should allow the user to not only control the recorder, but should also provide facilities to manage the data files, utilities to monitor and analyze the signals being recorded, and should provide constant status information to the user.

The GUI should have the ability to run either locally on the recorder or remotely on an independent PC or other device. Being able to run on a remote device allows the user the ability to put the recorder in an environment that may not be appropriate for the operator. This allows the recorder to be close to the sensor or antenna source, placing the A/D or digital I/O interface near the signal of interest.

The best way to provide both local and remote control of the recorder is through a client-server architecture. This architecture provides a socket-based communication link between the client GUI and the server recording application, separating the real-time portion of the recorder (the Server) from the non-real-time portion (the Client). The client can then connect to the server, whether the client sits on the server PC itself or on a PC that is connected to the server over Ethernet.

By sending messages to the server, the client GUI can control all aspects of the recorder. This includes the ability to start and stop recordings, to set up front-end hardware parameters, to monitor incoming signal information and to request status information from the server. The interface for this messaging structure should be defined in an API (Application Programming Interface). While the API is used by the GUI to communicate with the server, it can also be provided to the user in a format that allows the recorder to be integrated into a larger system. ➤

(More on the next page)

Recording Systems

User API

By providing a user API, the recorder becomes more than a stand-alone system, it serves as a user development platform as well. This allows different types of users the flexibility they may desire, while providing the out-of-the-box experience of a system all in one product.

In order to define an API that can be easily integrated into a larger application, it is important to define the API routines in a simple and straightforward manner. These routines should abstract the user from the details of the message building, the socket interface and other intricacies of the recording architecture. Error checking should be included in the recording server, allowing the user to receive error codes in response to failed messages.

The API should not only contain routines that control the interface, but should also contain routines that obtain general status information, perform built-in-test facilities and allow the user to view snapshots of the data prior to and during recording. Combining these facilities provides the user with the ability to create a well-featured recorder application as part of a bigger system.

Other Design Considerations

One of the problems engineers often have to deal with after recording data in the field is the issue of offloading the mission data to a system that will perform the analysis, post-processing and archiving. This process should be made simple and quick, minimizing the down-time that field engineers have during the offload process. There are several strategies to consider here.

The use of a non-proprietary file system, such as NTFS, to record data provides the ability to avoid the offload process required by systems that use a proprietary file system. In this situation, the user can instantly access recordings as standard files on the recording device itself. By providing the disk storage as hot-swappable SATA drives, field engineers can simply swap out disks filled with mission data for fresh ones and transport only the data disks to their analysis system. By adding a RAID controller to the analysis system, similar to the one

designed into the recorder, data can instantly be accessed on the analysis machine, avoiding the offload process completely. Additionally, the recorder is instantly available to collect new data as soon as the disk swap is made, allowing for almost no downtime in the field.

Data files that are provided to the analysis system must contain critical information related to the recording event itself. This can be accomplished by adding a small header to the beginning of each data file. The parameters stored in this header should be well-defined, containing all of the critical information about the recording, including time-stamping, I/O module settings, and general information about the recording session itself. Additionally, user-settable fields should be reserved, allowing the user to add other information to the file header.

The information stored in the file header can be used by system analysis and signal visualization tools. Integrating these tools into the recorder provides a robust product; one that allows field engineers the ability to verify their signal integrity prior to, during, and after a recording session.

Summary

It is important to consider all of the qualities inherent in a high-performance, user friendly system, when creating a real-time recorder. The use of a high-performance PC allows us to take advantage of the latest technology, while the use of a non-proprietary file system provides us with the convenience of immediate access to the data files. A GUI provides an easy-to-use control panel, while the availability of a user API enables the integration of the recorder into a larger system application.

By building this platform on a well-defined client-server architecture, the developer can provide both of these facilities to the user. Integrating this with a high-performance front-end I/O module and the latest technology offered by the PC market assures that the system will provide a satisfying experience with excellent reliability.

Talon™ Recorders

Talon High-Speed Recording Systems: Flexible and Deployable Solutions

Systems Include:

- ❑ High-performance Windows® workstation
- ❑ High-performance Intel® processor
- ❑ Pentek SystemFlow® recording software with graphical user interface
- ❑ SystemFlow virtual oscilloscope and spectrum analyzer
- ❑ Supported RAID levels of 0, 1, 5, 6, 10 and 50
- ❑ Time stamping support
- ❑ Detailed technical documentation

Figure 9

Systems Benefits:

- ❑ Complete turnkey systems
- ❑ Rack-mountable and portable form factors
- ❑ C-callable API for integration into application
- ❑ Sustained recording rates of up to 2 GB/sec
- ❑ Recording to non-proprietary NTFS file system for easy and immediate data access
- ❑ Ideal for communications, radar, wireless, SIGINT, telecom and satcom
- ❑ They are easy to use right out-of-the-box
- ❑ Can be controlled over the Ethernet or the Internet

Figure 10

Talon High-Speed Recording Systems eliminate the time and risk associated with new technology system development. With increasing pressure in both the defense and commercial arenas to get to the market first, today's system engineers are looking for more complete off-the-shelf system offerings.

Out of the box, these systems arrive complete with a full-featured virtual operator control panel ready for immediate data recording and/or playback operation.

Because they consist of modular COTS board-level products and flexible control software, they are easily scalable to larger multichannel data acquisition and recording applications requiring sustained, aggregate recording rates of up to 2 GB/sec.

For example, they can be used as the data acquisition resource for embedded systems in real-time digital signal processing applications. A complete suite of software development tools simplifies custom system integration.

Depending on model, the Pentek offerings are fully integrated systems featuring a range of A/D and D/A resources or digital I/O with high-speed disk arrays.

Since these systems are built on a Windows workstation, users can easily install post-processing and analysis tools to operate on the recorded data.

Pentek systems provide a flexible architecture that can be easily customized to meet user needs. Multiple RAID levels of 0, 1, 5, 6, 10 and 50, provide a choice for the required level of redundancy.

Pentek's High-Speed Recording Systems are available as Lab Systems, Portable Systems and Rugged Systems.

RTS Lab Systems are housed in a 19 in. rack-mountable chassis in a PC server configuration. They are designed for commercial applications in a lab or office environment.

RTS Portable Systems are available in a small briefcase-sized enclosure with an integral LCD display and keyboard. They, too, provide a PC server configuration and are designed for commercial field applications where size and weight is of paramount importance.

RTR Rugged Systems are housed in a 19 in. rack-mountable chassis in a PC server configuration. They are built to survive shock and vibration and they target operation in harsh environments and remote locations that may be unsuitable for humans.



*RTS High-Speed Recording
Systems are designed for
commercial applications.*



*RTR High-Speed Recording
Systems are designed for harsh
environments.*

Talon Recorders

Pentek SystemFlow Architecture

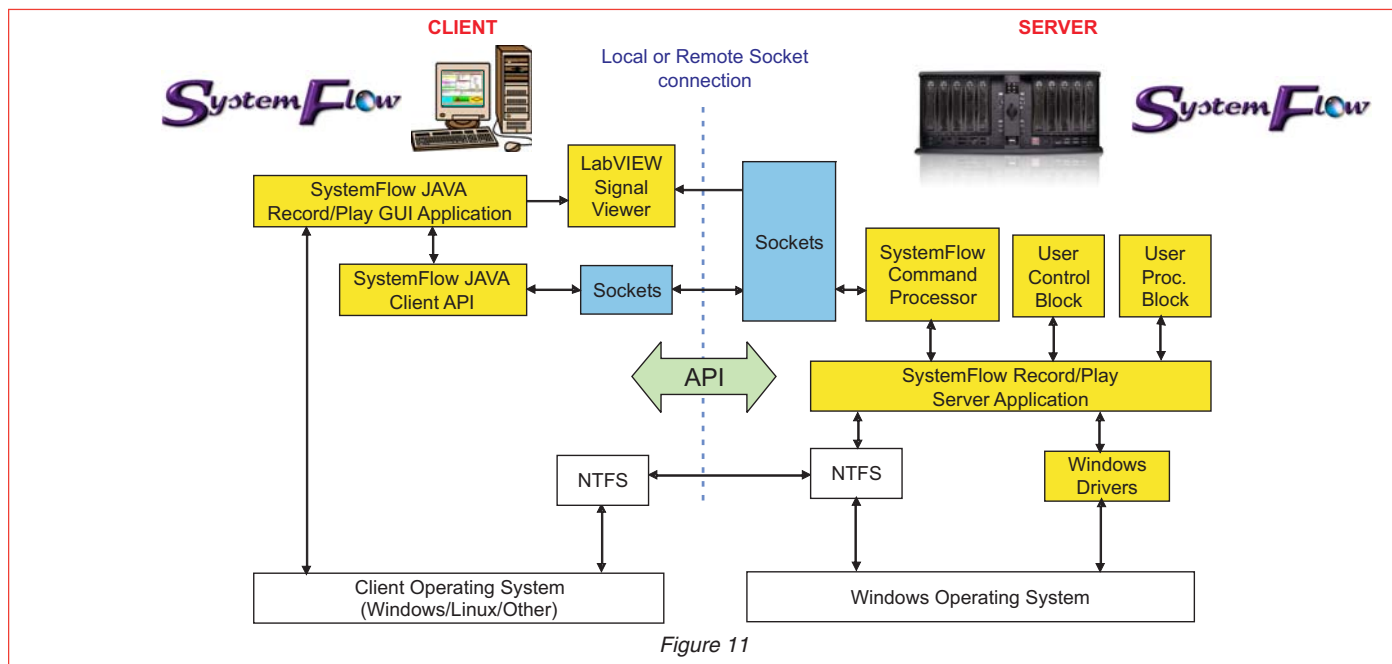

Client/Server Architecture

As shown above, the SystemFlow® architecture provides for easy communication between the recording system Client PC on the left and the Server on the right.

Client/Server Communication

Client and Server communicate through a standard socket connection. This arrangement enables the Server to provide real-time recording and playback functions that can be controlled from a local or a remote Client. It also allows Client and Server to run on different operating systems.

Function Libraries

The function libraries and tools for controlling the recording and playback functions include the Application Programming Interface, the Graphical User Interface and the integrated Signal Viewer.

SystemFlow API

The SystemFlow API allows developers to configure and customize the system interfaces and operation. Source code is supplied for all client API functions. A well-defined set of plugins allows the user to extend server API functions.

SystemFlow GUI

The SystemFlow architecture features a Windows-based GUI that provides a simple means to configure and control the system. Custom configurations can be stored as profiles and later loaded when needed, allowing the user to select preconfigured settings with a single click.

SystemFlow Signal Viewer

SystemFlow also includes signal viewing and analysis tools that allow the user to monitor the signal prior to, during, and after a recording session. These tools include a virtual oscilloscope and a virtual spectrum analyzer. More information on the Signal Viewer is provided on the next page.

NTFS File System

The NTFS file management system provides immediate access to the recorded data, thereby eliminating time-consuming data conversion processes required with proprietary file management systems. It also eliminates the need for custom hardware and software platforms where the recorded data may need to be physically transported for conversion.

Talon Recorders

Pentek SystemFlow Graphical User Interface

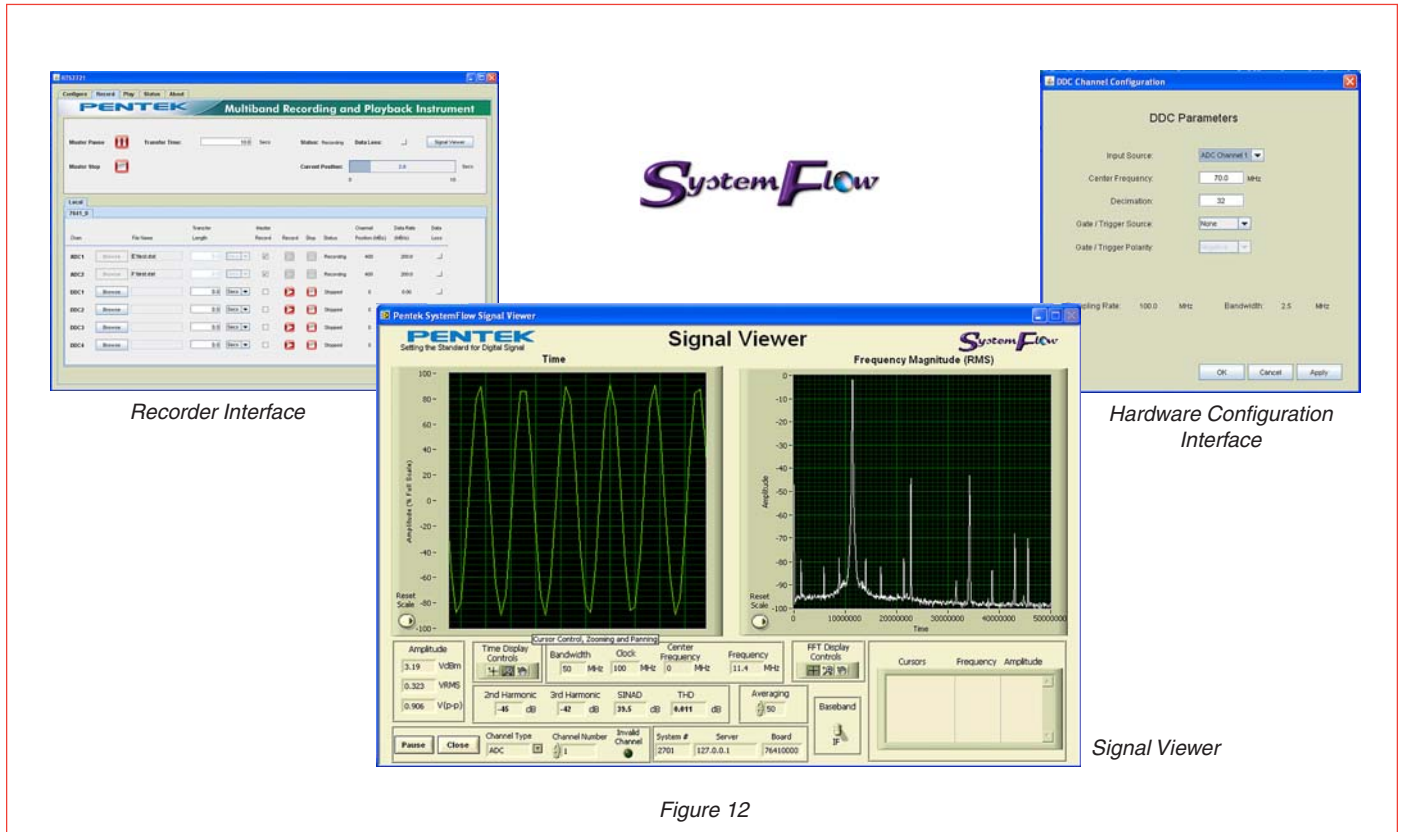

Figure 12

The Pentek SystemFlow recording software provides all the tools for controlling all Pentek high-speed real-time data acquisition and recording systems. SystemFlow software allows developers to configure and customize system interfaces and behavior.

The **Recorder Interface** includes configuration, record, playback and status screens, each with intuitive controls and indicators. The user can easily move between screens to set configuration parameters, control and monitor a recording, play back a recorded signal and monitor board temperatures and voltage levels.

The **Hardware Configuration Interface** provides entries for input source, center frequency, decimation, as well as gate and trigger information. All parameters contain limit-checking and integrated help to provide an easier-to-use, out-of-the-box experience.

The SystemFlow **Signal Viewer** includes a virtual oscilloscope and spectrum analyzer for signal monitoring in both the time and frequency domains. It is extremely useful for previewing live inputs prior to recording, and for monitoring signals as they are being recorded to help ensure successful recording sessions. The viewer can also be used to inspect and analyze the recorded files after the recording is complete.

Advanced signal analysis capabilities include automatic calculators for signal amplitude and frequency, second and third harmonic components, THD (total harmonic distortion) and SINAD (signal to noise and distortion). With time and frequency zoom, panning modes and dual annotated cursors to mark and measure points of interest, the SystemFlow Signal Viewer can often eliminate the need for a separate oscilloscope or spectrum analyzer in the field.

Talon Recorders

Recording Dataflow

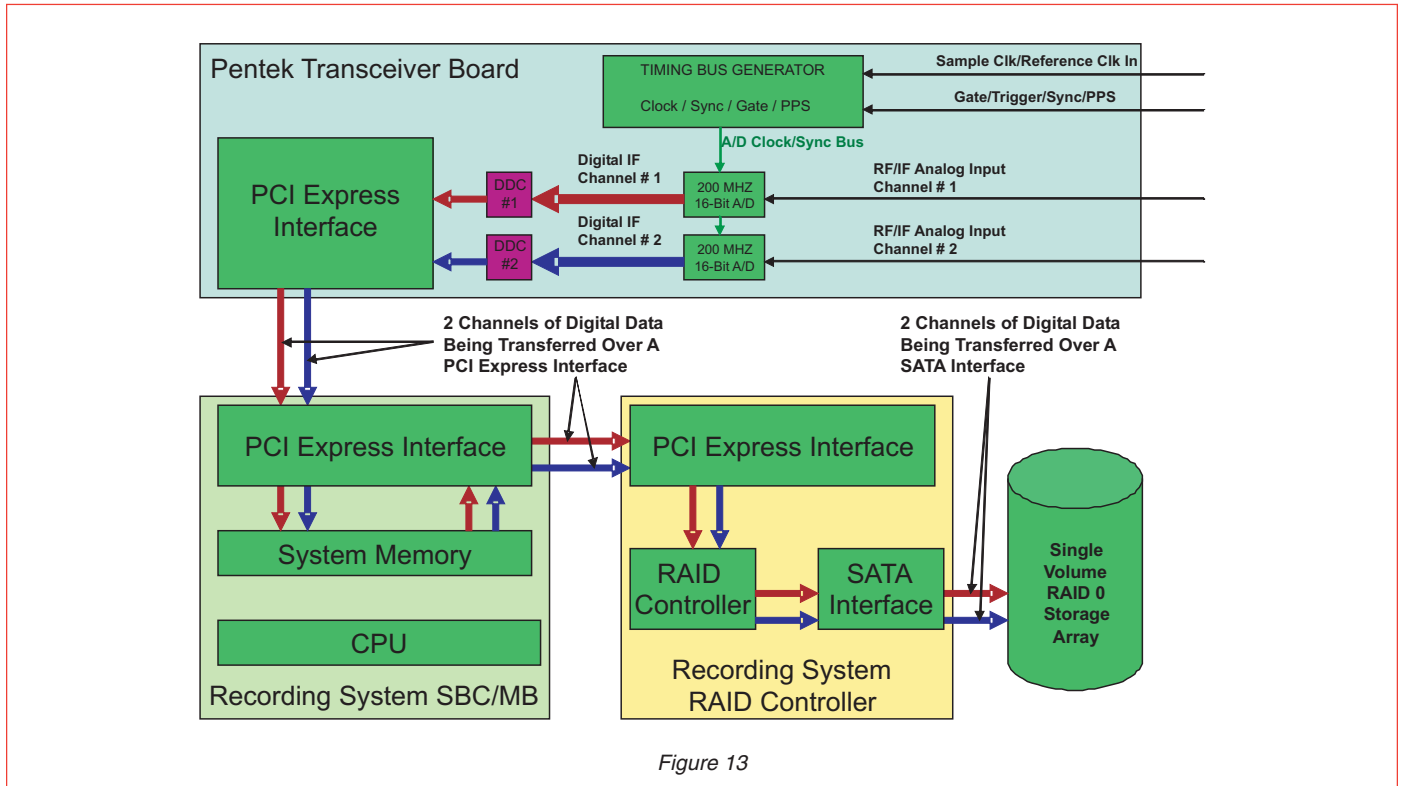

Figure 13

Shown in this diagram is the dataflow during a typical recording session.

The Pentek Transceiver Board contains a 2-channel 200 MHz A/D for digitizing two input analog channels. The digitized outputs are downconverted by the two DDCs (Digital Downconverters) and moved on to the PC system memory via the PCI Express interface. Both

the DDCs and the PCIe interface are implemented in the board's FPGA.

Data then moves from the system memory to the Recording System RAID Controller and is then recorded to disk via the SATA interface. DMA controllers conduct all data transfers, bypassing the CPU for guaranteed real-time operation.

Talon Recorders

Playback Dataflow

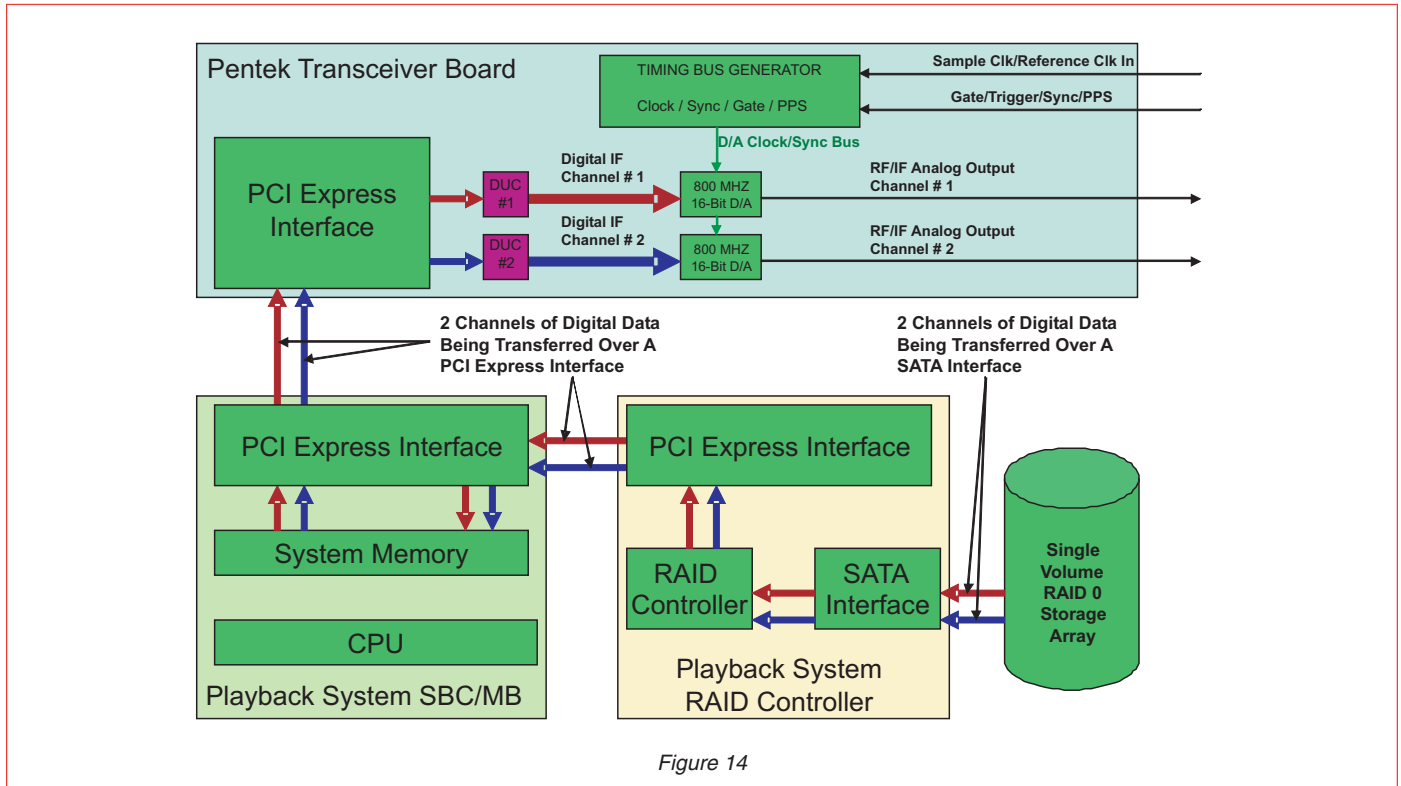

Figure 14

During a playback session, data stored on disk moves through the SATA interface of the Playback System RAID Controller. From there, data is passed to the PC system memory through the PCIe interface and then to the Pentek Transceiver board through its PCIe interface, all via hardware DMA controllers for real-time operation.

This board also contains DUCs (Digital Upconverters) which upconvert the data to the original IF frequency bands. Two 800 MHz D/A's convert the data to analog form and provide signals that are identical to the analog signals that were originally recorded.

These can be further analyzed with any Windows-compatible analysis software.

Talon Recorders

2-Channel RF/IF 125 MS/sec Rack-mount Recorder

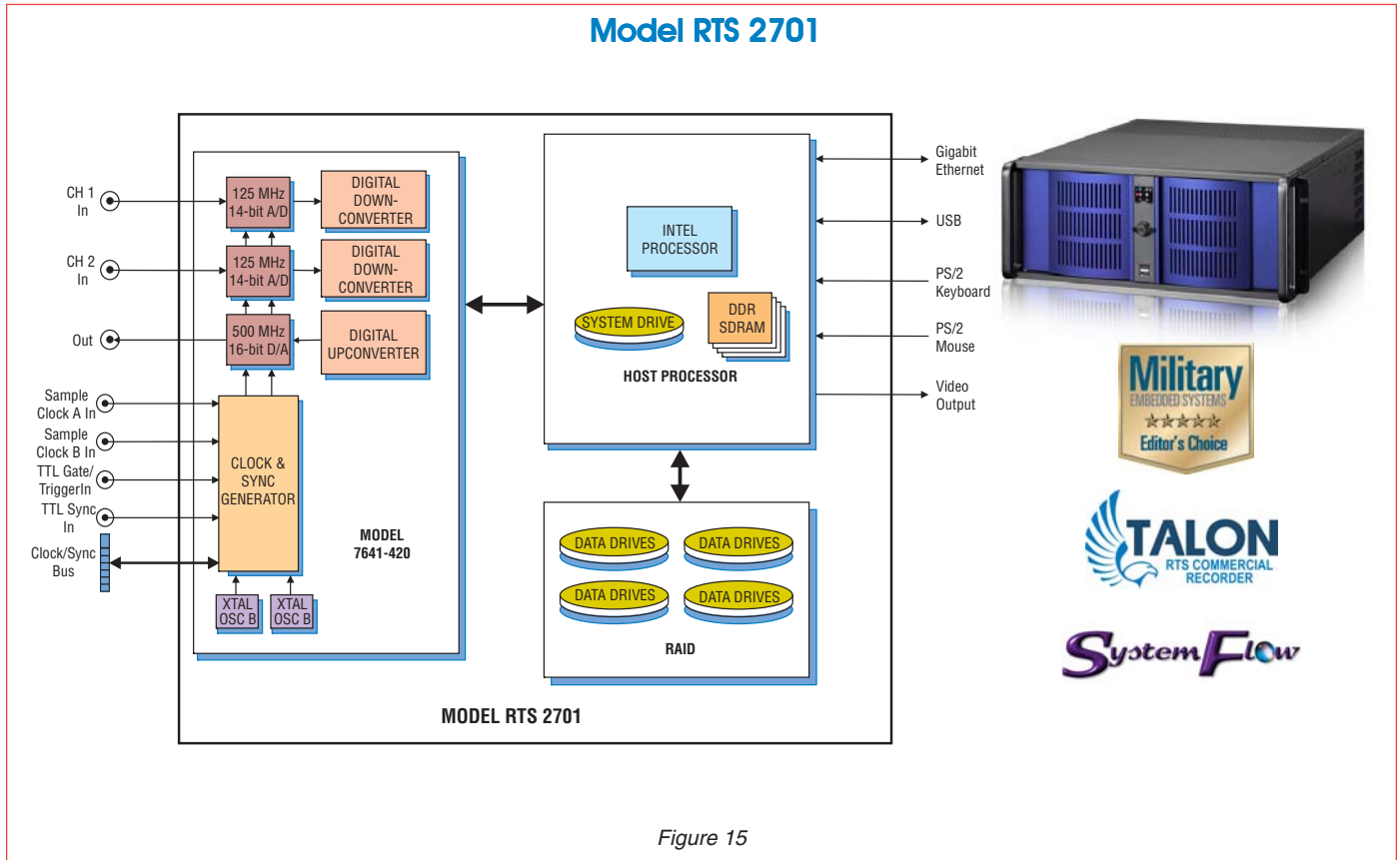

Figure 15

The Talon RTS 2701 is a turnkey, multiband recording and playback system that allows the user to record and reproduce high-bandwidth signals. The RTS 2701 provides sustained recording rates of up to 480 MB/sec in a dual-channel configuration and is ideal for the user that requires a powerful rack-mount recording system.

The heart of the RTS 2701 is the Pentek Model 7641-420 multiband transceiver, which includes A/D and D/A converters, digital upconverters (DUCs), digital downconverters (DDCs), and an FPGA-installed IP core. The architecture allows the system engineer to take full advantage of modern technology in a turnkey system.

Optional GPS time and position stamping allows the user to record this critical signal information.

Included with this system is Pentek's SystemFlow Recording Software. A software API is provided that

allows users to integrate control of this system into their system. Built on a Windows XP Professional workstation, the RTS 2701 allows the user to install post processing and analysis tools to operate on the recorded data. The RTS 2701 records data to the native NTFS file system, providing immediate access to the recorded data. Data can be offloaded via gigabit Ethernet, or USB 2.0 ports. Additionally, data can be copied to disk, using the 8X double layer DVD±R/RW drive.

A high-performance PCI Express SATA RAID controller connects to multiple SATA hard drives to support storage to 4 terabytes and real-time sustained recording rates to 480 MB/sec.

Pentek's multiband recorder system provides a flexible architecture that is easily customized to meet the user's needs. Multiple RAID levels, including 0, 1, 5, 6, 10 and 50, provide a choice for the required level of redundancy.

Talon Recorders

8-Channel RF/IF 200 MS/sec Rack-mount Recorder

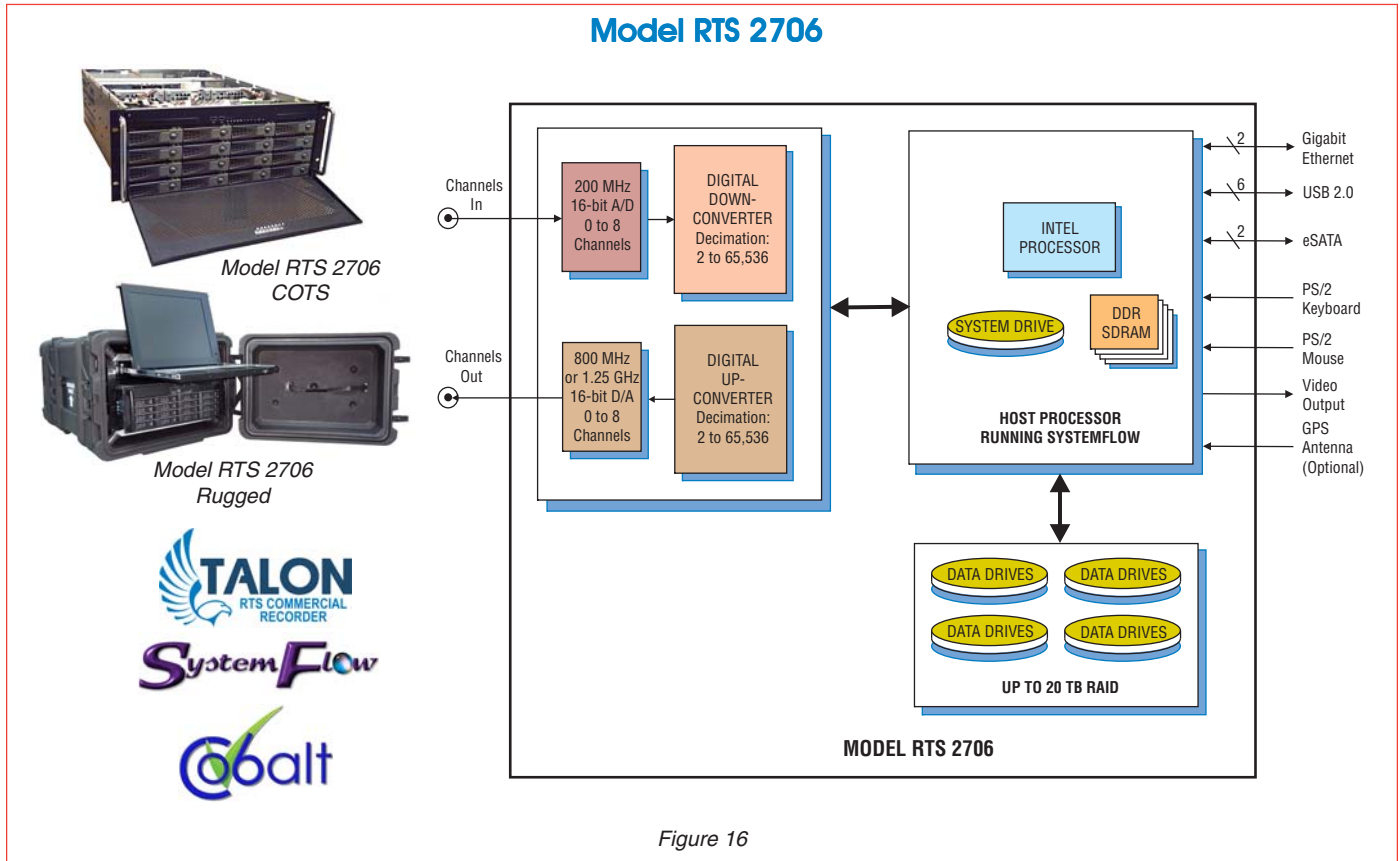

Figure 16

The Talon RTS 2706 is a turnkey, multiband recording and playback system for recording and reproducing high-bandwidth signals. The RTS 2706 uses 16-bit, 200 MHz A/D converters and provides sustained recording rates up to 1600 MB/sec in four-channel configuration.

The RTS 2706 uses Pentek's high-powered Virtex-6-based Cobalt® modules, that provide flexibility in channel count, with optional DDC (Digital Downconversion) capabilities. Optional 16-bit, 800 MHz D/A converters with DUC (Digital Upconversion) allow real-time reproduction of recorded signals.

A/D sampling rates, DDC decimations and bandwidths, D/A sampling rates and DUC interpolations are among the GUI-selectable system parameters, providing a fully-programmable system capable of recording and reproducing a wide range of signals.

Included with this system is Pentek's SystemFlow recording software. Optional GPS time and position stamping allows the user to record this critical signal information.

Built on a Windows 7 Professional workstation with high performance Intel® Core™ i7 processor the RTS 2706 allows the user to install post processing and analysis tools to operate on the recorded data. The system records data to the native NTFS file system, providing immediate access to the recorded data.

The RTS 2706 is configured in a 4U 19" rack-mountable chassis, with hot-swap data drives, front panel USB ports and I/O connectors on the rear panel. Systems are scalable to accommodate multiple chassis to increase channel counts and aggregate data rates. All recorder chassis are connected via Ethernet and can be controlled from a single GUI either locally or from a remote PC.

Talon Recorders

2-Channel 10 Gigabit Ethernet Rack-mount Recorder

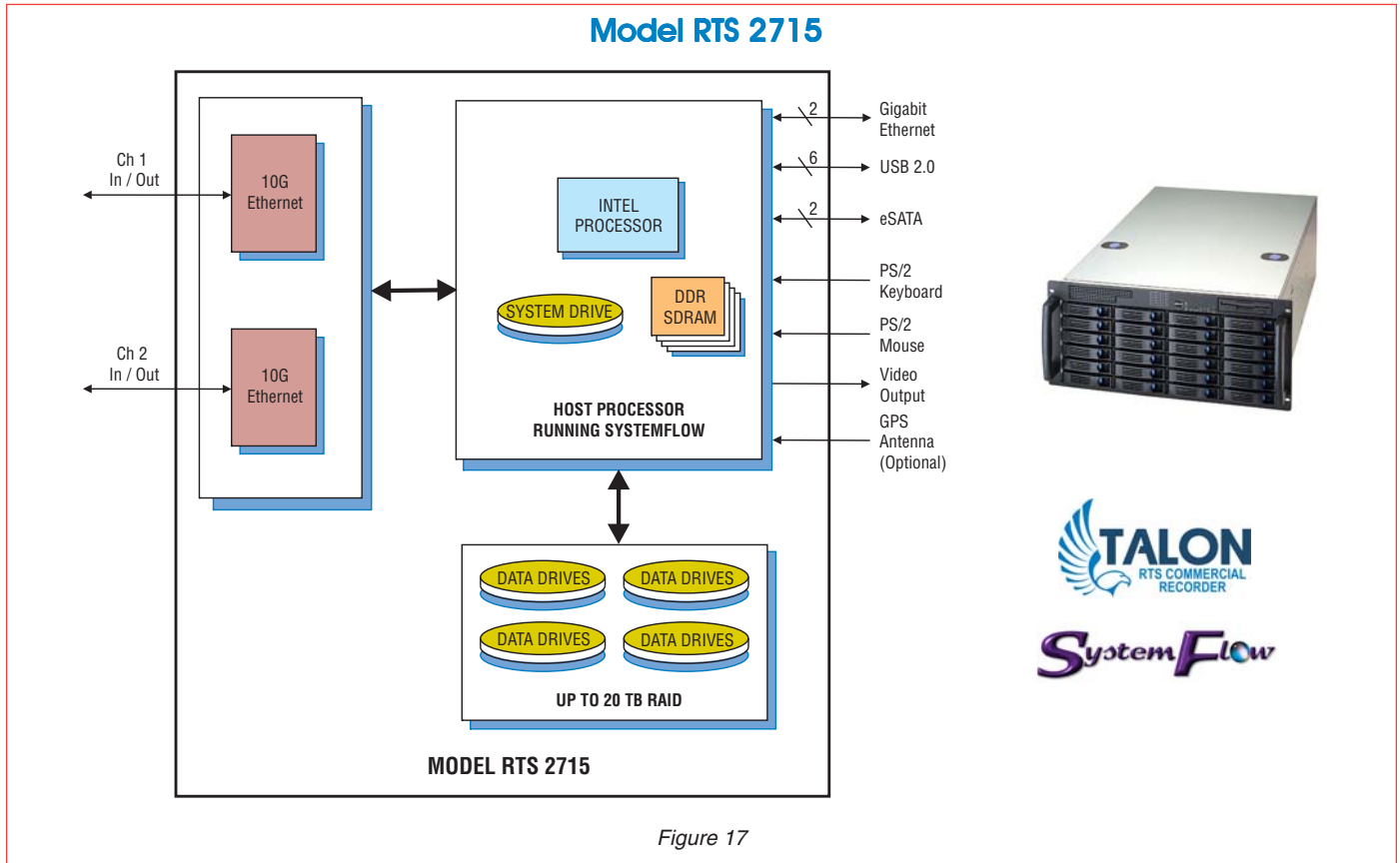

Figure 17

The Talon RTS 2715 is a complete turnkey recording system for storing one or two 10 gigabit Ethernet (10 GbE) streams. It is ideal for capturing any type of streaming sources including live transfers from sensors or data from other computers and supports both TCP and UDP protocols.

Two rear panel SFP+ LC connectors for 850 nm multi-mode or single-mode fibre cables, or CX4 connectors for copper twinax cables accommodate all popular 10 GbE interfaces.

Optional GPS time and position stamping accurately identifies each record in the file header.

The RTS 2715 includes the SystemFlow Recording Software that provides a simple and intuitive means to configure and control the system. Custom configurations can be stored as profiles and later loaded as needed, allowing the user to select preconfigured settings with a single click.

Built on a server-class Windows 7 Professional workstation, the RTS 2715 allows the user to install post-processing and analysis tools to operate on the recorded data. The RTS 2715 records data to the native NTFS file system, providing immediate access to the recorded data.

The RTS 2715 is configured in a 5U 19" rack-mountable chassis, with hot-swap data drives, front panel USB ports and I/O connectors on the rear panel. The 24 hot-swappable HDD's provide a storage capacity of 20 TB.

Systems are scalable to accommodate multiple chassis to increase channel counts and aggregate data rates. All recorder chassis are connected via Ethernet and can be controlled from a single GUI either locally or from a remote PC.

Talon Recorders

2-Channel RF/IF 125 MS/sec Portable Recorder

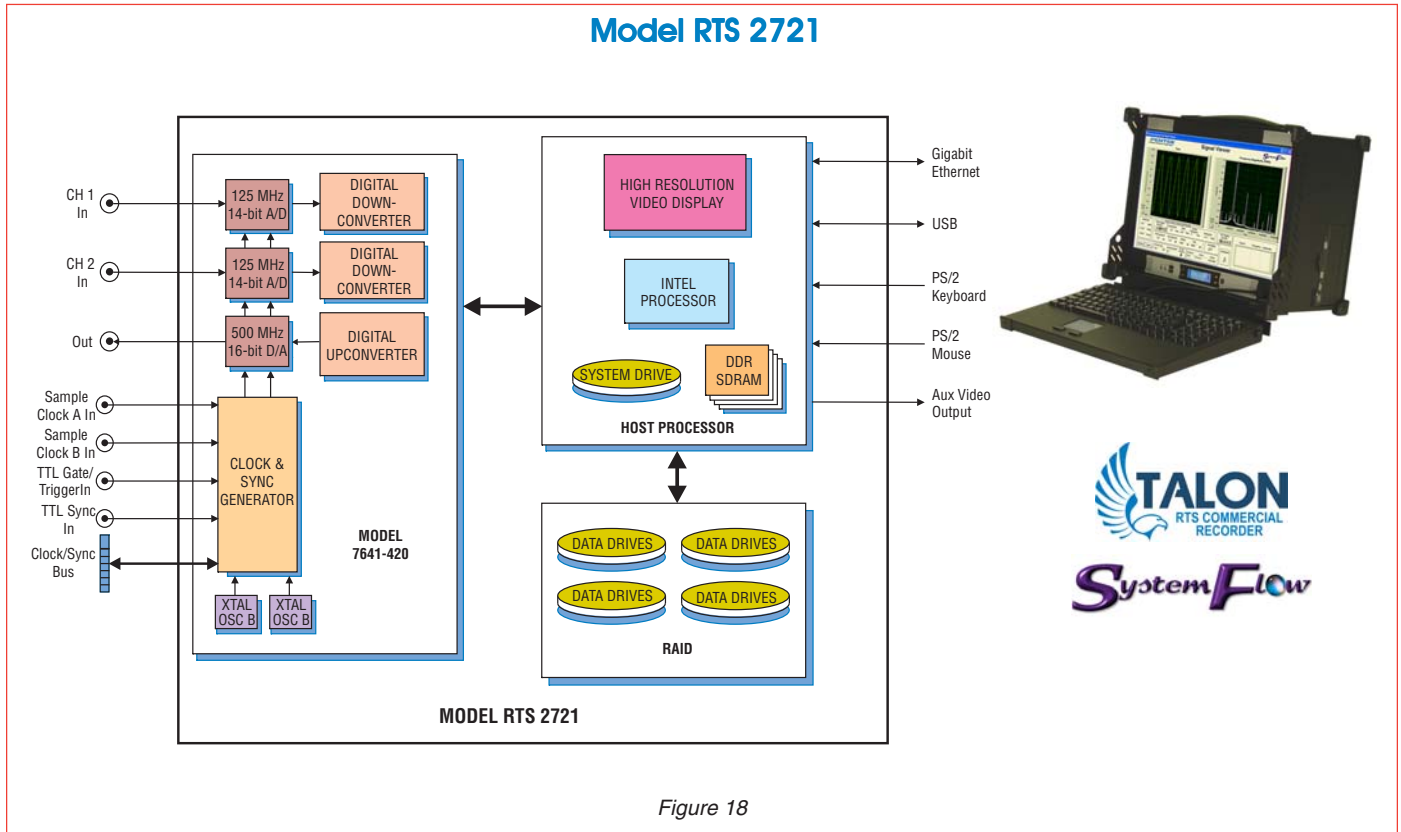

Figure 18

The Talon RTS 2721 is a turnkey real-time recording and playback instrument supplied in a convenient briefcase-size package that weighs just 30 pounds. Built on the Windows XP professional workstation, it includes a dual-core Xeon processor, a high-resolution 17-inch LCD monitor and a high-performance SATA RAID controller.

The RTS 2721 utilizes the Model 7641 multiband transceiver PCI module with two 14-bit 125 MHz A/Ds, ASIC DDC, and DUC with two 16-bit 500 MHz D/As. The factory-installed IP core 420 provides a dual wideband DDC and expands the decimation range of the ASIC DDC. The core also includes an interpolation filter that expands the interpolation factor of the ASIC DUC.

The Model 7641-420 combines downconverter and upconverter functions in one PCI module and offers real-time recording capabilities.

Fully supported by Pentek's SystemFlow recording software, the RTS 2721 uses a native NTFS record/playback file format for easy access by user applications for analysis, signal processing, and waveform generation. File headers include recording parameter settings and time stamping so that the signal viewer correctly formats and annotates the displayed signals.

A high-performance PCI Express SATA RAID controller connects to multiple SATA hard drives to support storage to 3 terabytes and real-time sustained recording rates up to 480 MB/sec.

Pentek's portable recorder instrument provides a flexible architecture that is easily customized to meet special needs. Multiple RAID levels, including 0, 1, 5, 6, 10 and 50, provide a choice for the required level of redundancy. With its wide range of programmable decimation and interpolation, the system supports signal bandwidths from 8 kHz to 60MHz.

Talon Recorders

4-Channel RF/IF 200 MS/sec Rugged Portable Recorder

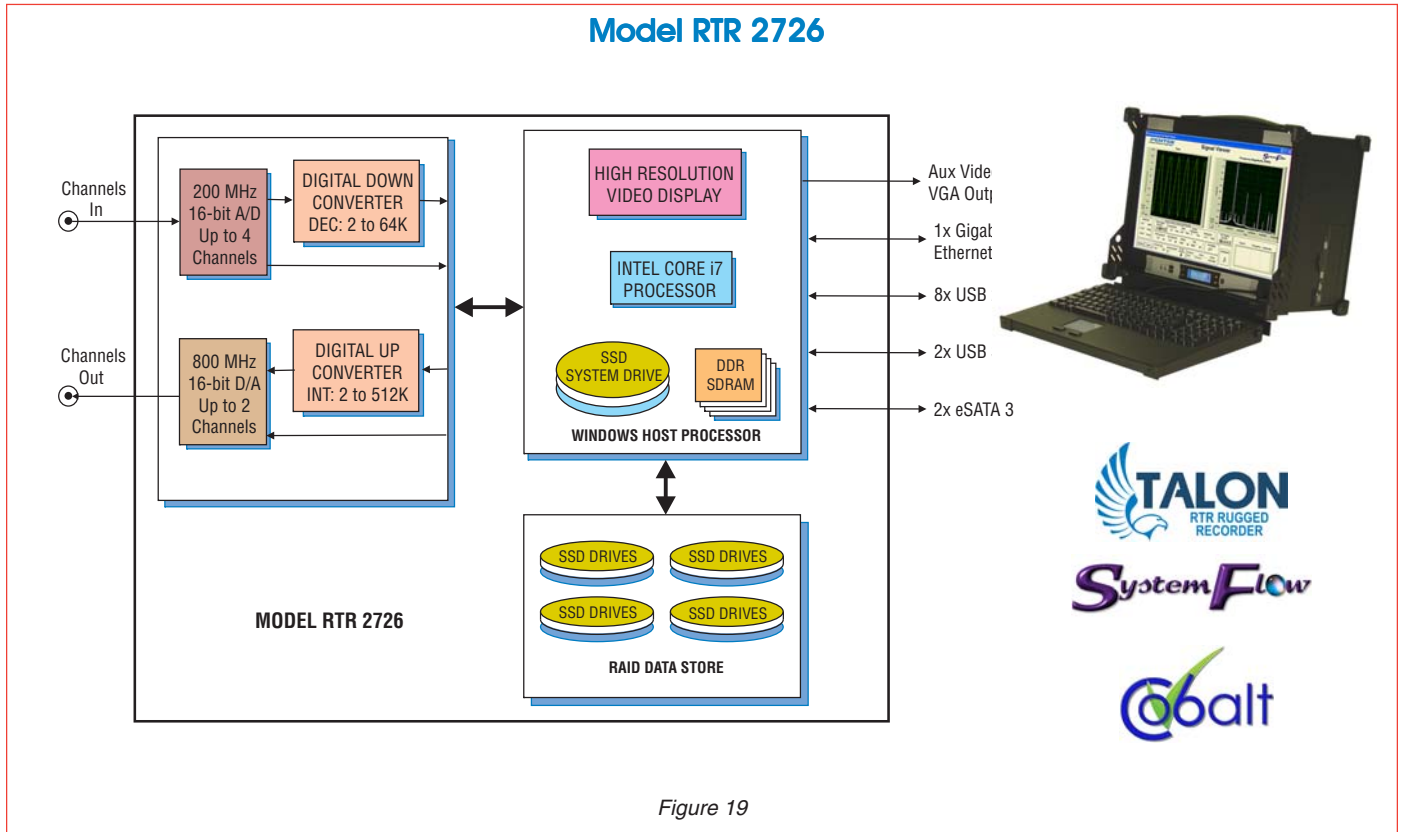

Figure 19

The Talon RTR 2726 is a turnkey, multiband recording and playback system that allows the user to record and reproduce high-bandwidth signals with a lightweight, portable and rugged package. The RTR 2726 provides sustained recording rates of up to 1600 MB/sec in a four-channel system and is ideal for the user who requires both portability and solid performance in a compact recording system.

The RTR 2726 is supplied in a small footprint portable package measuring only 16.9" W x 9.5" D x 13.4" H and weighing just 30 pounds. With measurements similar to a small briefcase, this portable workstation includes an Intel® Core i7 processor a high-resolution 17" LCD monitor, and a high-performance SATA RAID controller.

At the heart of the RTR 2726 are Pentek Cobalt® Series Virtex-6 software radio boards featuring A/D and D/A converters, DDCs (Digital Downconverters),

DUCs (Digital Upconverters), and complementary FPGA IP cores. This architecture allows the system engineer to take full advantage of the latest technology in a turnkey system.

Optional GPS time and position stamping allows the user to record this critical signal information.

Built on a Windows 7 Professional workstation, the RTR 2726 allows the user to install post processing and analysis tools to operate on the recorded data. The RTR 2726 records data to the native NTFS file system, providing immediate access to the recorded data.

Because SSDs operate reliably under conditions of vibration and shock, the RTR 2726 performs well in ground, shipborne and airborne environments. The eight hot-swappable SSD's provide a storage capacity of up to 4 TB. The drives can be easily removed or exchanged during or after a mission to retrieve recorded data.

Talon Recorders

8-Channel RF/IF 200 MS/Sec Rugged Rack-mount Recorder

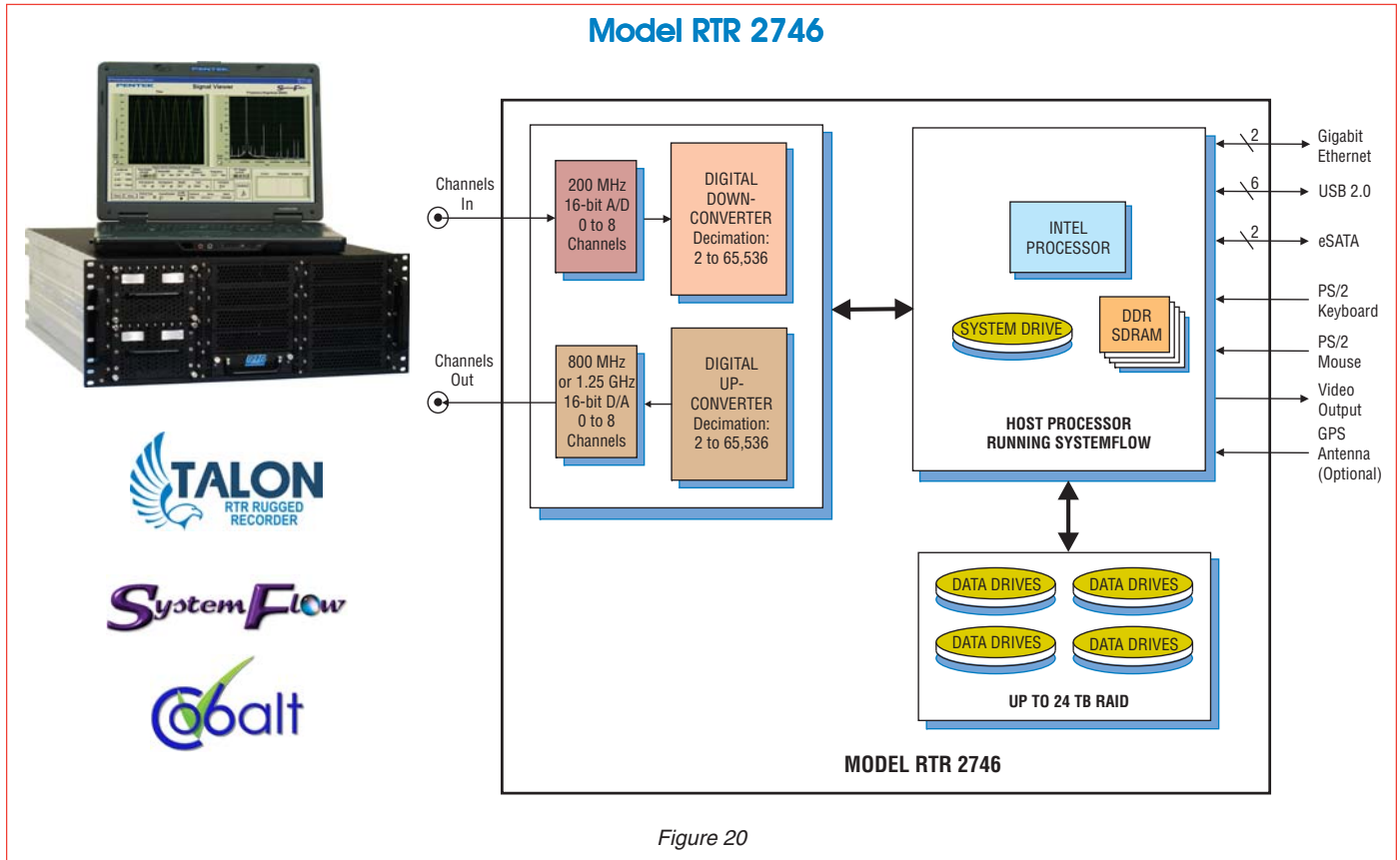

Figure 20

The Talon RTR 2746 is a turnkey, multiband record and playback system that is built to operate under harsh conditions. Designed to withstand high vibration and operating temperatures, the RTR 2746 is intended for military, airborne and UAV applications requiring a rugged system. With scalable A/Ds, D/As and SSD (solid-state drive) storage, the RTR 2746 can be configured to stream data to and from disk at rates as high as 1600 MB/sec.

The RTR 2746 uses Pentek's high-powered Virtex-6-based Cobalt boards, that provide flexibility in channel count with optional digital downconversion capabilities. Optional 16-bit, 800 MHz D/A converters with digital upconversion allow real-time reproduction of recorded signals.

A/D sampling rates, DDC decimations and bandwidths, D/A sampling rates, and DUC interpolations are among the GUI-selectable system parameters, providing a fully programmable system.

The RTR 2746 is delivered in a 4U 19" rugged rack-mountable chassis. Designed to MIL-STD-810F, it is built to survive shock and vibration. Stress to the motherboard and CPU heatsink is mitigated by multiple attachment points to stabilize the PCB. All fasteners and connectors are retained with locking mechanisms and shock-isolated drive bays.

High-speed, high-volume, thermally-controlled fans offer maximum airflow and are designed for long life. Additionally, extended temperature operation is possible with an optional high-temperature CPU.

All recorder chassis are connected via Ethernet and can be controlled from a single GUI either locally or from a remote PC. Multiple RAID levels, including 0, 1, 5, 6, 10 and 50, provide a choice for the required level of redundancy. Up to 48 removable SATA SSD drives are available, allowing up to 24 terabytes of real-time data storage space in a single 4U chassis.

Talon Recorders

2-Channel 10 Gigabit Ethernet Rugged Rack-mount Recorder

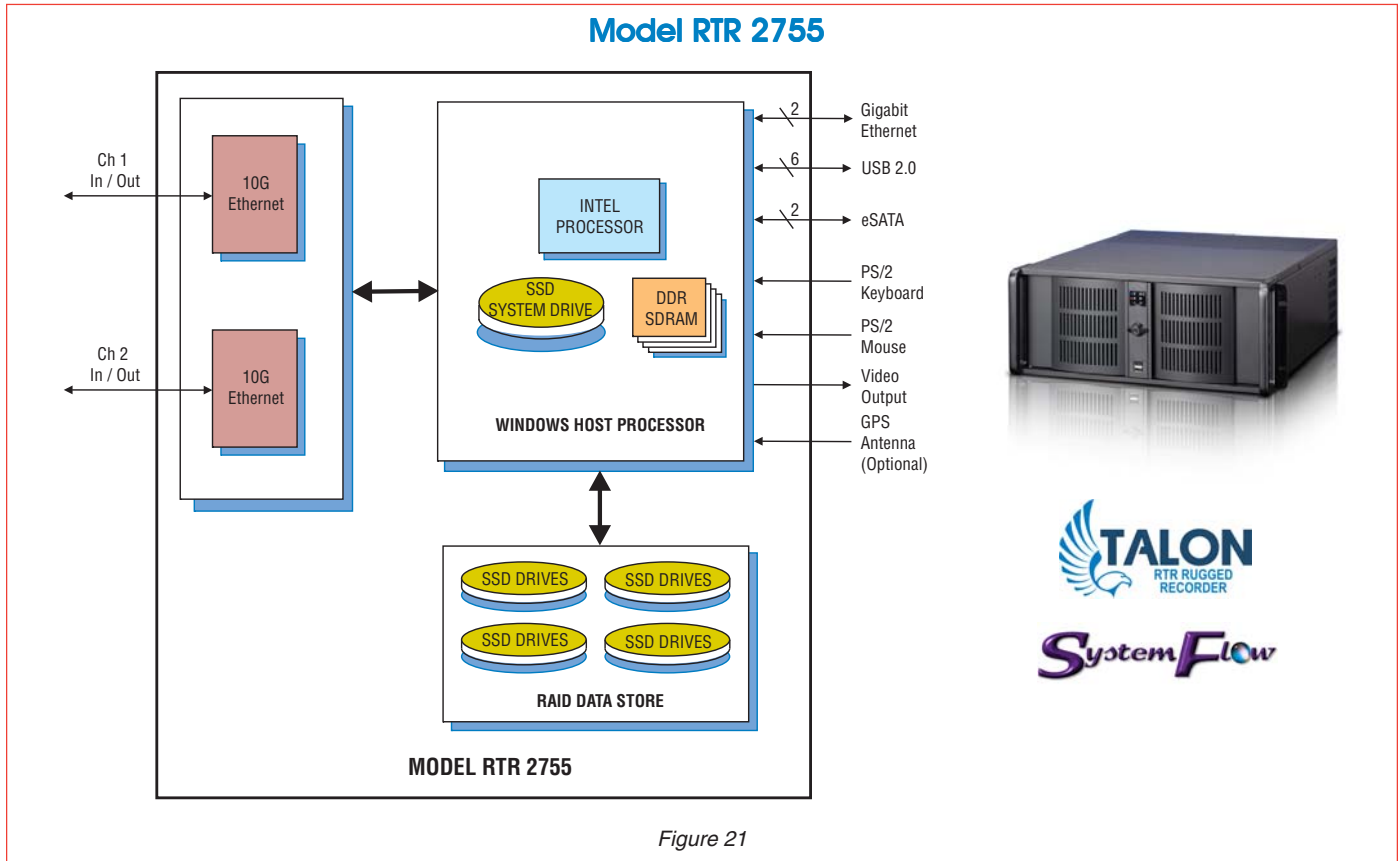

The Talon RTR 2755 is a complete turnkey recording system for storing one or two 10 gigabit Ethernet (10 GbE) streams. It is ideal for capturing any type of streaming sources including live transfers from sensors or data from other computers and supports both TCP and UDP protocols.

Using highly-optimized solid-state drive storage technology, the system guarantees loss-free performance at aggregate recording rates up to 2 GB/sec.

Two rear panel SFP+ LC connectors for 850 nm multi-mode or single-mode fibre cables, or CX4 connectors for copper twinax cables accommodate all popular 10 GbE interfaces.

Optional GPS time and position stamping accurately identifies each record in the file header.

The RTR 2755 includes the SystemFlow Recording Software that provides a simple and intuitive means to

configure and control the system. Custom configurations can be stored as profiles and later loaded as needed, allowing the user to select preconfigured settings with a single click.

Built on a server-class Windows 7 Professional workstation, the RTR 2755 allows the user to install post-processing and analysis tools to operate on the recorded data. The RTR 2755 records data to the native NTFS file system, providing immediate access to the recorded data.

Because SSDs operate reliably under conditions of vibration and shock, the RTR 2755 performs well in ground, shipborne and airborne environments. The twelve hot-swappable SSD's provide a storage capacity of up to 3 TB. The drives can be easily removed or exchanged during or after a mission to retrieve recorded data.

Application

3-Channel Phase-Synchronous Scanning and Recording System

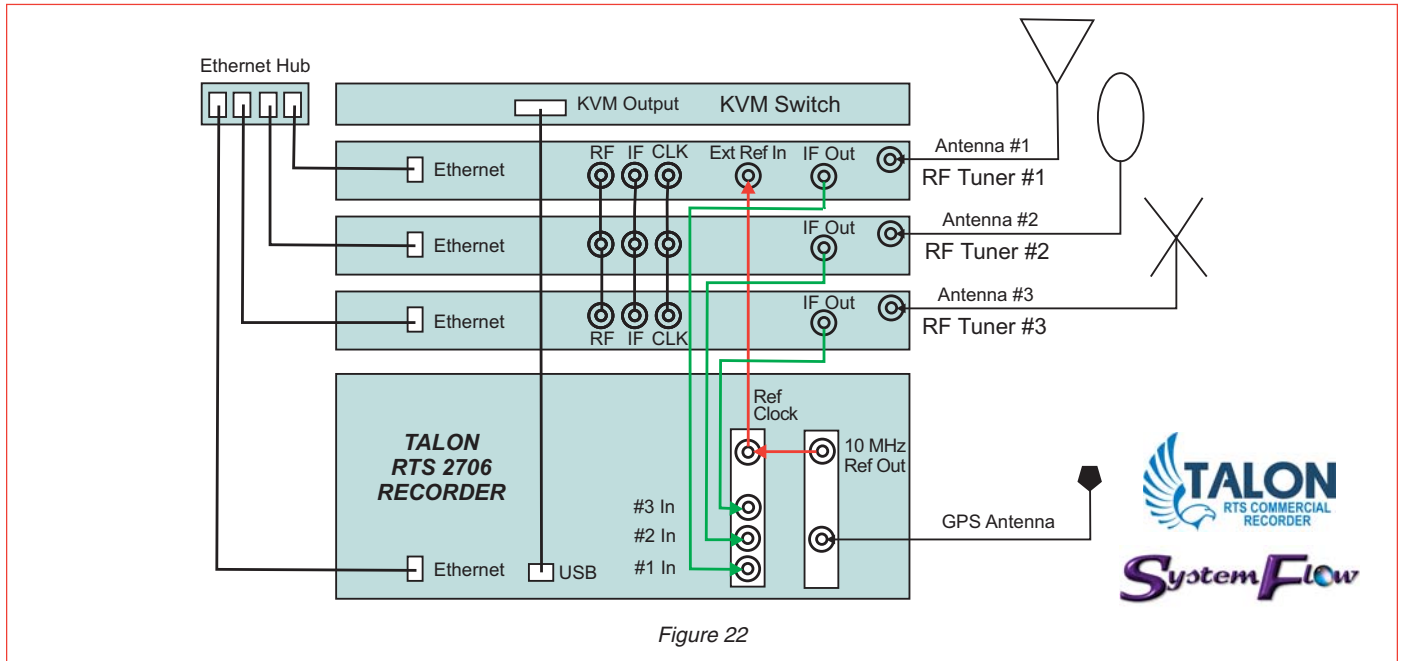

Utilizing the Talon RTS 2706 Configurable Recording System discussed previously, this system provides the ability to scan three RF channels synchronously and record the digitized signals to disk.

In addition to the RTS 2706, this system includes three commercially available rack-mount RF tuners and a KVM switch. An Ethernet hub is included to allow the RTS 2706 to control the tuners through their Ethernet interface. Each tuner's RJ45 Ethernet port is wired to the Ethernet hub which, in turn, is wired to one of the Ethernet ports of the RTS 2706.

The KVM switch is wired directly to one of the USB ports of the RTS 2706. This connection allows for the RTS 2706 to be controlled from a keyboard and mouse attached to the KVM switch. An LCD display can also be attached to this switch for viewing the signals before, during and after the recording.

The three RF tuners are set up to have their IF outputs connected to the three input channels of the RTS 2706 recorder. The recorder is equipped with the Cobalt Model 78621 PCIe 3-Channel 200 MHz A/D with factory-installed 3-Channel DDC in the Virtex-6 FPGA. The DDCs offer a decimation range of 2x to 65,536x providing a wide range to satisfy most applications.

The 10 MHz reference clock is distributed to the A/Ds of the 78621 and also to RF Tuner #1 which, in turn, supplies it to RF Tuners #2 and #3. In addition, the RF LO and the IF LO are distributed from RF Tuner #1 to the others. This arrangement achieves phase-synchronous scanning to meet the specification of this application.

The 10 MHz reference clock is generated by the GPS board which is located in one of the PCIe slots of the RTS 2706 recorder. A GPS antenna is supplied with the system and provides for accurate position and time-stamping of each recording. ➤

Application

3-Channel Phase-Synchronous Scanning and Recording System

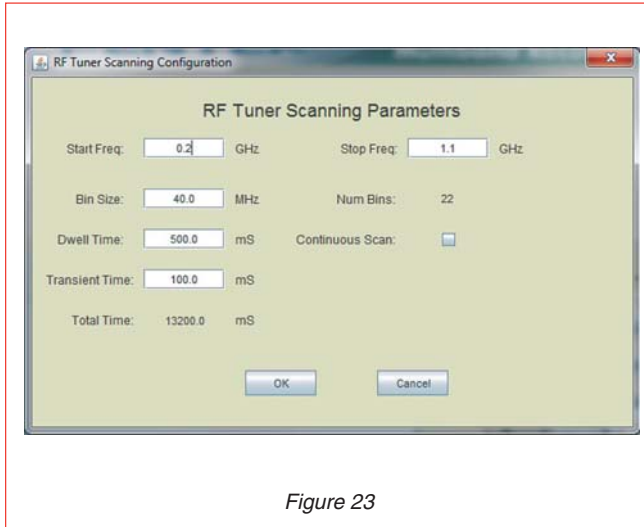

Figure 23

The Pentek SystemFlow recording software supplied with this system provides all the features discussed previously. In addition, controls for a scanning facility are included. The screen shot shown here allows the user to define the start and stop frequencies of the scan, the frequency bin size, dwell time, and other scan parameters that may be important to a particular scan.

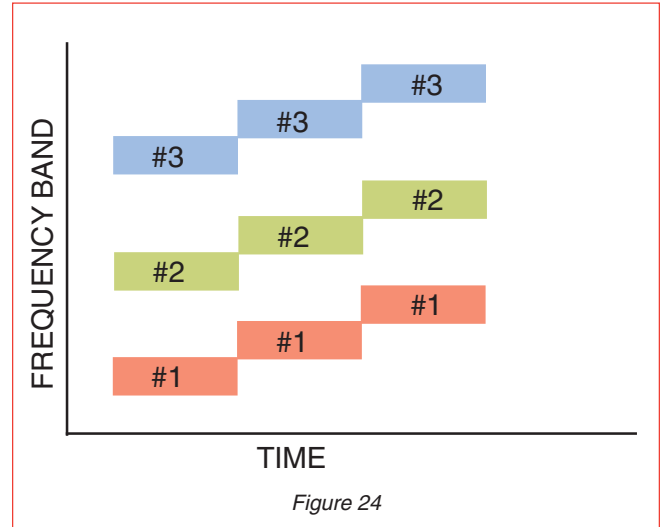

Figure 24

A typical example of a three-channel phase-synchronous scan is shown above.

This system has been successfully built, tested and delivered by Pentek as Model RTS 2706-013.

Appendix A: High-Speed A/D Converters

High Speed A/D Converter Markets

- Commercial Wireless
- Military Communications
- Radar
- Sonar
- Telemetry
- Beamforming
- Direction Finding
- Wireless Networks
- Control Systems
- Signals Intelligence
- Medical Imaging
- Military Countermeasures
- Nuclear Instrumentation
- Structural Analysis

Figure 25

Markets for high-speed A/D converters are significant in size and many are growing rapidly. New markets emerge regularly based on A/D technology advances, lower costs, and the general trend of replacing older mechanical and analog systems with DSP (digital signal processing) systems.

DSP offers significant advantages for handling signal complexity, communications security, improved accuracy and reliability, reduced size, weight and power.

Commercial users of high-speed A/Ds include wireless mobile communication systems, airline radar systems, air traffic control towers, ship communications, and wireless networks for home, office and public facilities.

Industrial uses include medical imaging systems and process control systems for manufacturing.

Government systems account for many of the high-end applications such as phased-array military radar, communications countermeasure systems, global military radio networks, unmanned aerial vehicles and intelligence gathering systems.

New Monolithic A/D Technology

- Smaller geometry, lower core voltages and power dissipation
- Much higher sample rates and bit accuracy
- Wideband input circuitry optimized for direct IF sampling
 - IF (intermediate frequency) signals are usually greater than Fs
 - Differential, transformer coupled inputs minimize noise
- High Performance Integrated S&H (sample-and-hold)
 - Higher immunity to clock waveform symmetry and level
- Improved multi-stage flash conversion techniques
- Digital sample code generation and error correction
 - Devices can be calibrated and trimmed during production
- Improved thermal tracking of DC offset, gain, and linearity
- Improved power supply noise rejection and immunity

Figure 26

Because of the complexity of these market segments, wideband A/D converters have made significant advances in recent years.

This is due partly to silicon process improvements and also to many applications that require direct sampling of IF signals well above 100 MHz.

One of the most important advances is the sample-and-hold (or track-and-hold) circuitry at the front end.

Just as important, are new sample clock interfaces and drivers.

At these speeds, you need state-of-the-art flash and multistage flash conversion techniques.

New techniques in digital error code correction and thermal compensation circuitry help eliminate errors in bit accuracy, linearity and gain.

Lastly, these new devices are more immune to power supply and system noise.

Appendix A: High-Speed A/D Converters

Monolithic A/Ds for $F_s > 100$ MHz, bits ≥ 8

| Monolithic A/D Converters | | | | | |
|---------------------------|------------|--------------|----------|------|-----------|
| Manufacturer | Part No. | Sample Freq. | Channels | Bits | Input BW |
| Ti-National | ADC12D1800 | 3,600 MHz | 1 | 12 | 1,750 MHz |
| Linear Tech. | LTC2380-16 | 2,000 MHz | 1 | 16 | 34 MHz |
| e2v | AT84AS008 | 2,000 MHz | 1 | 10 | 3,000 MHz |
| Ti-National | ADC12D1800 | 1,800 MHz | 2 | 12 | 2,800 MHz |
| Linear Tech. | LTC2379-18 | 1,600 MHz | 1 | 18 | 34 MHz |
| Maxim | MAX108 | 1,500 MHz | 1 | 8 | 2,200 MHz |
| Ti-National | ADC08D1000 | 1,000 MHz | 2 | 8 | 1,700 MHz |
| e2v | AT84AD001B | 1,000 MHz | 2 | 8 | 1,500 MHz |
| Maxim | MAX101A | 500 MHz | 1 | 8 | 1,200 MHz |
| e2v | AT84AD004 | 500 MHz | 2 | 8 | 1,000 MHz |
| Texas Instr. | ADS5463 | 500 MHz | 1 | 12 | 750 MHz |
| Texas Instr. | ADS5474 | 400 MHz | 1 | 14 | 750 MHz |
| Texas Instr. | ADS5485 | 200 MHz | 1 | 16 | 300 MHz |
| Analog Dev. | AD9480 | 250 MHz | 1 | 8 | 400 MHz |
| Analog Dev. | AD9430 | 215 MHz | 1 | 12 | 700 MHz |
| Analog Dev. | AD9410 | 210 MHz | 1 | 10 | 500 MHz |
| Analog Dev. | AD9054 | 200 MHz | 1 | 8 | 350 MHz |
| Linear Tech. | LTC2255 | 125 MHz | 1 | 14 | 300 MHz |

Figure 27

Shown in the table above are some representative examples of commercially available, monolithic A/D converters with sampling rates greater than 100 MHz and resolution of at least 8 bits.

All these devices are potential candidates for board-level products for embedded systems, such as those made by Pentek.

Many of them are indeed used in current Pentek board-level A/D converter and software radio products; some of them are also used in Pentek recording systems,

We have listed the input bandwidth in this table to highlight the importance of these A/Ds in direct IF sampling applications, also known as undersampling.

In the next section, we'll discuss in some detail the principles and rules of sampling.

Appendix A: High-Speed A/D Converters

Direct Baseband RF Signal Acquisition

- Antenna signals are usually in the microvolt range
- RF amplifier boosts signal to full scale input voltage of the A/D - usually 0 to +10 dBm
- RF amplifier often includes a tuned bandpass filter centered on the signal of interest
- No analog frequency translation before the A/D
- Appropriate for HF signal frequencies (3 - 30 MHz)

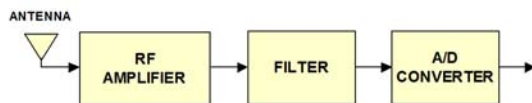

Figure 28

Most receiver systems start with a signal originating from an antenna that's often in the microvolt level, so it must first be amplified by an RF amplifier stage.

The amplifier is usually a tuned RF circuit which only passes the frequency band of interest, providing signal gain within that band and rejecting noise and unwanted signals in adjacent frequency bands.

If the RF input signal is at a low enough frequency, it can be digitized directly by an A/D converter, and no analog translation is necessary.

For example, you can usually perform direct baseband sampling on HF signals with no translation required, since the frequency content is below 30 MHz.

Analog RF Frequency Translation

▪ Analog Translation to Baseband

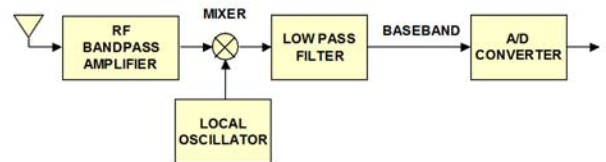

▪ Analog Translation to IF (Intermediate Frequency)

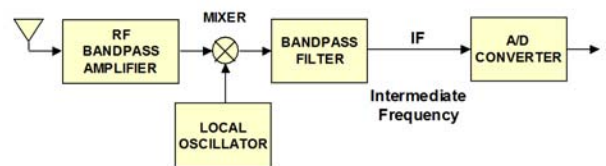

Figure 29

In the case where the antenna signal frequency is too high to be digitized directly by the A/D converter, it has to be translated down using an analog mixer and local oscillator.

The top diagram shows a simplified representation of this analog translation to baseband with a low pass filter following the mixer.

The bottom diagram shows the translation to an intermediate frequency or IF — this is quite common. In this case, the filter is a bandpass filter centered at the IF frequency.

So far, we've discussed three types of front end circuitry:

- 1) Direct sampling with no translation
- 2) Analog translation to baseband
- 3) Analog translation to IF

But how do we design the filters in each case?

Let's go back to review some fundamental sampling theory.

Appendix A: High-Speed A/D Converters

Filtering Helps Avoid Noise and Aliasing

- In all systems, the A/D input must be filtered for two important reasons:
 - Eliminate out of band noise
 - Eliminate aliasing
- Nyquist sampling theorem requires the input signal bandwidth must be less than one-half the sampling rate of the A/D converter
- Some systems (like an IF stage) provide inherent bandlimiting before the A/D
- Fundamental Sampling Modes
 - Baseband Wideband Sampling
 - Baseband Pre-select Sampling
 - Undersampling

Figure 30

Filters ahead of the A/D are needed primarily for two reasons: to eliminate out-of-band noise and to eliminate out-of-band signals that can cause aliasing.

Nyquist tells us that whenever you sample a signal with an A/D, the bandwidth of that signal must be less than half the sampling frequency of the A/D.

Filters help us guarantee that this rule is met. Sometimes the bandwidth is already limited by the signal source, like the output of an IF stage that takes advantage of the IF filter bandwidth. But each case has to be analyzed individually.

The design of the filter is also critically linked to the sampling mode. Here we've listed three fundamental sampling modes:

- 1) Baseband **wideband** sampling
- 2) Baseband **preselect** sampling
- 3) **Undersampling**, which is also sometimes called subsampling

To help you get a feel for the filter requirements of each mode, we present a convenient tool for analyzing the effects of sampling in the frequency domain.

Fan-fold Paper Model to Visualize Sampling

- Plot the spectrum of the input signal on transparent fan-fold printer paper scaled so the frequency axis is aligned with multiples of F_s on the backward folds

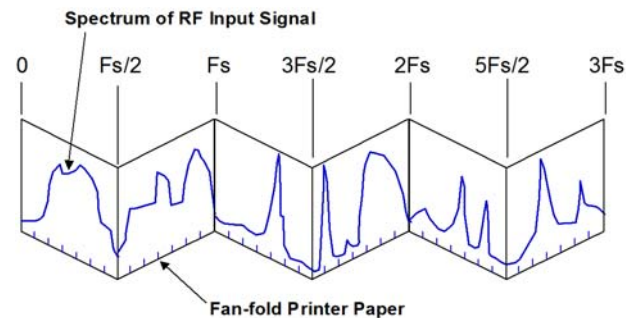

Figure 31

This simple technique has been very useful to our customers and our own applications engineers to help them understand what happens during sampling.

Imagine that we have a stack of the old fan-fold computer printer paper but with transparent sheets.

Now, we assign the frequency axis along the bottom edge of this paper, scaled so that multiples of the sampling frequency line up with the backward folds of the paper, as shown.

Using that frequency scale, we plot out the spectrum of the signal we want to sample with amplitude plotted on the vertical axis.

High-Speed A/D Converters

Fan-fold Paper Model to Visualize Sampling

- Now collapse the stack of transparent fan-fold paper and look through all the sheets
- This represents how sampling “folds” the entire RF input spectrum into a single page from 0 to $F_s/2$
- Once aliasing occurs, there is no way to undo it

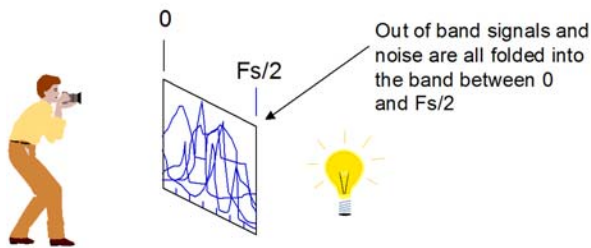

Figure 32

Now, let's collapse the stack of transparent paper flat together and hold the stack up to a light so we can see through all the sheets.

We are now looking at the frequency plot of the sampled signal at the output of the A/D converter.

Notice that we've lost a lot of information because we can't tell which sheet a particular signal is on. And, unfortunately, after sampling that information is lost forever.

We've also contaminated any particular signal with signals from other sheets which have folded on top of it.

Not only that, we've also folded the noise from all the sheets so they pile up in the region between DC and the half sampling rate, potentially ruining the signal to noise ratio.

How do we avoid this mess in each of the three sampling modes?

Baseband Sampling of Wideband Signals

- For baseband signals over a wide frequency range, use a low pass filter with cutoff frequency, F_c , less than $F_s/2$, where F_s is the A/D sample rate
- After sampling, only the baseband signal is captured, eliminating folding of aliased signals and noise

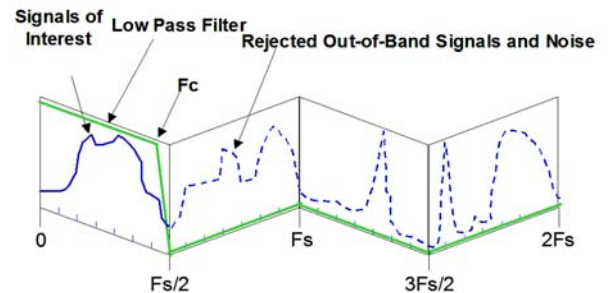

Figure 33

For the baseband **wideband** sampling mode, where we want to look at everything from DC up to a frequency below the half sampling rate, we can install a low pass filter with a cutoff frequency, F_c , located below $F_s/2$.

The frequency response of the filter is shown in green.

Now, all of the out-of-band signals and noise on the pages above $F_s/2$ are eliminated so that when the folding occurs, it doesn't corrupt the baseband signal.

Appendix A: High-Speed A/D Converters

Baseband Sampling of Preselect Signals

- For narrowband signals at baseband, using a pre-select bandpass filter can optimize the dynamic range of the A/D converter by rejecting strong adjacent signals and out-of-band signals and noise
- Pre-select filter is a bandpass filter whose passband is centered on the signal of interest

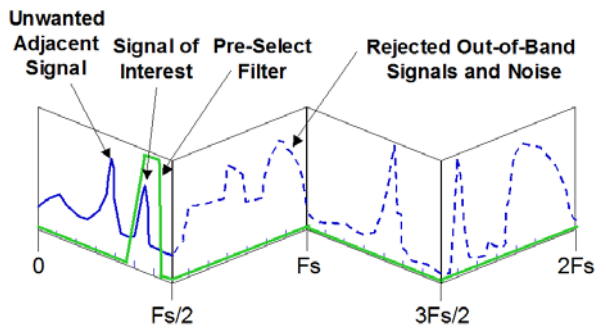

Figure 34

For the baseband preselect sampling mode, we need to use a bandpass filter with the frequency response shown in green.

We get the same benefits as the previous case for out-of-band signals and noise above $F_s/2$, but more importantly, we can keep large adjacent signals like the one shown, from getting to the A/D converter.

The reason for this is that if the large unwanted signal gets through to the A/D converter, it uses up its dynamic range.

For applications where there are known, strong unwanted signals, this technique can be extremely useful in improving the signal-to-noise ratio of the smaller signal of interest.

Principles of Undersampling

- For narrowband signals above $F_s/2$, undersampling can be used to intentionally “alias” the input signal
- Very useful for IF outputs of UHF/VHF receivers
- Successful undersampling needs careful selection of:
 - Signal Frequency
 - Signal Bandwidth
 - Bandpass Filter
 - Sampling Frequency

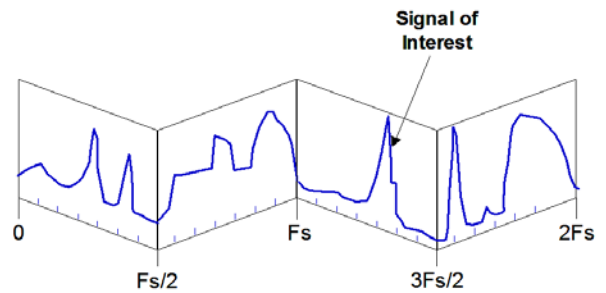

Figure 35

The third sampling mode, called undersampling or subsampling, is ideal for many systems that use an analog RF translator front end. These receivers usually deliver IF outputs, often at 21.4 or 70 MHz, with bandwidths ranging from a few kilohertz to tens of MHz—depending on the receiver.

If we wanted to perform baseband sampling on a 70 MHz signal, we would have to choose a sampling rate of well over 140 MHz. This may require an A/D that adds significant cost and power to the system.

However, because the IF signal is inherently bandlimited, we can take advantage of the folding caused by sampling and use a lower frequency A/D.

This is a little tricky since you have to carefully choose the sampling frequency and filtering according to the signal frequency and bandwidth.

Let’s see how.

Appendix A: High-Speed A/D Converters

Principles of Undersampling Design: Step 1

- Step 1: Design a bandpass filter or IF filter to pass the band of interest and reject all other signals to meet spurious and S/N requirements
- Tradeoffs
 - Sharper filter adds complexity, expense, calibration, space, etc.
 - Sharper filter allows lower A/D sample rate

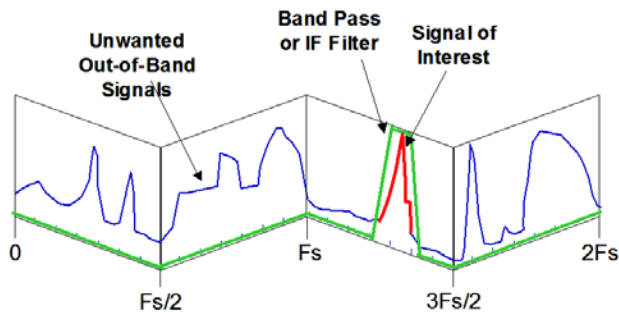

Figure 36

The fan-fold paper really comes in handy here.

First, design a bandpass filter that rejects unwanted signals and noise.

This is often fully satisfied by the standard IF filter in the RF translator, but you do have to check this.

Sharper filters add cost and maintenance but they do let you get away with a lower sampling rate as we'll see in the next figure.

Second (top of next column), choose a sampling frequency so that the passband of the filter, along with its skirts, falls entirely on a single page of fan fold paper.

There are many possible solutions to each case, so you have to pick the one that works best. You may have to go back and forth a few times to readjust the filter and sampling rate to get the best scheme.

Principles of Undersampling Design: Step 2

- Step 2: Choose a sampling frequency so that the filter pass band and skirts fall entirely within one page of the fan-fold paper
- Tradeoffs
 - Higher sampling rate allows broader bandwidth & simpler filter
 - A/D's with lower sampling rates are more accurate & less expensive

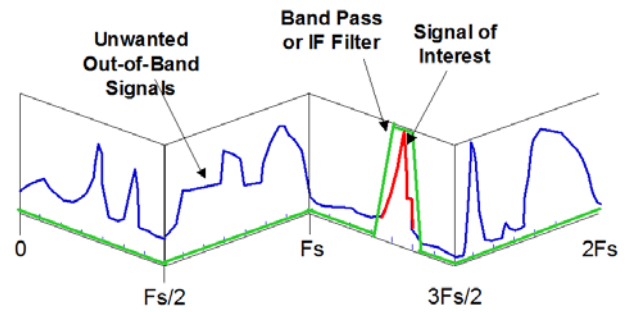

Figure 37

Here are some tradeoffs to consider:

With a higher sampling rate, the pages are wider and the filter becomes less complex. Also, there is a lower noise density folded into the 0 to $F_s/2$ band after sampling.

At higher sampling rates, however, the A/D is more expensive and the number of bits of accuracy drops off.

You also need to be sure that the A/D has a good wideband input stage to handle the IF signal with minimum distortion.

Equally important is the aperture uncertainty or phase jitter of the sample-and-hold amplifier, which is usually part of the A/D.

To make this job easier, many A/D converters are now specifically characterized to operate in undersampling applications.

Appendix A: High-Speed A/D Converters

Undersampling Performs Frequency Translation

- Signal of interest folds into the 0 to $F_s/2$ region
- Undersampling performs an automatic frequency translation
- Translated image may be reversed in frequency depending on which side of the “fold” the input falls

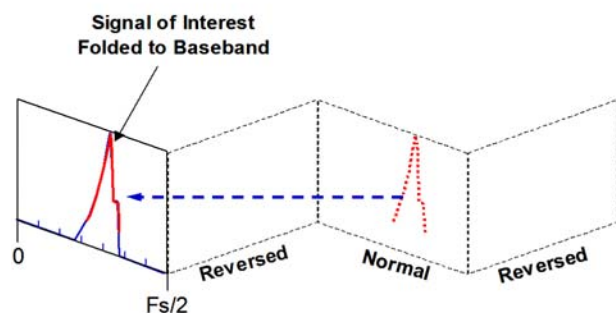

Figure 38

The effect of undersampling, as you probably expected by now, is that the IF signal is folded down to the first page. This is really an automatic frequency translation, performed for free by the sampling process.

For the signals on every odd numbered sheet, the effect is a frequency translation by a multiple of F_s . For the signals on even numbered sheets, there is a reversal of the frequency axis on that sheet, followed by a translation by an odd multiple of $F_s/2$. Again, this is much easier to follow by visualizing the fan-fold model.

This undersampling technique is extremely popular in software radio systems which almost always follow the A/D converter with a DDC (digital downconverter).

Regardless of where the undersampling folding process translated the signal of interest, the DDC can translate it down to 0 Hz as a complex baseband signal. Once the complex signal is at baseband, the reversal of the frequency axis is easily undone by simply changing the sign of the Q component.

Guidelines for Sampling and Undersampling

- Use the fan fold paper to validate your sampling plan for the characteristics of your input signal
- Carefully evaluate A/D specifications for operation in the undersampling mode
- Ensure low-noise, wideband circuitry in the front end ahead of the A/D
- Transforming coupling often is superior to an amplifier for IF or RF input signals
- Eliminate as many out-of-band signals and noise as possible, since they will fold
- Ensure the the sample clock is clean with low phase noise and jitter

Figure 39

There are usually several different sample clock frequencies that will work for undersampling. While the fan-fold paper model can show all of the correct frequency plans, the best choice will usually be determined by several other important practical considerations shown above.

Some A/D converters are specifically characterized for undersampling applications, while others are designed only for baseband sampling. Make sure to verify the specifications.

Noise and distortion of the input signal must be minimized so these components don't fold into the sampled signal. Special care must be taken to preserve the purity of the sample clock signal.

Undersampling can be an extremely valuable tool for software radio applications, since it can eliminate at least one additional stage of analog frequency translation and simplify system design.

Undersampling allows you to use an A/D converter with a lower sampling rate, which usually means more bits of resolution and better dynamic range. This lower sample rate also reduces the cost and complexity of the next stage of digital signal processing, recording, storage, or transmission.

Appendix B: Switched Serial Fabrics

Switched Serial Gigabit Interfaces - Why?

- Too many different I/O technologies per system
 - FPDP, PCI, VME, Ethernet, RS-232, FibreChannel, SCSI, PMC, IP, 1553, LVDS, ATM, etc.
- Bus backplanes are major data bottlenecks
 - All boards must share a common bus, one at a time!
- Parallel switched fabrics are expensive
 - RACEway was controlled by one vendor
- Cabling increases system cost and complicates maintenance
 - Cables and connectors can be a major factor in MTBF
- Software upgrades are difficult for specialized interfaces
 - Performance goals require software tuning of signal paths
- Need a better solution for moving data !
 - Fast, flexible, open, and inexpensive



Figure 40

The VMEbus still serves as the dominant bus structure for high-performance real-time embedded systems. As requirements grew following its introduction, VME acquired new interfaces such as VSB, RACEway, RACE++, VME64 et al. that provided improved performance.

All these different I/O technologies caused new problems with backplanes creating data bottlenecks and interfaces controlled by one vendor. System costs increased due to cabling, maintenance and software upgrades. A better solution for moving data was needed and it had to be fast, flexible, and inexpensive.

The answer turned out to be Switched Serial Gigabit Interfaces.

High-Speed Switched Serial Interfaces

- Gigabit serial links send data over a pair of wires using differential signaling
- Sequential 1s and 0s are sent over the pair of wires at a fixed bit rate
 - Popular serial rates: 10 MHz, 100 MHz, 1 GHz, 2.5 GHz, 3.125 GHz, etc.
- The clock, data, and data word framing are encoded into the serial bits stream, typically using 8B10B coding:
 - 10 bits of serial transmission are required to deliver 8 bits of data
 - Extra 2 bits maintain synchronization, framing and DC line balance
- SERDES - Serializer / Deserializer
 - Serializer: Encodes clock, frame, and 8 bits of data into a 10-bit stream
 - Deserializer: Decodes clock, frame and 8 bits of data from a 10-bit stream
 - Usually combined into one device for full duplex operation

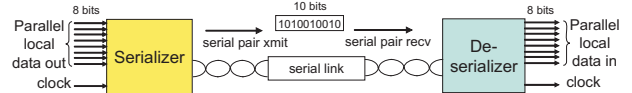

Figure 41

A switched serial fabric system connects devices together to support multiple simultaneous data transfers, usually implemented with a crossbar switch. Using differential signaling, data is sent over a pair of wires at a fixed bit rate such as 100 MHz, 1 GHz, 2.5 GHz, 3.125 GHz, etc.

The clock, data, and data word framing are encoded into the serial stream, usually with 8B10B coding. Ten bits of serial transmission deliver eight bits of data. The extra two bits maintain synchronization, framing and DC line balance.

The Serializer shown in Figure 17 encodes clock, frame, and eight bits of data into a 10-bit stream. The Deserializer decodes the 10-bit stream into clock, frame, and eight bits of data. These two functions are usually combined into one device for full duplex operation, known as the SERDES (SERializer/DESerializer).

Appendix B: Switched Serial Fabrics

Gigabit Serial Data Rates

▪ Gigabit Serial Data Transfer Rates Depend On:

- Serial clock frequency (serial bit rate)
- Number of bit “lanes” ganged together (e.g., 4X = 4 bit lanes)
- Physical layer encoding overhead (8B10B): 80% Efficiency
- Peak Rate (MB/sec) = (Serial Rate x Lanes x 80%) ÷ (8 bits per byte)
= (Serial Rate x Lanes) ÷ 10

| Peak Rates for Specified Number of Bit Lanes | | | | |
|--|------------|-------------|------------|------------|
| Bit Clock | 1X | 4X | 8X | 16X |
| 1 GHz | 100 MB/sec | 400 MB/sec | 800 MB/sec | 1.6 GB/sec |
| 2.5 GHz | 250 MB/sec | 1.0 GB/sec | 2.0 GB/sec | 4.0 GB/sec |
| 3.125 GHz | 312 MB/sec | 1.25 GB/sec | 2.5 GB/sec | 5.0 GB/sec |
| 5.0 GHz | 500 MB/sec | 2.0 GB/sec | 4.0 GB/sec | 8.0 GB/sec |

Figure 42

The raw speed of serial fabrics is governed by three factors:

The serial bit clock frequency; the inherent 8B10B channel encoding efficiency of 80%; and the number of lanes or parallel bit streams ganged together in the interface.

Since there are 8 bits per byte, the peak rate expressed in MB/sec becomes the serial rate expressed in GHz, times the number of lanes, divided by 10.

For example, for PCI Express with eight bit lanes or x8, the peak transfer rate in each direction is the serial bit clock of 2.5 GHz * 8 lanes / 10 = 2.0 GB/sec.

The table above shows the transfer rates for each lane width with 1, 2.5, 3.125, and 5.0 GHz bit clocks.

Of course, there is some additional overhead in the packet protocols, some of which are presented next.

Popular Gigabit Serial Protocols





- Xilinx Aurora
 - Low-level Link-layer protocol, with optional framing
 - Point-to-point links, primarily for raw data
 - Interfaces on Virtex-II Pro, Virtex-4 and Virtex-5 FPGAs
 - www.xilinx.com/aurora
- VITA 49 – Digital IF Protocol (VRT)
 - Built on top of Aurora link layer protocol
 - Point-to-point links, primarily for digitized IF signals
 - Packet headers include signal descriptors
 - www.digitalif.org
- PCI Express
 - Memory-Mapped Fabric
 - Personal computer connectivity, replacing PCI bus
 - Board-to-board and peripheral support
 - www.intel.com/technology/pciexpress
- Serial RapidIO
 - Packet Switched Fabric
 - Targeted for COTS and embedded multi-computing
 - Chip-to-chip, board-to-board, and peer-to-peer
 - www.rapidio.org

Figure 43

Xilinx offers a simple link layer protocol IP core engine called Aurora that interfaces with the RocketIO gigabit serial physical layer interfaces available in the Virtex-II Pro family.

Altera supports its Stratix GX Multi-Gigabit Transceivers with the SerialLite link layer protocol as well as full implementations of switched fabric IP cores.

The nice thing about this strategy is that you can design and build FPGA-based hardware products that adapt to different fabrics, depending on the protocol IP core you install.

VITA 49 is a radio transport protocol for SDR (Software Defined Radio) architectures that enables interoperability between diverse SDR components from different vendors

PCI Express is Intel’s initiative for connectivity between processors and boards in personal computers and workstations. It’s been used extensively to improve performance of graphics boards in Windows computers.

RapidIO is a packet-switched fabric targeted for embedded computer component vendors and system integrators. It addresses the needs of real-time computing at several levels.

Appendix B: Switched Serial Fabrics

PCI Express Interface

Introduced by Intel in 2004, PCI Express is a bidirectional serial link capable of high-bandwidth data transfers. Designed to replace the more limited PCI expansion bus, PCI Express supports enhanced features such as power management, hot-swappable devices, and has the ability to handle both host-directed and peer-to-peer data transfers. PCI Express can also emulate network environments by sending data between two points without routing it back and forth through the host chip.

Enabling greater bandwidth and performance, PCI Express helps simplify board design and is scalable for future increases in processor speeds and advances in high-performance computing and embedded systems.

Upgraded in 2007, PCI Express 2.0 doubled the data transfer rate over its predecessor for a transfer rate of up to 16 gigabytes per second for a x32 PCIe channel. Providing backwards compatibility with version 1.0, PCI Express 2.0 provides scalable performance, higher bandwidth, lower overhead and lower latency data transfers. The commercial PC motherboard roadmap includes transitions to PCI Express 3.0 capable of doubling the data rates of PCI Express 2.0.

Conceptually, the PCIe bus can be thought of as a 'high-speed serial replacement' of the older parallel PCI/PCI-X bus. At the software level, PCIe preserves compatibility with PCI: a PCIe device can be configured and used in legacy applications and operating systems which have no direct knowledge of PCIe's newer features. In terms of bus protocol, PCIe communication utilizes point-to-point switched serial links.

If you bought a desktop PC with Windows OS in the last few of years, it most likely came with a PCIe graphics card.

This development led to the rapid acceptance of PCIe at the consumer level, as the only bus that could accommodate increasingly faster graphics speeds. The high-bandwidth PCIe interface and fast dedicated graphics board memory made the better PC graphics possible.



Inside a PCI Express PC



Figure 44

Looking inside a desktop PCIe PC we see the familiar motherboard, part of which is shown in the above photograph. At the top of the photo, we see the two familiar PCI connectors where you'd find most of the legacy PCI expansion cards, such as 100BaseT Ethernet or sound.

Next to these PCI connectors are two small x1 PCIe connectors and at the bottom of the photograph we see a PCIe x16 connector. This is where the video card would plug in.

A PCIe card will fit into a slot of its physical size or bigger. It will not fit into a smaller PCIe slot. Some slots use open-ended sockets to permit physically longer cards and will negotiate the best available electrical connection. The number of lanes actually connected to a slot may also be less than the number supported by the physical slot size. An example is an x8 slot that actually only runs at x1; these slots will allow any x1, x2, x4 or x8 card to be used, though only running at the x1 speed. The advantage gained is that a larger range of PCIe cards can still be used without requiring the motherboard hardware to support the full transfer rate, thereby keeping design and implementation costs down.

Appendix B: Switched Serial Fabrics

SATA Computer Bus Interface

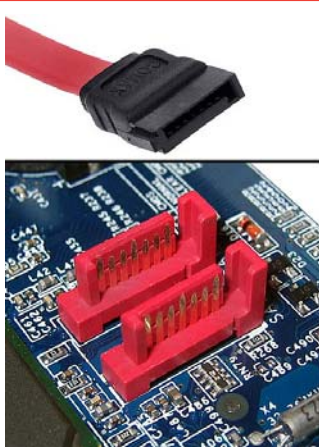

Figure 45
(Courtesy of Wikipedia)

Serial ATA (SATA or Serial Advanced Technology Attachment) is a computer bus interface for connecting host bus adapters to mass storage devices such as hard disk or optical drives. Serial ATA was designed to replace the older ATA standard (also known as EIDE), offering several advantages over the older parallel ATA interface: reduced cable-bulk and cost (7 conductors versus 40), native hot swapping, faster data transfer through higher signalling rates, and more efficient transfer through an optional I/O queuing protocol.

SATA host-adapters and devices communicate via a high-speed serial cable over two pairs of conductors. In contrast, parallel ATA (the redesignation for the legacy ATA specifications) used a 16-bit wide data bus with many additional support and control signals, all operating at much lower frequency. To ensure backward compatibility with legacy ATA software and applications, SATA uses the same basic ATA command-set as legacy ATA devices.

As of 2010, SATA has replaced parallel ATA in most shipping consumer desktop and laptop computers, and is expected to eventually replace it in embedded applications where space and cost are important factors.

Links



The following links provide you with additional information about the Pentek products presented in this handbook: just click on the model number. Links are also provided to other handbooks or catalogs that may be of interest to you in your development projects.

| Model | Description | Page |
|--|---|------|
| RTS 2701 | 2-Channel RF/IF 125 MS/sec Rack-mount Recorder | 14 |
| RTS 2706 | 8-Channel RF/IF 200 MS/sec Rack-mount Recorder | 15 |
| RTS 2715 | 2-Channel 10 Gigabit Ethernet Rack-mount Recorder | 16 |
| RTS 2721 | 2-Channel RF/IF 125 MS/sec Portable Recorder | 17 |
| RTR 2726 | 4-Channel RF/IF 200 MS/sec Rugged Portable Recorder | 18 |
| RTR 2746 | 8-Channel RF/IF 200 MS/sec Rugged Rack-mount Recorder | 19 |
| RTR 2755 | 2-Channel 10 Gigabit Ethernet Rugged Rack-mount Recorder | 20 |
| Handbooks, Catalogs and Presentations | | |
| Click here | Software Defined Radio Handbook | |
| Click here | Putting FPGAs to Work in Software Radio Systems Handbook | |
| Click here | Critical Techniques for High-Speed A/Ds in Real-Time Systems Handbook | |
| Click here | High-Speed Switched Serial Fabrics Improve System Design Handbook | |
| Click here | Cobalt Virtex-6 Product Catalog | |
| Click here | Pentek Product Catalog | |
| Click here | Pentek SystemFlow Recording Software Presentation | |